

# SAMUEL HEATH

**Product Number:** V133-AIS

**Description:** 3/4" Concealed thermostatic valve - rough



## Standards



## Flow rates

Gallons/Min	1.5 PSI	7.3 PSI	14.5 PSI	29.0 PSI	43.5 PSI	58.0 PSI	72.5 PSI
1/2" Feed		3.1	4.5	7.0	8.3	9.4	10.4
3/4" Feed		3.1	4.5	7.0	8.3	9.4	10.4

Flow rate data provided is indicative of each product and is given in open outlet conditions. Installation design, external connections and fittings not supplied may affect the data provided.

## Specification Drawing

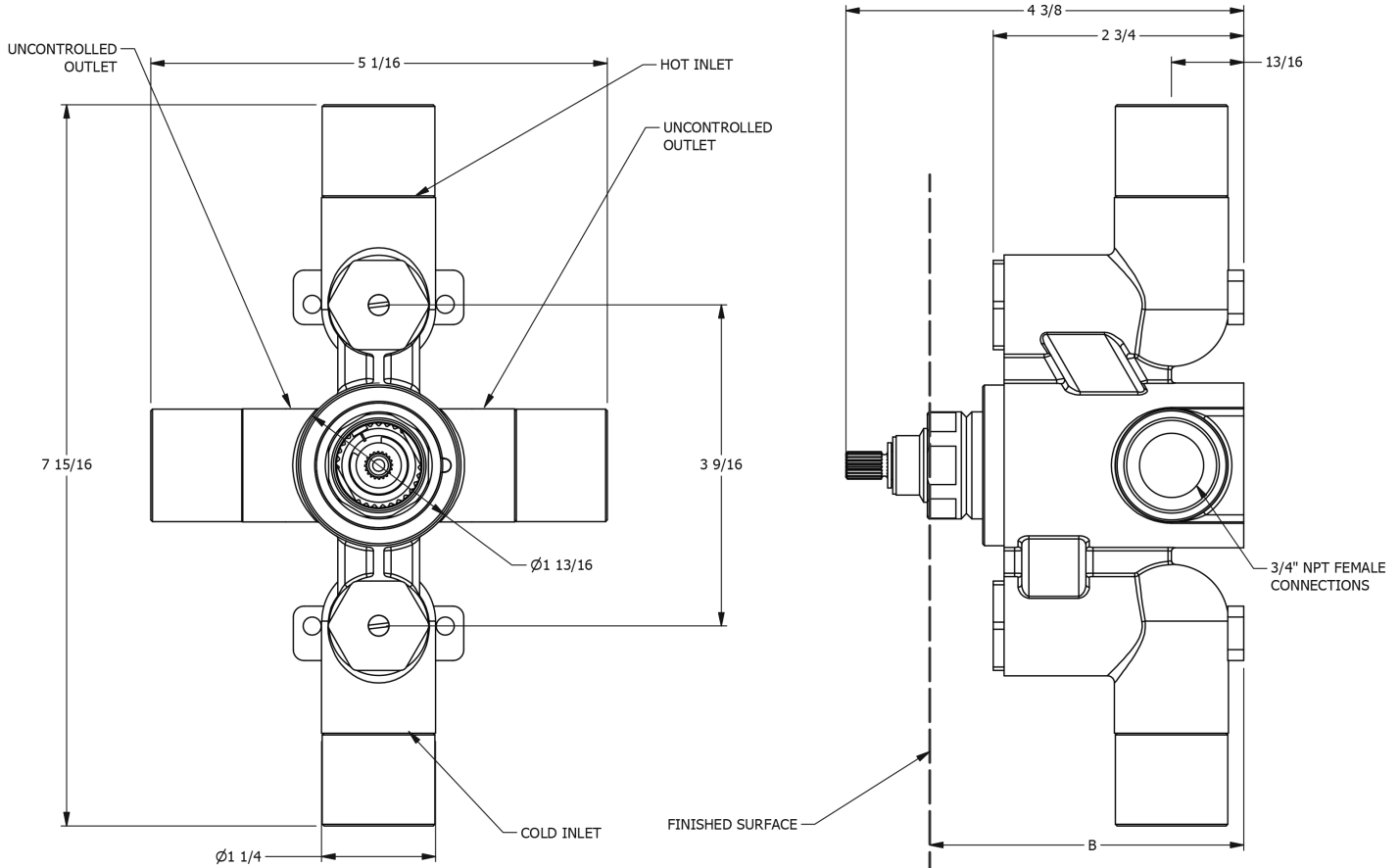

TRIM	DIMENSION B RANGE
V100-T	2 15/16" TO 4 9/16"
V200-T	2 15/16" TO 3 5/16"
V600-T	2 15/16" TO 3 1/4"
V700-T	4 1/4" TO 4 7/16"
V800-T	3 3/8" TO 3 5/16"

**UK Customer Service**  
 Leopold Street  
 Birmingham  
 B12 0UJ  
 Tel: +44 121 766 4200  
 Email: info@samuel-heath.com

**US Customer Service**  
 Federal I.D. No. 58-1504682  
 Email: usa@samuel-heath.com

**Specification Enquiries**  
 Design Centre Chelsea Harbour  
 1st Floor, North Dome, London  
 SW10 0XE  
 Tel: 020 7352 0249  
 Email: showroom@samuel-heath.com