

fluid

Innovative fixtures for life

SPECIFICATIONS

Customer Service: 1-800-460-7019
www.fluidfaucets.com

SSITM
SUSTAINABLE
SOLUTIONS
INTERNATIONAL

Specifications

- High quality fluid sinks are formed of #18 gauge (1.2mm) type 304 (18-8) nickel-bearing stainless steel.
- Overall dimension: 33"(838mm) x 21"(533mm) x 10"(254mm)
- Minimum cabinet size: 33" (838mm)
- Has 3-1/2" (90mm) diameter drain opening.
- Full undercoating and large rubber pads for noise reduction and condensation elimination.
- The exposed surfaces are polished to a satin finish.
- Stainless steel strainer is included.
- The sink is individually packed.

Codes and Standards

- ANSI/ASME A112.19.3-2000
- CSA B45 Series-02
- IAPMO / cUPC Listed

Warranty

- Limited Lifetime Sink Warranty against material and manufacturing defects for residential use.
- 1 Year Limited Warranty on all industrial, commercial and business applications.

fluid Point 90 Deg Angle Sink Single Bowl with Apron Kitchen Sink Model: ASA3321

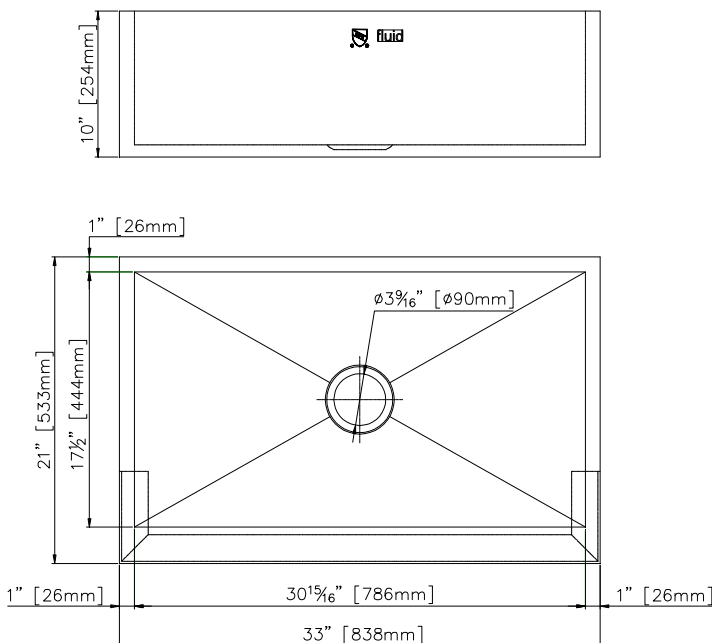

Optional Accessories such as colander, bottom grid and cutting board may be available. Please contact our sales representative for details.