

Carrington 6638CF

Formerly Serenity 13

66 x 38 x 26 inches

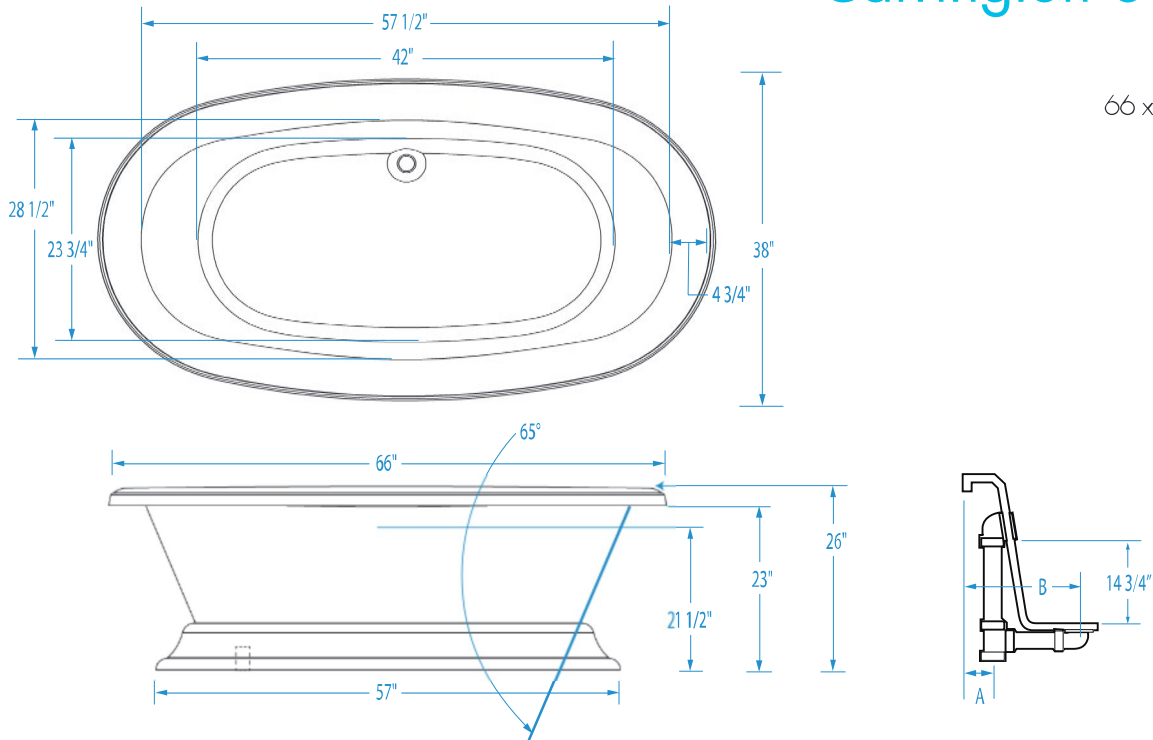

FEATURES Dimensional Tolerance $\pm 3/8"$. Dimensions needed for site preparation should be measured from the unit. Manufacturer assumes no responsibility for preparatory work.

Type and Model #	Material	System	Powered By	Heater	Controls	Drain	Pkg. Wt. lbs
Soaker #WV13AIR6638FTO	Cast Acrylic	-	-	-	-	Center Front	309
Air Bath #WV13AIR6638F	Cast Acrylic	Air injection	Variable speed blower	Inline	Electronic	Center Front	339

DIMENSIONS inches

Width Inches	Depth Inches	Height Inches	Skirt Height
66	38	26	-

SUMP DATA inches

Capacity to Overflow gal	Min. Operating Capacity gal	WIDTH @ centerline		DEPTH @ centerline	
		Top	Bottom	Top	Bottom
61	-	57 1/2	42	28 1/2	23 3/4

PLUMBING DIMENSIONS inches

A	B	Drain Diameter / Clearance
3 1/2	11	2 / 7 1/4

ELECTRICAL DATA

Component	Specification	Requirement
Heated Blower (Air Bath)	10.5 AMP; 120V	15 AMP; 120V, separate circuit; Class A GFCI

NOTES:

- 1) Where applicable, utilize cutout templates packed with unit for deck cutouts.
- 2) 16 x 16 minimum access required at pump/blower location(s).

Each Serenity air bath is equipped with an air heating system to raise the temperature of the air entering the bath. This air temperature will be lower than the bathing temperature of the water, but will help reduce rapid decrease in water temperature. In addition, the air coming from the air jets will feel cool against the skin. This system does not heat the water.