

## SP WASHLET®+ SW Wall-Hung Toilet, 1.28 GPF & 0.9

### FEATURES

#### SP Bowl

- DYNAMAX TORNADO FLUSH® system, high efficiency (1.28GPF/0.9GPF)
- CEFIONTECT® ceramic glaze minimizes waste from sticking to porous ceramic surfaces
- Universal Height

#### WASHLET+ SW

- Auto Flush
- Touchless auto open/close lid
- EWATER+® auto-cleans wand and bowl after every use
- PREMIST® automatically mists the bowl before each use
- Gentle aerated, warm water, front and rear spray with adjustable pressure and oscillating pulsating features
- Adjustable variable temperature for spray and seat
- Automatic air deodorizer
- Multifunction remote control with personalized memory settings for up to 4 users
- Warm air dryer with five variable temperature settings
- Night light illuminates the side and the inside of the bowl

#### DuoFit In-Wall Tank

- Dual flushing system, high-efficiency (1.28 GPF/4.8 LPF & 0.9 GPF/3.4 LPF) Avg. flush 1.1 GPF
- Adjustable 15"-19" mounting height
- Saves up to 9" of floor space compared to standard floor-mounted toilet
- Supports up to 880lbs
- Commercial 2" x 6" or optional residential installation with 2" x 4" wall studs with waste outlet kit

### COMPONENTS

- **CT449CFGT60#01**  
SP Wall-Hung Toilet
- **SW4547AT60(N)**  
WASHLET+ SW
- **WT173MA**  
In-Wall Tank System (1.28 GPF/0.9 GPF)
- **YT920#MS**  
Matte Silver Basic Square Push Plate

#### Available Options

- **YT920 (#WH,#MS)**  
Basic Square Push Plate – (White Matte, Matte Silver)
- **YT930 (#WH,#MS)**  
Basic Round Push Plate – (White Matte, Matte Silver)
- **YT970 (#SS, #B, #W, #N)**  
Round Push Plate (Stainless Steel, Black, White, Nickel)
- **YT980 (#SS)**  
Square Push Plate (Stainless Steel)



**DYNAMAX  
TORNADO FLUSH**



**AUTO FLUSH**



**CEFIONTECT**



**SKIRTED DESIGN**



**UNIVERSAL HEIGHT**



**EWATER+**

### COLORS/FINISHES

- **#MS**  
Bowl and Washlet in #01 Cotton with YT920#MS Matte Silver Push Plate

### CODES/STANDARDS

- Meets and exceeds ASME A112.19.2/CSA B45.1
- Certifications: IAPMO(cUPC®), EPA WaterSense, State of Massachusetts, and others
- Code Compliance: UPC, IPC, NSPC, NPC Canada, and others
- Legislative Compliance: California AB715, California Green Building Code, City of Los Angeles Water Efficiency Ordinance, and others
- ADA compliant
- Complies with CA Prop 65 warning requirements



# CWT4494549CMFGNA

## SP WASHLET®+ SW Wall-Hung Toilet, 1.28 GPF & 0.9 GPF

### SPECIFICATIONS & INSTALLATION NOTES

	SW4549AT60
<b>Power Rating</b>	AC 120V-60Hz, 1282W
<b>Power Cord</b>	2.95 ft/120 cm Length 3 Wire / 4 Pin Plug Harness
<b>Water Feature (Flow Rates)</b>	Rear: 9.1-14.5 oz/min
	Front: 9.8-14.5 oz/min
	Soft Rear: 9.1-14.5 oz min
<b>Washing Spray Temp.</b>	Min: 86°F/30°C Max: 104°F/40°C
<b>Safety Device</b>	Thermal Fuse
<b>Air Dryer Temp.</b>	Min: About 95°F/35°C Max: About 140°F/60°C
<b>Dryer Air Capacity</b>	10.24 ft <sup>3</sup> /min
<b>Seat Warming Temp.</b>	Min: 82°F/28°C Max: 97°F/36°C
<b>Water Supply Pressure</b>	Min: 7.25 psi Max: 108.75 psi
<b>Ambient Temp.</b>	Min: 32°F/0°C Max: 104°F/40°C
<b>Warranty</b>	One Year Limited Warranty
<b>Shipping Weight</b>	20.3 lbs
<b>Shipping Dimensions</b>	26" L x 18" x 7-1/4" H

	CT449CFG60	WT173MA
<b>Water Use</b>	1.28 GPF & 0.9 GPF (4.8 LPF & 3.4 LPF)	1.28 GPF & 0.9 GPF (4.8 LPF & 3.4 LPF)
<b>Flush System</b>	DYNAMAX TORNADO FLUSH®	Dual-Max®
<b>Min. Water Pressure</b>	8 psi (static)	8 psi (static)
<b>Water Surface</b>	5-1/2" X 4-1/8"	
<b>Trap Diameter</b>	2-1/8"	
<b>Installation Height</b>	15" to 19"	15" to 19"
<b>Trap Seal</b>	2-1/8"	
<b>Warranty</b>	One Year Limited Warranty	One Year Limited Warranty
<b>Material</b>	Vitreous China	Various
<b>Shipping Weight</b>	76 lbs.	43 lbs

### DIMENSIONS

#### CT449CFG60

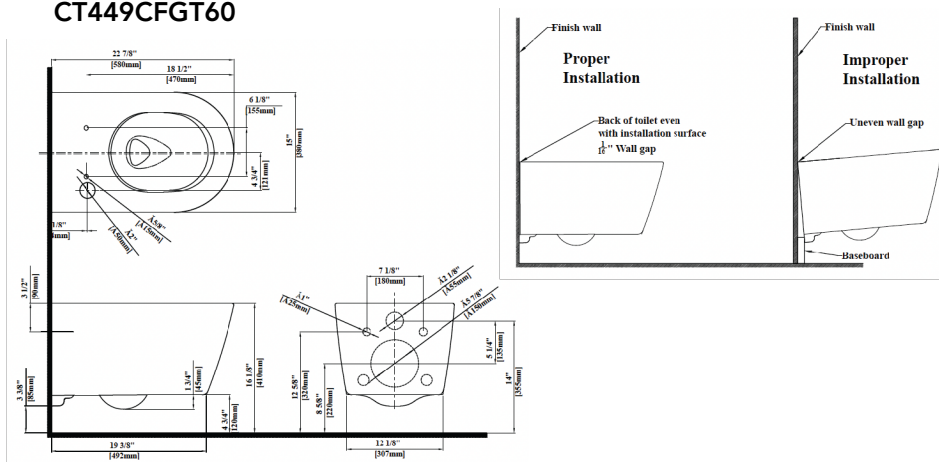

### CT449CFG60

- This universal height, high efficiency DYNAMAX TORNADO flushing system toilet shall be 1.28 GPF/ 0.9 GPF (4.8 LPF / 3.4 LPF). Toilet shall have CEFIONTECT® ceramic glaze. Toilet shall be mounted to in-wall tank system, elongated front bowl and wallmounted push-button type trip lever. Toilet shall be TOTO Model CT449CFG\_\_\_\_\_.

### SW WASHLET

- WASHLET SW may not fit certain toilet bowl designs
- If possible, with your order, please include your model number (from the underside of the tank lid)
- It is highly recommended to use a surge protector to prevent damage in the event of a power surge

### DuoFit In-Wall Tank

- Adequate structural bracing is required

# CWT4494549CMFGNA

## SP WASHLET®+ SW Wall-Hung Toilet, 1.28 GPF & 0.9 GPF

### DIMENSIONS

#### YT920

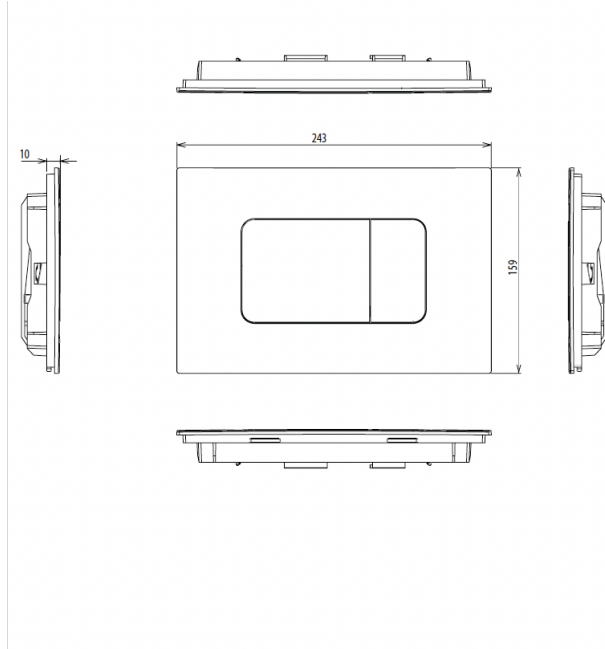

#### SW4549AT60

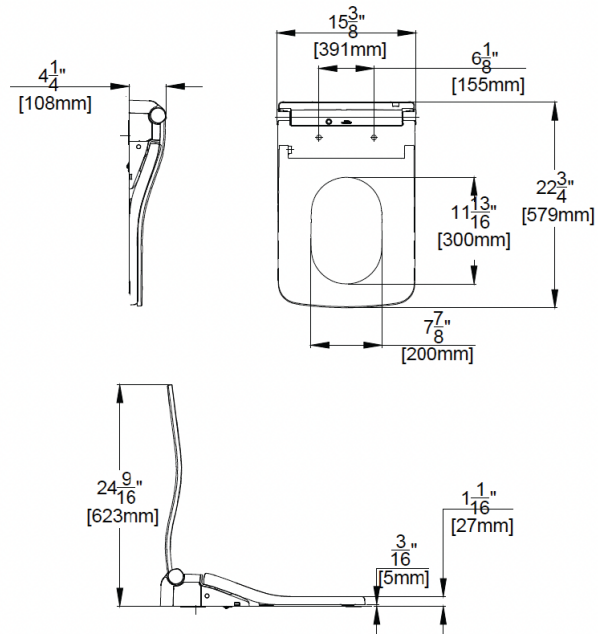

#### WT173MA

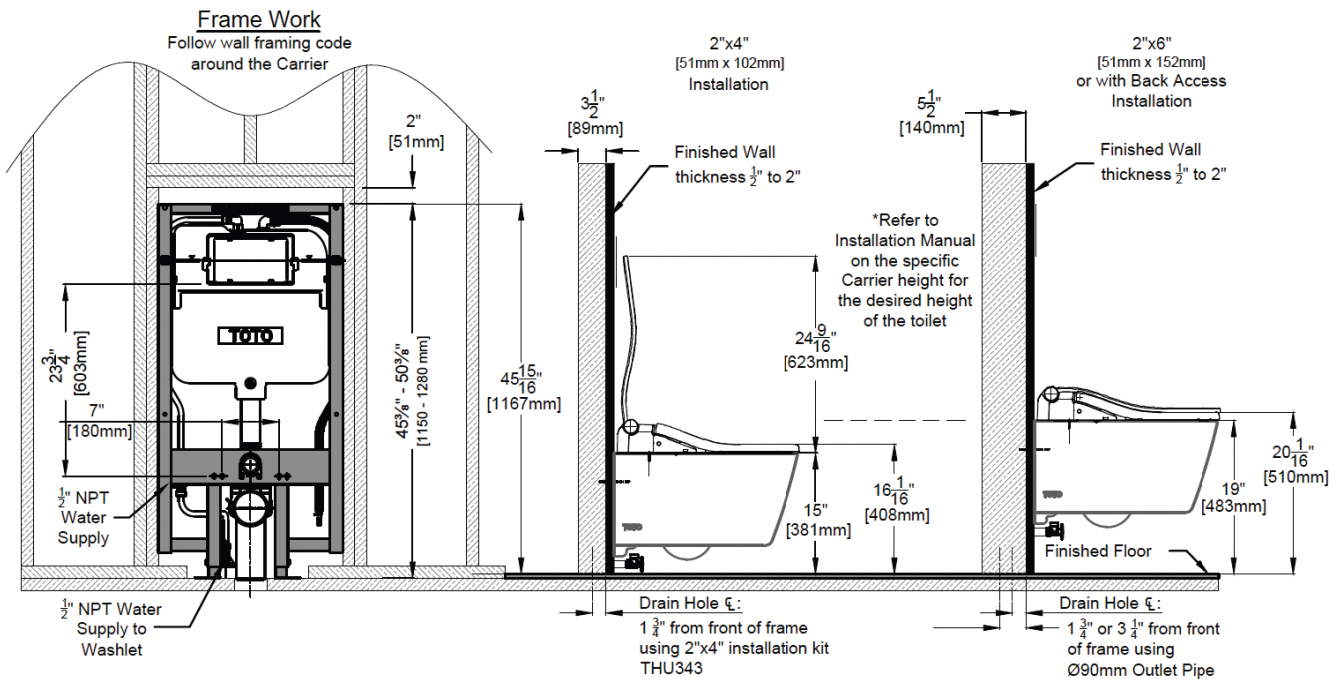

**TOTO®**

These dimensions and specifications are subject to change without notice