

# ATELIER MES-501SB



\*Flush-Mount Installation Kit is Required for Flush-Mount Installation

## • FEATURES

16 gauge type 304 stainless steel  
Tri-mount™ installation system

## • TECHNICAL INFORMATION

External dimensions: 12"L x 18"W x 8"D  
Basin dimensions: 9"L x 15"W x 8"D  
Frame width: 1-1/2"  
Frame thickness: 1/4"

## • FINISHES

Satin Brushed stainless steel (SB)

## • INSTALLATION OPTIONS

Flush-mount (MTK-101AL is required)  
Top-mount  
Under-mount

## • MINIMUM CABINET SIZE (I.D.)

Flush-mount 14"  
Top-mount 11"  
Under-mount 15"

## • INDUSTRY'S ONLY STAINLESS STEEL SINK DESIGNED SPECIFICALLY TO BE FLUSH-MOUNTED

## • US PATENT PENDING

### • Tri-mount Installation

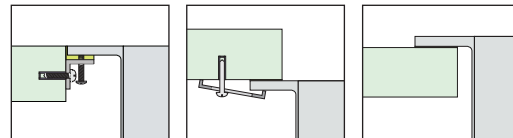

Flush-mount

Under-mount

Top-mount

## • ACCESSORY OPTIONS

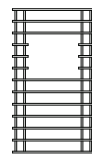

MBG-051SB  
Basin Grid

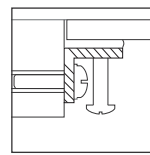

MTK-101AL  
Mounting Kit



MCB-501BB  
Cutting Board

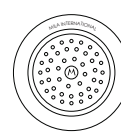

MKD-101SB  
Strainer

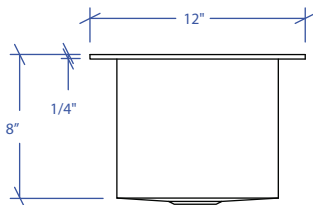
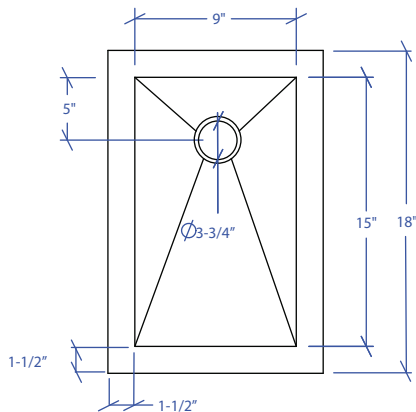

PROJECT INFORMATION			
Project			
Date	/ /	QTY	
Specifier			
Contact			
Note			

ENTERTAINMENT TRI-MOUNT™