

KARTELL LAUFEN

Washbasin, shelf left, with concealed outlet, w/o overflow - Always Open Drain, wall mounted



DIMENSIONS

Length	35 7/16 inch
Width	18 2/16 inch
Height	4 12/16 inch

COLOUR AND FINISH

000 White

OPTIONS

185 - three tapholes, US/CAN, 8 inches apart, without overflow slot

SPECIFICATION TEXT

Washbasin Console Kartell • LAUFEN
 Saphirkeramik (unique extra strong ceramic material)
 Meets or exceeds the following:
 ASME 112.19.2 cC/IAPMO listed
 Features:
 Rectangular basin, wall mounted
 Hidden outlet and overflow
 Limited 5 year warranty

MOUNTING ACCESSORIES INCLUDED

Valve pre-assembled
 pop up valve, part nr. 898302
 Mounting set M 6/16" x 5 8/16" (M10 x 140 mm), part nr. 899882
 Trap Thread Adapter G 1 1/4" / 1 1/2"-11.5NPT, part nr. 899338 (colour 004)

Asymmetric	Installation type : Vanity, Wall-hung	Shape : Rectangular
Bottom side glazed	Integrated shelf	Shelf position : Left
Bowl depth (mm) : 95	Internal Shape : Rectangular	Taphole configuration : 3 Tapholes
Bowl length (mm) : 580	Material : Saphirkeramik	Washbasin capacity (l) : 6.2
Bowl position : Right	Net weight (kg) : 23.1	Waste : Included
Bowl width (mm) : 315	Number of fixing points : 3	

TECHNICAL DRAWINGS

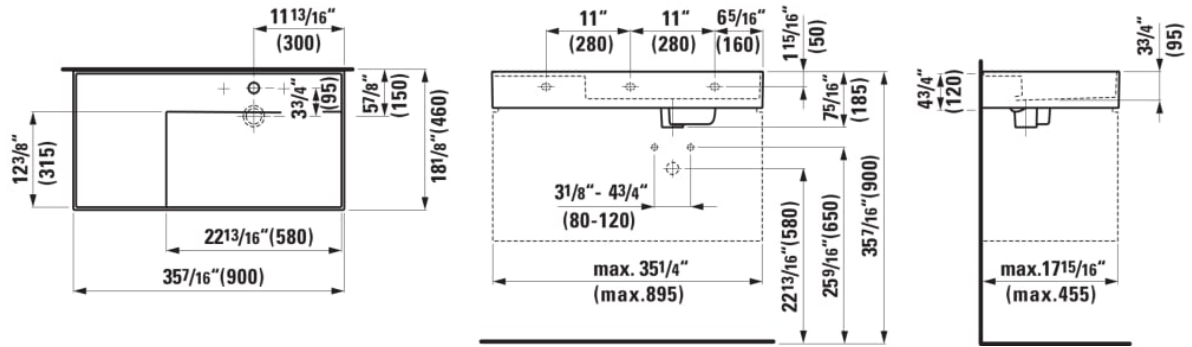

COMPATIBLE WITH



3-hole basin mixer,
projection 166 mm, swivel
spout, without pop-up
waste

H312333004220U



3-hole basin mixer,
projection 166 mm, swivel
spout, with pop-up waste

H312333004221U



Set of adjustable feet (2
pieces), anodized aluminum
surface

H4076200330041



Shelf for washbasin, plastic

H385331...0001



Kartell LAUFEN

A complete bathroom project inspired by the iconic design of Kartell together with the quality of Laufen. On one hand, Kartell, Italian, creative, colourful and iconic. The family company that has marked the history of design and revolutionised furnishing in the use of plastic materials for over 60 years now. On the other, Laufen, Swiss, rigorous and reliable. For 125 years, a great commitment to make culture in the bathroom and innovation in the production of ceramic sanitaryware. It is a shared project of great innovation, which has required more than three years to develop, the result of the constant research that is part of the DNA of the two companies. Serving as the link between these two players are the award winning designers Ludovica+Roberto Palomba, who themselves are leaders in designing for the bathroom.

