

**HALIFAX  
61" CAST IRON  
SLIPPER TUB**

Cat. No.  
CTSN61I



L: 61-1/4"  
W: 30-1/4"  
H: 21-1/2" - 31 (from floor to top of tub)  
15-1/2" - 23-3/4" (from bottom of tub to top of tub)

Water Depth: 16-1/8" at to top of tub  
Water depth: 14-3/8" to overflow  
Overflow hole: 1 1/2"

**The following is recommended for  
CTSN61I tubs:**

- Faucet: part #4602, 4604 or 7082
- Rigid, freestanding supplies: part #4502
- Leg tub drain: part #5599

Gallon Capacity: 45  
Shipping Weight: 465 lbs.  
Empty Weight: 285 lbs.  
Filled Weight: 661 lbs.

**Features:**

- ▶ Inside finish is white enamel
- ▶ Tub exterior is white (epoxy)
- ▶ No faucet holes
- ▶ Non-skid strips
- ▶ Pre-drilled overflow hole
- ▶ Cast Iron imperial feet available in 8 finishes
- ▶ Tub is thoroughly inspected before shipment

**Foot Finishes:**

- BL** Painted Black
- BQ** Painted Bisque
- PB** Polished Brass
- CP** Polished Chrome



- PN** Brushed Nickel
- BN** Brushed Nickel
- WH** Painted White
- ORB** Oil-Rubbed Bronze

**Custom Colors Available** (inside of tub is always white enamel):  
Painted bathtubs are considered "special order" and are not returnable  
\$160 Bisque or Black \$250 Designer Color

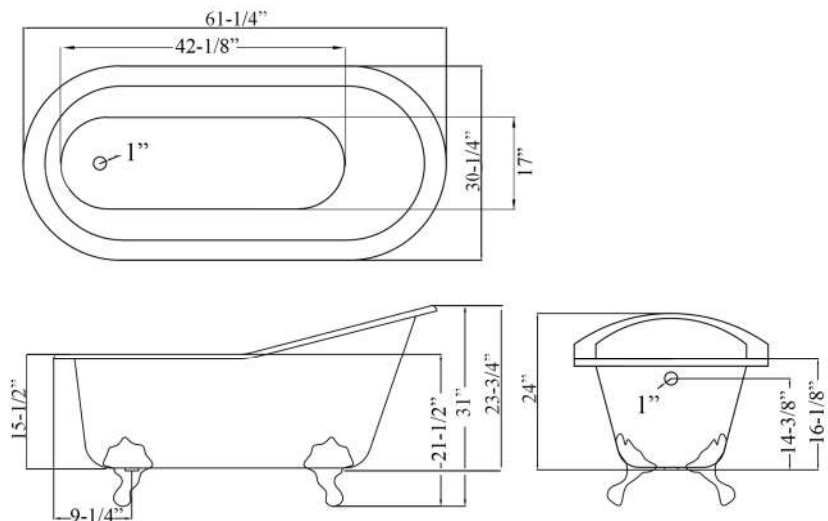

Dimensions of fixture are nominal and may vary within the range of tolerances established by ANSI Standard A112.19.2. Dimensions and specifications subject to change without notice.