

SINGLE MOUNTING DECK FEATURES

- In order to accommodate the installation of various fixtures and controls, Caribe may be ordered with a single mounting deck.
- This 12" x 6½" deck is positioned in the center of the water canal.
- It may be positioned on either the front or rear side of the tub.
- This provides a mounting surface for spout and hot and cold mixing valves, if they are not wall-mounted.
- If the spout and valves are wall-mounted, the deck would accommodate controls for the whirlpool and / or air bath.
- A deck is **required** for mounting the whirlpool controls.
- Deck does not interrupt the operation of the overflow function.
- If more mounting space is required, see reverse side for Caribe with Dual Decks.
- **Must be specified at the time of ordering.**

Caribe (Continued) with Optional Single Deck



Caribe shown above with single mounting deck.

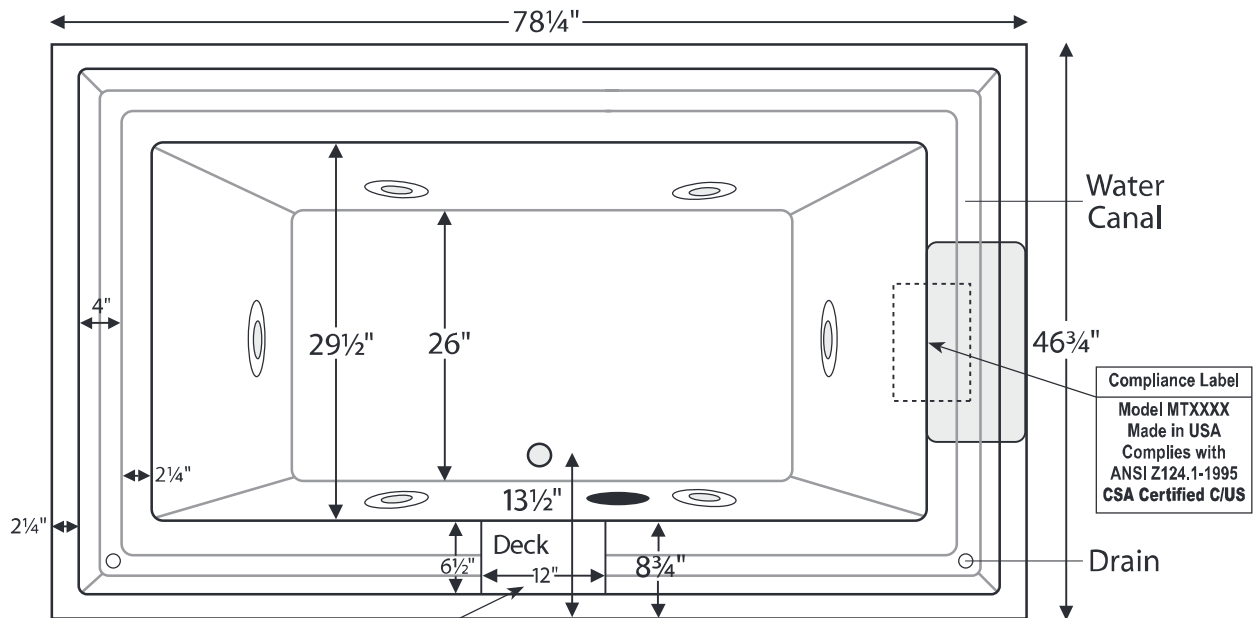

Solid raised deck provides a mounting area for fixtures and controls, such as Fill-Flush® or Breda backflow prevention valve.

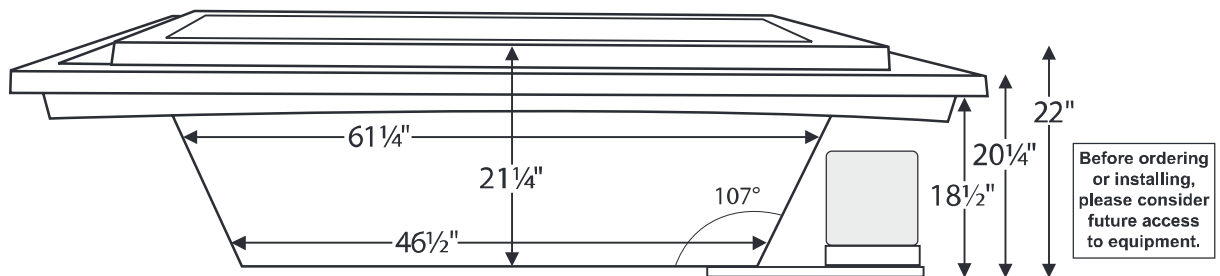

IMPORTANT: If you are planning to use a glass enclosure, MTI must be advised when ordering for possible relocation of controls.

