

Cayman 7

72" x 72" x 23.25"

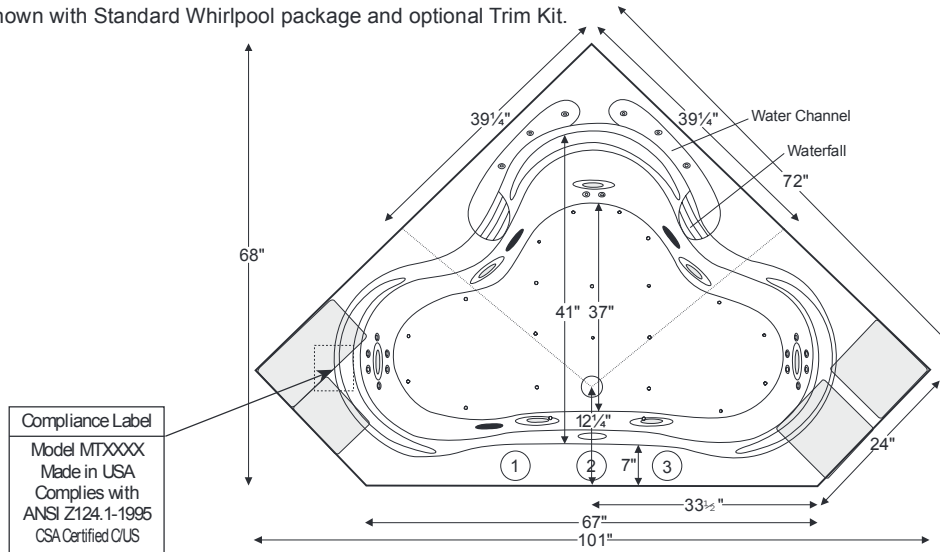

Shown with Standard Whirlpool package and optional Trim Kit.



Compliance Label
Model MTXXXX
Made in USA
Complies with
ANSI Z124.1-1995
CSA Certified CUS

Numbered areas on tub deck represent possible locations to install cleaning systems, faucets and other fixtures.

Shown with Air Massage and Ultra Whirlpool Package.

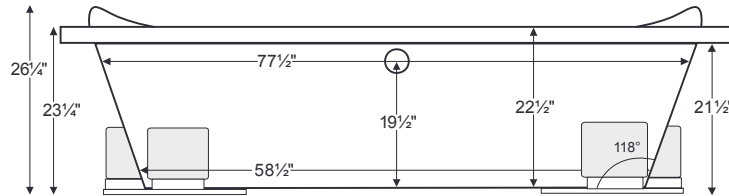

IMPORTANT:
Air baths and tubs with a pre-leveled foam base or frame system add 2-3" to overall tub height.

ELECTRICAL COMPONENTS & SPECIFICATIONS		
Required Electrical Service - 110 Volt		
Hydrotherapy Package	Components Included	GFCI
Soaker	recirculating waterfall pump	1-15 amp
Standard Whirlpool	2-bhp pump, recirculating waterfall pump	1-15 amp, 1-20 amp
Ultra Whirlpool	2 2-bhp pumps, inline heater, recirculating waterfall pump	2-20 amp
Air Massage	heated blower, recirculating waterfall pump	1-15 amp, 1-20 amp
Air Massage Elite	heated blower, chromatherapy, recirculating waterfall pump	1-15 amp, 1-20 amp
Air Massage with Standard Whirlpool	2-bhp pump, heated blower, recirculating waterfall pump	2-20 amp
Air Massage with Ultra Whirlpool	2 2-bhp pumps, inline heater, heated blower, recirculating waterfall pump	2-20 amp
Air Massage Elite with Standard Whirlpool	2-bhp pump, heated blower, chromatherapy, recirculating waterfall pump	2-20 amp
Air Massage Elite with Ultra Whirlpool	2 2-bhp pumps, inline heater, heated blower, chromatherapy, recirculating waterfall pump	2-20 amp
For electrical requirements of tub options, see page C-2. CSA Certified C/US; ANSI Z124.1 for plastic tubs and ANSI 112.19.7 for whirlpool components.		

IMPORTANT ORDERING & INSTALLATION INFORMATION:

- Before ordering or installing, please consider future access to equipment.
- Add bedding compound to fully level and support bottom of tub.
- Tubs equipped with an air bath or a pre-leveled foam base are designed to rest on the floor without bedding compound, provided the floor is level.
- Overall tub height is increased by approx. 2-3" when tub is equipped with any air bath package or when pre-leveled foam base or frame system is ordered.
- Please measure tub on-site before building tub decking.
- If you are planning to use a glass enclosure, MTI must be advised when ordering for possible relocation of controls.
- Suction and control locations may vary.
- Specifications and configurations are subject to change without notice.
- Measurements are $\pm 1/2"$ and are subject to change without notice.
- Measurements herein supersede all others published prior to publication date shown below.

See the "Designer Collection Tubs Installation & Operation Manual" included with tub delivery or go to mtibaths.com/support/installation_operation/manuals for all the information necessary to install and operate the tub.

MTI's Customer Service Department is available Monday-Friday 8am-6pm EST at 800-783-8827 or customerservice@mtibaths.com to answer any questions pertaining to ordering or installation.

