





Specification:

1. Finish: See Table
2. Hardware: See Table
3. Hinge: 700.0537.25+600.1234.05 ( 4 set )
4. Slide: USE58-300-18 + US-CLIP-4W ( 2 set )
5. Lid Stay ( 2 pcs )
6. The tolerance is +/- 1/8"

Item number	Finish	Deco Hardware	
		Item number	Qty
VN2WAV-48-GR-NT	Grey	242SN	4
VN2WAV-48-WH-NT	White	242MB	4
VN2WAV-48-BL-NT	Blue	242SBZ	4
VN2WAV-48-GN-NT	Green	242SBZ	4

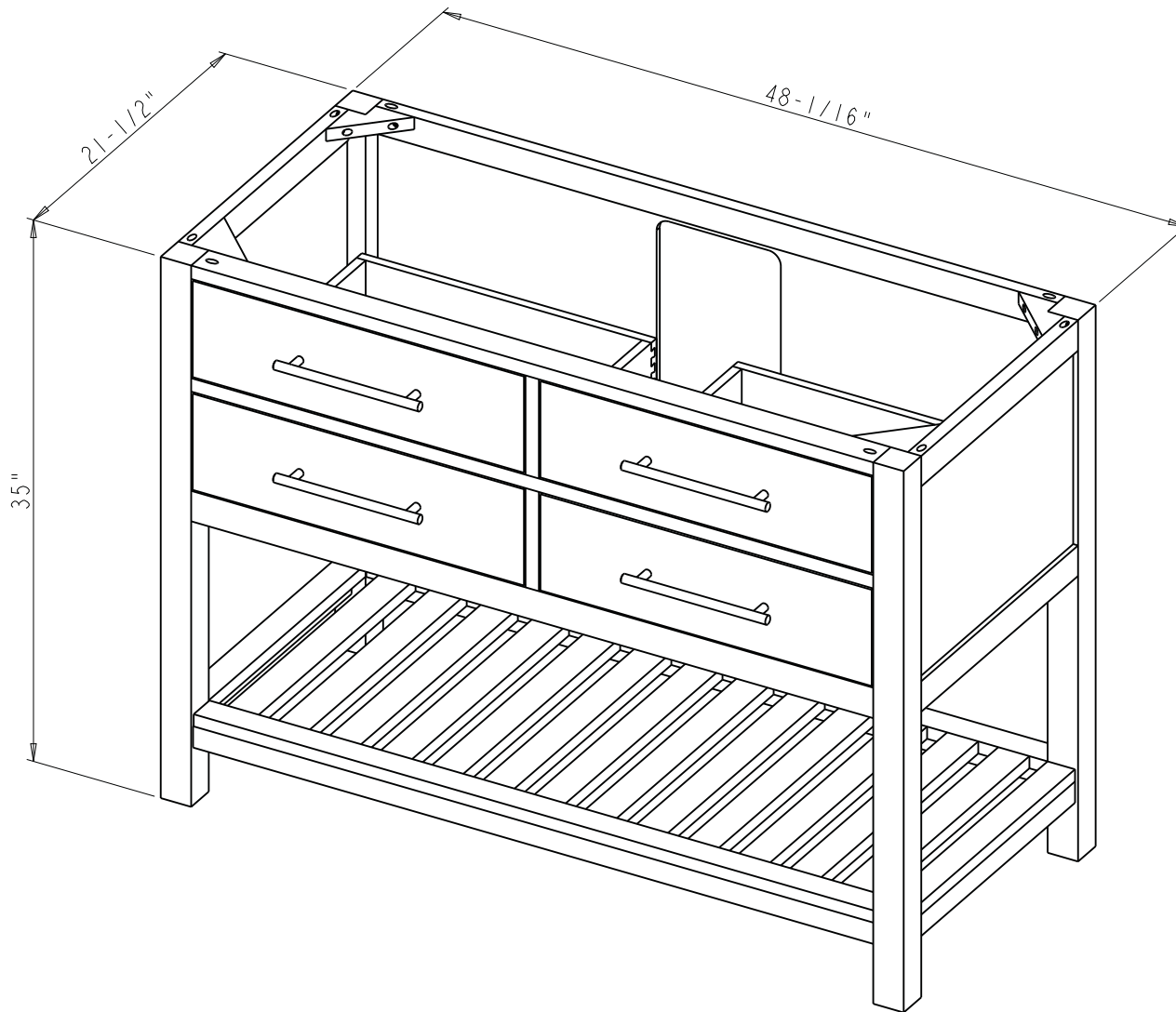
 <b>PROPRIETARY AND CONFIDENTIAL</b> THE INFORMATION CONTAINED IN THIS DRAWING IS THE SOLE PROPERTY OF HARDWARE RESOURCES INC. ANY REPRODUCTION IN PART OR AS A WHOLE WITHOUT THE WRITTEN PERMISSION OF HARDWARE RESOURCES INC. IS PROHIBITED.	ITEM#: VN2WAV-48	MATERIAL:	
	FINISH:	WEIGHT: 9	
	TOLERANCE UNLESS OTHERWISE SPECIFIED: X ±0.20 X.X ±0.10 X.XX ±0.05 ANGULAR: ±0.5°	UNITS: DRAWN BY: <b>Tony.Huang</b> APPROVED BY: DATE: Apr-15-21	PROJECTION 
	DO NOT SCALE DRAWING	RELEASE LEVEL:	REVISION:



	ITEM#: VN2WAV - 48		MATERIAL:	
	FINISH:		WEIGHT: 9	
<p><b>PROPRIETARY AND CONFIDENTIAL</b></p> <p>THE INFORMATION CONTAINED IN THIS DRAWING IS THE SOLE PROPERTY OF HARDWARE RESOURCES INC. ANY REPRODUCTION IN PART OR AS A WHOLE WITHOUT THE WRITTEN PERMISSION OF HARDWARE RESOURCES INC. IS PROHIBITED.</p>	PROJECTION 		DATE: Mar - 24 - 20	
	TOLERANCE UNLESS OTHERWISE SPECIFIED:	UNITS:	DRAWN BY: Hugo.cai	DATE:
	X ±0.20	SIZE:	APPROVED BY:	DATE:
	X.X ±0.10	SHEET:	RELEASE LEVEL:	REVISION:
X.XX ±0.05	DO NOT SCALE DRAWING			
ANGULAR: ±0.5°				

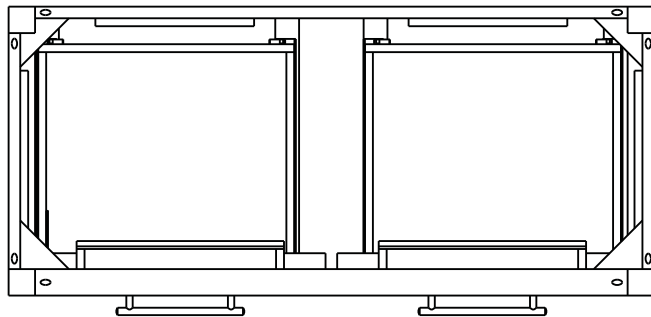
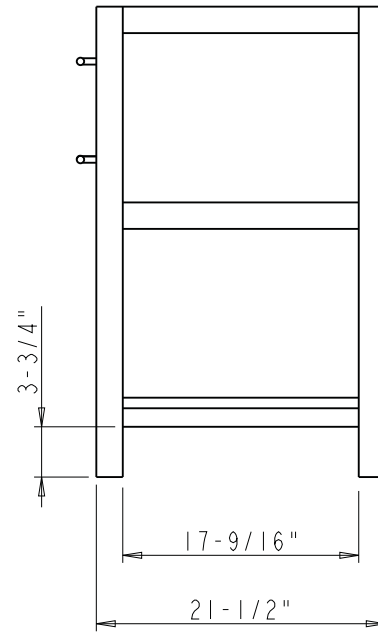
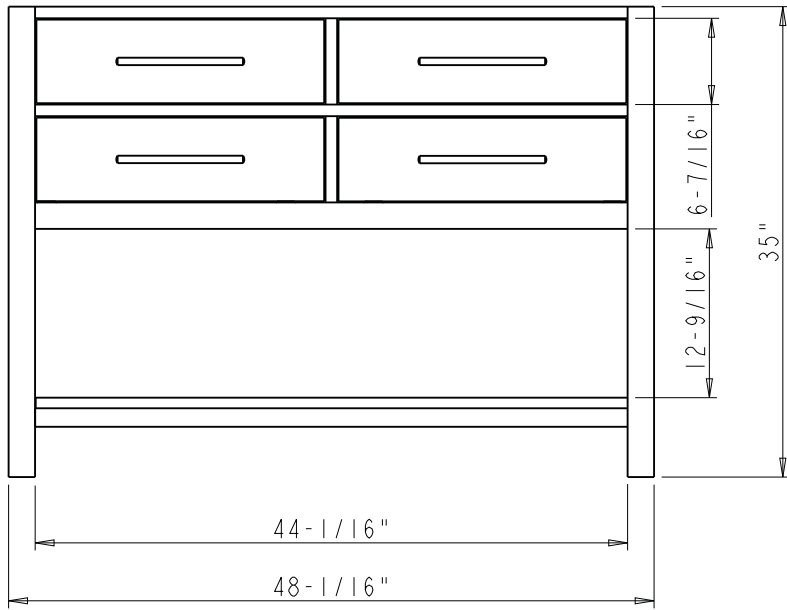

 <p><b>PROPRIETARY AND CONFIDENTIAL</b></p> <p>THE INFORMATION CONTAINED IN THIS DRAWING IS THE SOLE PROPERTY OF HARDWARE RESOURCES INC. ANY REPRODUCTION IN PART OR AS A WHOLE WITHOUT THE WRITTEN PERMISSION OF HARDWARE RESOURCES INC. IS PROHIBITED.</p>	ITEM: VN2WAV - 48		MATERIAL:		
	FINISH:		WEIGHT:		
	TOLERANCE UNLESS OTHERWISE SPECIFIED: X ±0.20 X.X ±0.10 X.XX ±0.05 ANGULAR: ±0.5°		UNITS:	DRAWN BY: <i>Hugo.cai</i>	DATE: Mar - 24 - 20
	DO NOT SCALE DRAWING		SIZE:	APPROVED BY:	DATE:
		SHEET:	RELEASE LEVEL:	REVISION:	

