

## Enville 4 Rail

39.0 x 22.0 x 6.38

06 April 2021

ENVI-4-E-990.6-558.8-xx

UB - UNLACQUERED BRASS	CP - POLISHED CHROME
BB - BRUSHED BRASS	NP - POLISHED NICKEL
BN - BRUSHED NICKEL	LB - LIGHT BRONZE
LAB - LIGHT ANTIQUE BRONZE	MB - MEDIUM BRONZE
MAB - MEDIUM ANTIQUE BRONZE	DB - DARK BRONZE
DAB - DARK ANTIQUE BRONZE	GP - GOLD PLATED
AG - ANTIQUE GOLD	GM - GUN METAL
MWP - MATT WHITE P.COAT	MBP - MATT BLACK P.COAT

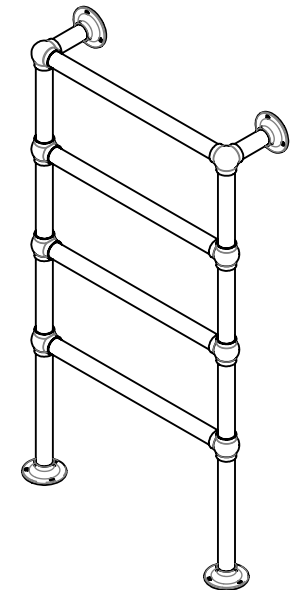
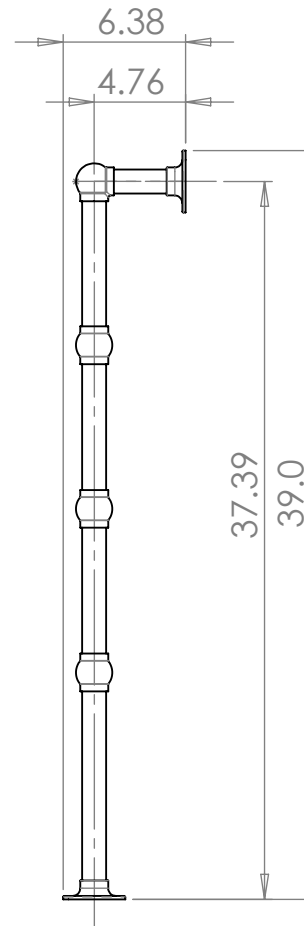
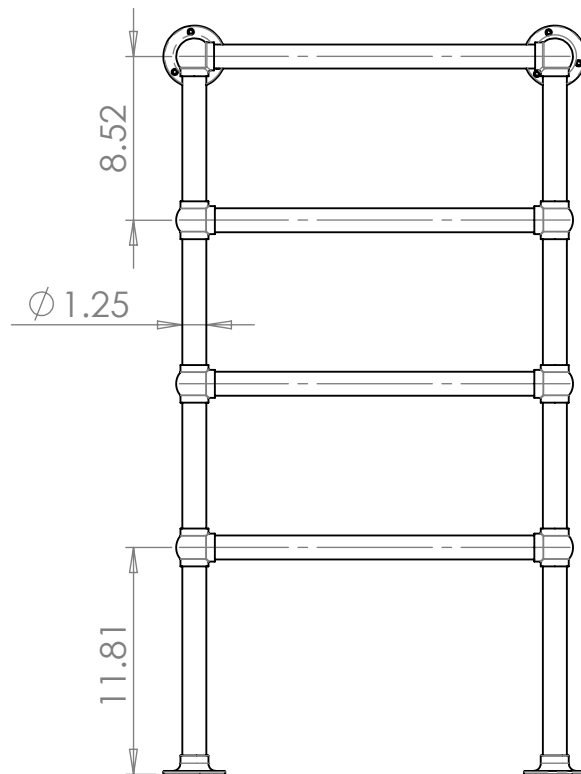
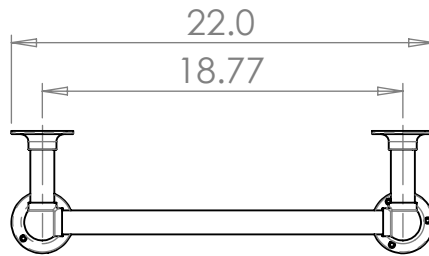

THE STERLINGHAM CO.

SCALE: 1:10 APPROX WEIGHT 6.51KG

MANUFACTURED FROM BRASS

Units 2 & 2A Stamford Street  
Amblecote, Stourbridge,  
Worcestershire  
England, DY8 4HR

Telephone : 01384 370901  
Fax : 01384 880159  
ussales@sterlingham.co.uk  
www.sterlingham.co.uk

### For Electric Towel Warmers:

Default cable exit is bottom right, 3m cable length - this can be modified, please state your requirements upon placing your order.



Handmade  
*in the heart of*  
BRITAIN