

VARIANT 19-³/₄" x 16-¹/₂" OVAL ABOVE COUNTER BASIN

Cat.No.
5-521WH



Faucet not included

W: 19-³/₄"
D: 16-¹/₂"
H: 5"

Features:

- ▶ Above counter basin
- ▶ Vitreous china for durability
- ▶ No overflow
- ▶ 1 faucet hole
- ▶ Drain not provided
- ▶ Can be used with grid drain #5601 or umbrella drain # UD701 (Not included)

Colors:
WH White

Compliance Certification
Meets or exceeds the following specifications: ASME A112.19.2 2018 and CSA B45.1-18 for ceramic plumbing fixtures.

***Please do NOT drill hole without actual product.**

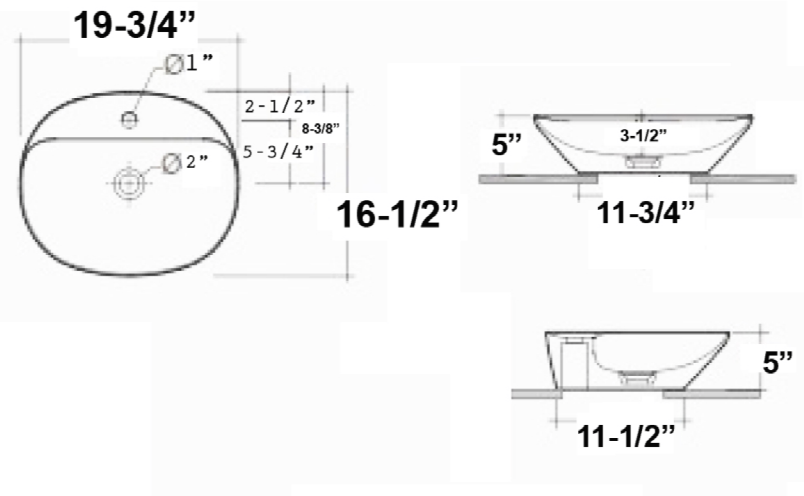

Interior Dimensions:

Basin Interior: 12-¹/₄" x 19"
Basin Depth: 3-¹/₂"
Back of basin to center of drain: 8-³/₈"

Dimensions of fixture are nominal and may vary within the range of tolerances established by AMSE Standard A112.19.2.2018 Dimensions and specifications subject to change without notice.