

In-Wall Vessel Lavatory Faucet Installation Instructions

CALIFORNIA FAUCETS RECOMMENDS THAT ALL PLUMBING PRODUCTS BE INSTALLED BY A LICENSED PROFESSIONAL

IMPORTANT: Read all instructions prior to installation and provide copy of instructions to consumer.

Operating Specifications:

Recommended Supply Pressure: 20 to 70 psi*†

Maximum Flow Rate: 1.2 gpm

* Operating pressures between hot and cold supplies should vary no more than 30 psi.

† If water pressure exceeds 70 psi, install a Pressure-Reducing Valve (PRV).

I INSTALLING SPOUT TO IN-WALL VALVE

NOTE: Recommended through-hole size shall be $\varnothing 1-1/4"$

- Prior to installing faucet trim in-wall vessel rough VALVE (1), **CF-VL-R**, must be properly installed and wall surface must be completely finished
- Apply thread sealant to both threaded ends of NIPPLE (2), not supplied, and tighten into center outlet of VALVE (1)
- Securely tighten QUICK CONNECT (3) onto end of NIPPLE (2) using $1/2"$ open end wrench
- Place O-RING (5) into spout ESCUTCHEON (4a)
- Slide SPOUT (4) onto QUICK CONNECT (3) and tighten SETSCREW (4b) on bottom side of SPOUT (4)

NOTE: Spout installation shown with lavatory vessel valve, Tub Spout installation is the same

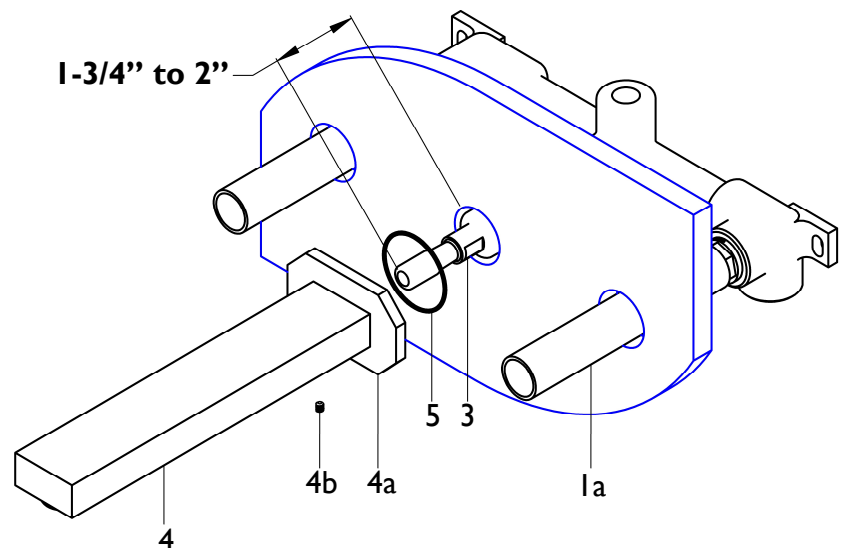
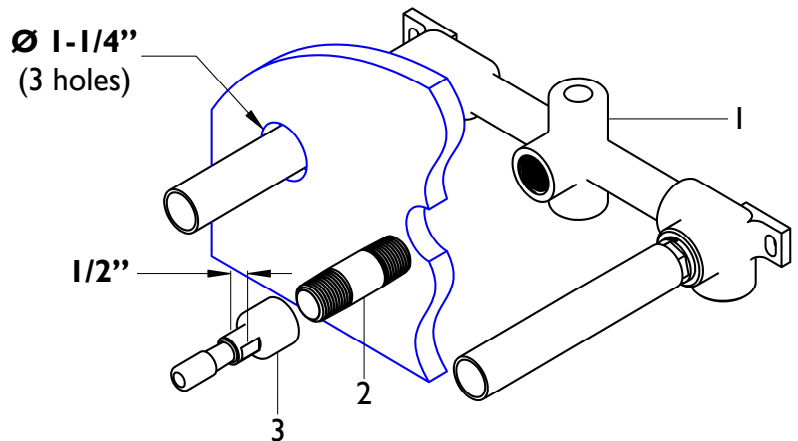

2 ALIGN & TRIM VALVE STEM

- Remove MUDGUARD (1a) from VALVE (1)
- To obtain proper HANDLE (6) alignment it may be necessary to re-align cartridge STEM (1b); to align STEM (1b), slightly loosen the cartridge NUT (1d), place HANDLE (6) on STEM (1b) and **TIGHTEN** in CW direction until desired alignment is achieved; retighten cartridge NUT (1d) to factory torque setting of 14 ft-lbs.

WARNING: Cartridge NUT (1d) **MUST** be properly torqued to prevent possible failure and/or water damage

- Using a marking device (e.g. pencil or marker) indicate a distance of 1/2" from finished wall on ALL-THREAD (1c); unscrew ALL-THREAD (1c) from valve STEM (1b)
- Cut STEM (1b) 1-1/8" from finished wall surface
- Cut off excess ALL-THREAD (1c) at indicated mark and reattach ALL-THREAD (1c) onto valve STEM (1b) – repeat on other side

IMPORTANT: To prevent HANDLE (6) rotation during operation of faucet set LOCK-NUT (1e) **MUST** be placed on both ALL-THREAD (1c) of VALVE (1)

- Place LOCK-NUT (1e) onto ALL-THREAD (1c). Use supplied SOCKET (1f) to hand-tighten LOCK-NUT (1e) against cartridge NUT (1d). Using 1" open end or adjustable wrench tighten LOCK-NUT (1e) 1/8 turn max. **DO NOT** overtighten

IMPORTANT: Do NOT use adjustable pliers on supplied 11/16" socket to prevent breakage

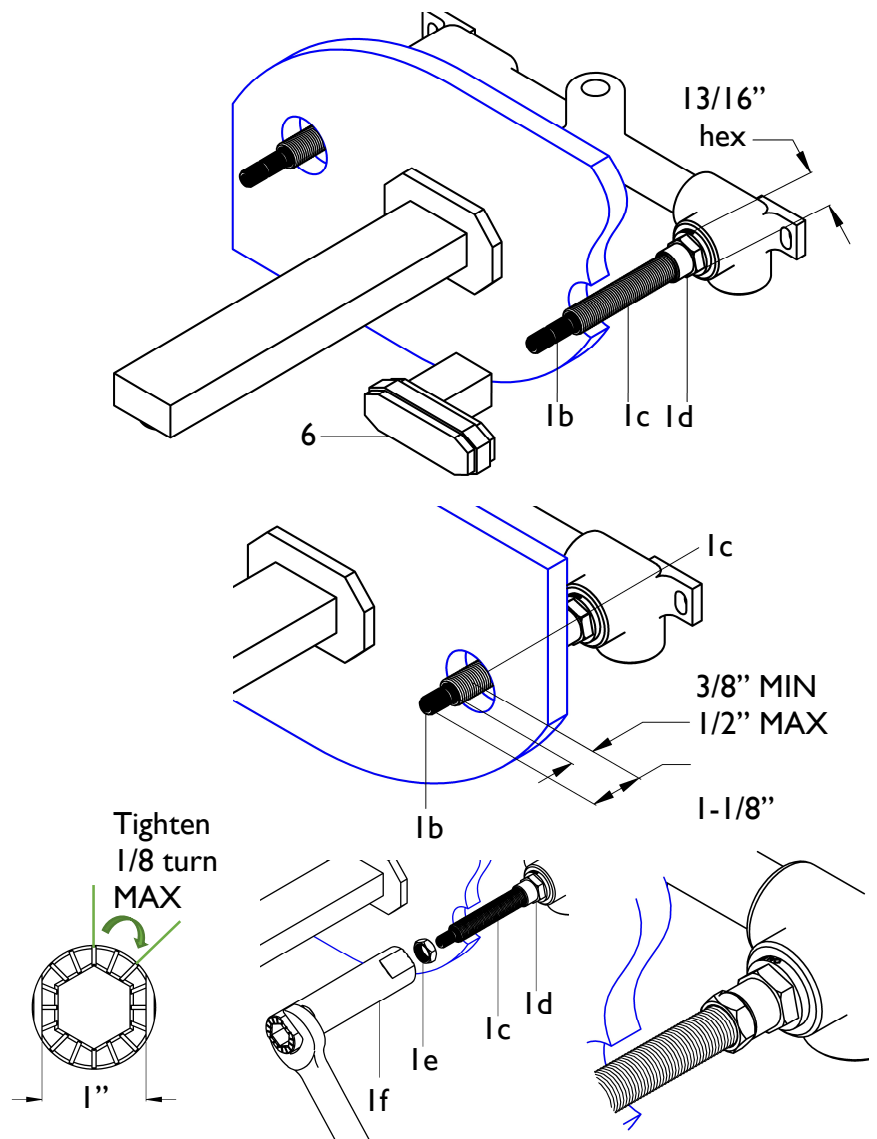
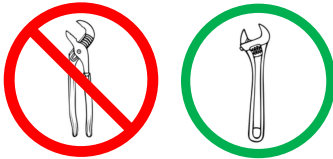

3 INSTALLING BASE & HANDLE

- Place handle BASE (7) onto valve STEM (1b)
- Use level or ruler to align BASES
- Tighten lock NUT (8) onto valve THREADS (1c)

VC202 Lever Handle

- Remove SETSCREW (6a) from handle POST (6b)
- Slide POST (6b) onto valve STEM (1b) and tighten SETSCREW (6a) onto handle POST (6b)

VC202B Block Handle

- Remove SETSCREW (6a) from block BOTTOM (6c)
- Slide block BOTTOM (6c) onto valve STEM (1b) and tighten SETSCREW (6a) onto block BOTTOM (6c)
- Place and press on block TOP (6d) onto block BOTTOM (6c)
- Turn on water supply and check for leaks

