

BATH MIXING PROGRAM  
PROGRAMME DU MITIGEUR POUR LA SALLE DE BAIN  
PROGRAMA MEZCLADORES BAÑO

Art. 39614-39616-39620

Art. 39624-39626-39630

Art. 39644-39646-39650

Art. 39674-39676-39680

Art. 48224-48226-48228

Art. 58214-58216-58218

Art. 58344-58346-58348

Art. 66202-66206-66214

**GESSI** THE  
PRIVATE  
WELLNESS  
COMPANY®



GESSI SpA  
Parco Gessi - 13037 Serravalle Sesia  
(Vercelli) ITALY  
Tel. +39 0163 454111  
Fax +39 0163 459273  
[www.gessi.com](http://www.gessi.com) - [gessi@gessi.it](mailto:gessi@gessi.it)

## **CAUTION - WARNING**

- 1 - **WARNING!!** PLEASE TAKE NOTICE THAT the suggested maximum pressure and/or temperature **MUST NEVER BE EXCEEDED**, as it may damage and/or cause ruptures and/or leakages and/or even break the product, and present a potential hazard and danger to safety, health and/or property. Following are the technical data with respect to the installation of Gessi plumbing products.
  - ▶ Working pressure should not be lower than 0,5 bar (7,25 psi) and not be higher than 5 bar (72 Psi). In case of higher working pressure use a pressure reducer valve.
  - ▶ Maximum test installation pressure: 8 bar (116 psi).
  - ▶ Avoid major pressure differences between hot and cold water supply. Differences in pressure, water with high mineral content, and soapy substances can corrode the internal and external parts of the hoses and slowly weaken the materials thereby causing leakage.
  - ▶ Maximum working temperature for Gessi products is 70°C (158 °F).
- 2 - **WARNING!!** PLEASE TAKE NOTICE THAT the product should never be used as a tool, hammer or for any purposes other than the one it has been designed for.
- 3 - **WARNING!!** PLEASE TAKE NOTICE THAT the product should always be installed and tested by a professional plumber.
- 4 - **WARNING!!** For product installation, please refer to the LOCAL PLUMBING CODE.
- 5 - **WARNING!!** PLEASE TAKE NOTICE THAT electric cables should never be attached to the product as they may present a health and safety hazard.
- 6 - **WARNING!!** PLEASE TAKE NOTICE THAT heavy objects should never be placed on or dropped on the product as they may damage the same and cause splinters, which may present a health and safety hazard.
- 7 - **WARNING!!** PLEASE TAKE NOTICE THAT the instructions manual should carefully read before installation and the installation procedure provided therein must be properly followed and complied with.
- 8 - **WARNING!!** PLEASE TAKE NOTICE THAT during installation the use of excessive force should be avoided in order to prevent damage to the product and/or its components and pieces. **NEVER** force a component or piece into another. **NEVER** force screws or over tighten screws.
- 9 - **WARNING!!** No one uses aluminum **FITTINGS** for water connections.

# ATTENTION - AVERTISSEMENT

- 1 - **ATTENTION!!** NOUS VOUS PRIONS DE TENIR COMPTE QUE la pression et/ou la température maximum suggérée NE DOIT JAMAIS ETRE DEPASSEE, car elle pourrait abîmer et/ou provoquer des ruptures et/ou des fuites et/ou des pannes du produit et, donc, représenter un risque et danger potentiel pour la sécurité, la santé et/ou les choses. Ci-dessous nous indiquons les données techniques concernant l'installation des produits sanitaires Gessi.
  - ▶ La pression de service ne doit pas être inférieure à 0,5 bar (7,25 psi) et supérieure à 5 bar (72 Psi). En cas de pressions de service plus hautes utiliser une soupape de réduction de la pression.
  - ▶ Pression maximum d'essai à l'installation: 8 bar (116 psi).
  - ▶ Eviter des différences de pression importantes entre l'alimentation de l'eau chaude et celle de l'eau froide. Les différences de pression, l'eau avec une haute teneur minérale et les substances savonnées peuvent corroder les parties internes et externes des flexibles et, lentement, affaiblir les matières en provoquant des fuites.
  - ▶ La température maximum de service pour les produits Gessi est 70°C (158 °F).
- 2 - **ATTENTION!!** NOUS VOUS PRIONS DE TENIR COMPTE QUE le produit ne doit jamais être utilisé comme outil, marteau ou pour tout autre but, autre que celui pour lequel il a été conçu.
- 3 - **ATTENTION!!** NOUS VOUS PRIONS DE TENIR COMPTE QUE le produit doit être toujours installé et testé par un plombier professionnel.
- 4 - **ATTENTION!!** Pour l'installation du produit, référez-vous au LOCAL PLUMBING CODE, s.v.p.
- 5 - **ATTENTION!!** NOUS VOUS PRIONS DE TENIR COMPTE QUE les câbles électriques ne doivent jamais être reliés au produit car ils pourraient représenter un danger pour la sécurité et la santé.
- 6 - **ATTENTION!!** NOUS VOUS PRIONS DE TENIR COMPTE QUE les objets lourds ne doivent jamais être posés ou fait tomber sur le produit, car il peuvent provoquer la projection d'éclats et représenter un danger pour la sécurité et la santé.
- 7 - **ATTENTION!!** NOUS VOUS PRIONS DE TENIR COMPTE QUE le manuel d'instructions doit être lu attentivement avant l'installation et que les procédures d'installation prévues ici doivent être adéquatement suivies et respectées.
- 8 - **ATTENTION!!** NOUS VOUS PRIONS DE TENIR COMPTE QUE, pendant l'installation, il faut éviter l'emploi d'une force excessive de sorte à éviter des dommages au produit et/ou à ses composants et pièces. NE JAMAIS forcer un composant ou une pièce à l'intérieur d'une autre. NE JAMAIS forcer les vis et ne pas les serrer excessivement.
- 9 - **ATTENTION!!** Ne pas utiliser raccords de aluminium pour les connexions de l'eau.

# **CUIDADO - ADVERTENCIA**

- 1 - **¡CUIDADO!!** LES ROGAMOS QUE TENGAN EN CUENTA QUE NUNCA la presión y/o la temperatura máxima aconsejada NO TIENE QUE SER SUPERADA, ya que podría dañar y/o causar rupturas y/o pérdidas y/o averías del producto y, por lo tanto, representar un riesgo y un peligro potencial para la seguridad, la salud y/o la propiedad. A continuación Les proporcionamos los datos técnicos relativos a la instalación de los productos de grifería Gessi.
  - ▶ La presión de ejercicio no tiene que ser inferior a 0,5 bar (7,25 psi) y superior a 5 bar (72 Psi). En caso de presiones de ejercicio mayores, utilicen una válvula de reducción de la presión.
  - ▶ Presión máxima de ensayo durante la instalación: 8 bar (116 psi).
  - ▶ Eviten grandes diferencias de presión entre la alimentación del agua fría y aquella del agua caliente. Las diferencias de presión, el agua con un alto contenido mineral y las sustancias jabonosas pueden corroer las partes interiores y exteriores de los flexos y, lentamente, e, lentamente, debilitar los materiales causando pérdidas.
  - ▶ La temperatura máxima de ejercicio para los productos Gessi es 70°C (158 °F).
- 2 - **¡CUIDADO!!** LES ROGAMOS QUE TENGAN EN CUENTA QUE nunca el producto no tiene que ser utilizado como en lugar de herramienta, martillos o para finalidades diferentes de aquellas para las cuales ha sido diseñado.
- 3 - **¡CUIDADO!!** LES ROGAMOS QUE TENGAN EN CUENTA QUE el producto tiene que ser instalado y ensayado siempre por un fontanero profesional.
- 4 - **¡CUIDADO!!** Para la instalación del producto Les rogamos que contacten con el LOCAL PLUMBING CODE.
- 5 - **¡CUIDADO!!** LES ROGAMOS QUE TENGAN EN CUENTA QUE nunca los cables eléctricos no tiene que ser conectado al producto ya que podrían representar un peligro para la seguridad y la salud.
- 6 - **¡CUIDADO!!** LES ROGAMOS QUE TENGAN EN CUENTA QUE nunca objetos pesados no tienen que ser apoyados o dejados caer sobre el producto ya que podrían causar la proyección de astillas y representar un peligro para la seguridad y la salud.
- 7 - **¡CUIDADO!!** LES ROGAMOS QUE TENGAN EN CUENTA QUE el manual de instrucción tiene que ser leído con cuidado antes de la instalación y que hay que cumplir adecuadamente con los procedimientos de instalación proporcionados.
- 8 - **¡CUIDADO!!** LES ROGAMOS QUE TENGAN EN CUENTA QUE, durante la instalación, hay que evitar el uso de una fuerza excesiva de manera que se puedan evitar daños del producto y/o componentes y piezas. NO fuercen NUNCA un componente o una pieza, la una dentro de la otra. NO fuercen NUNCA los tornillos y no los cierren excesivamente.
- 9 - **¡CUIDADO!!** No utilicen ACCESORIOS de aluminio para las conexiones del agua.



ART. 39614

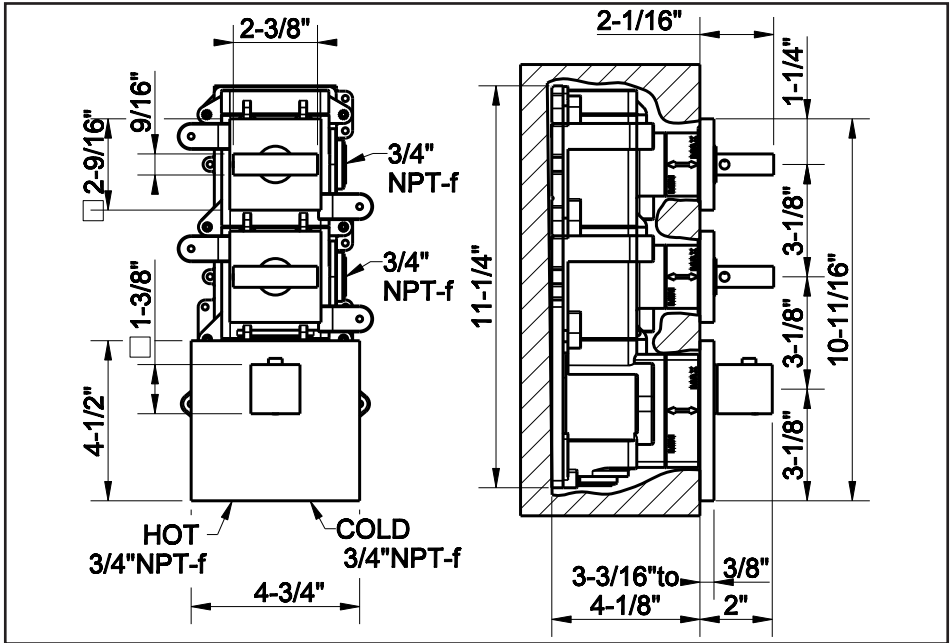

ART. 39616

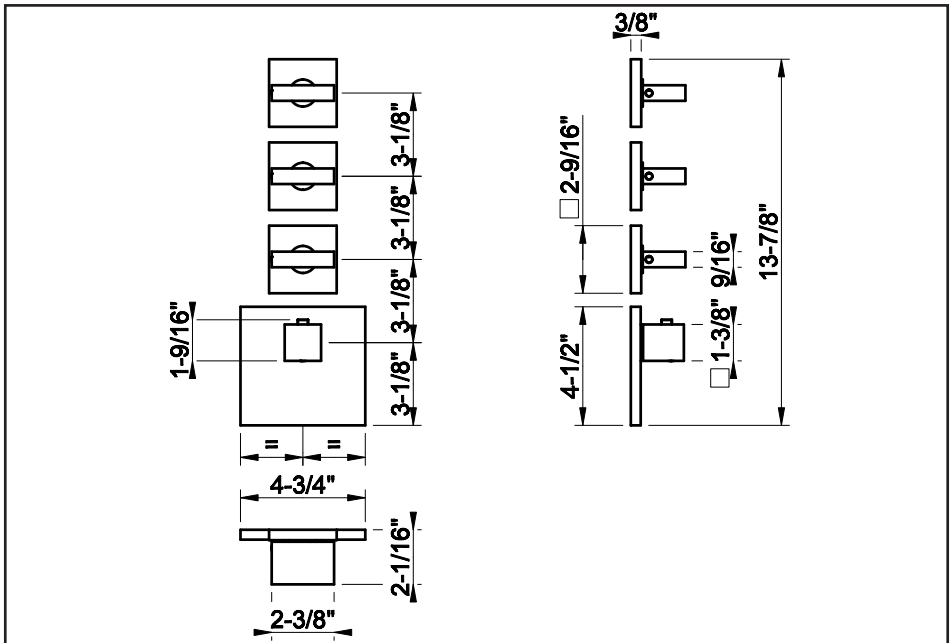





ART. 39624

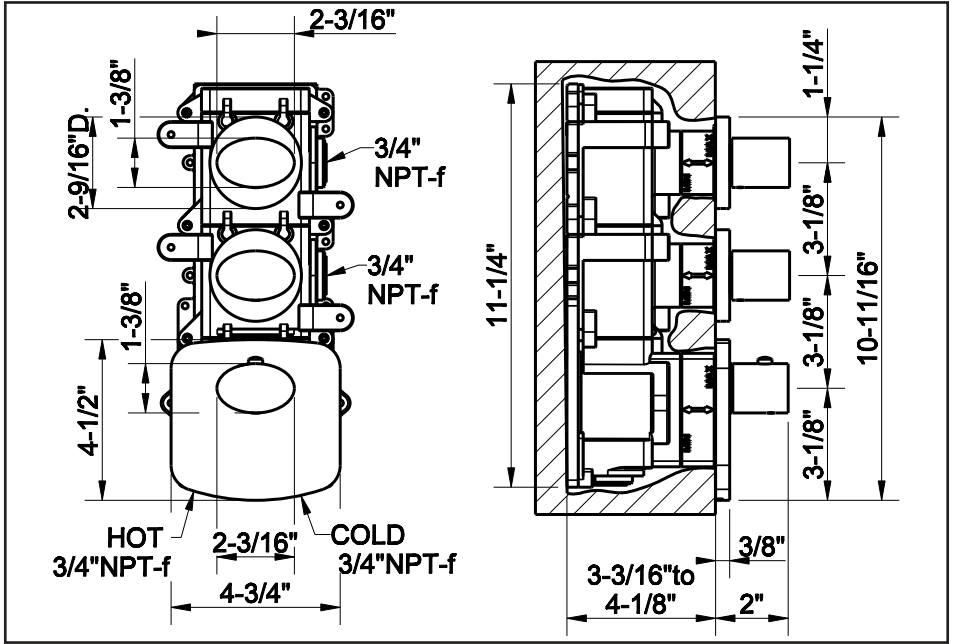

ART. 39626

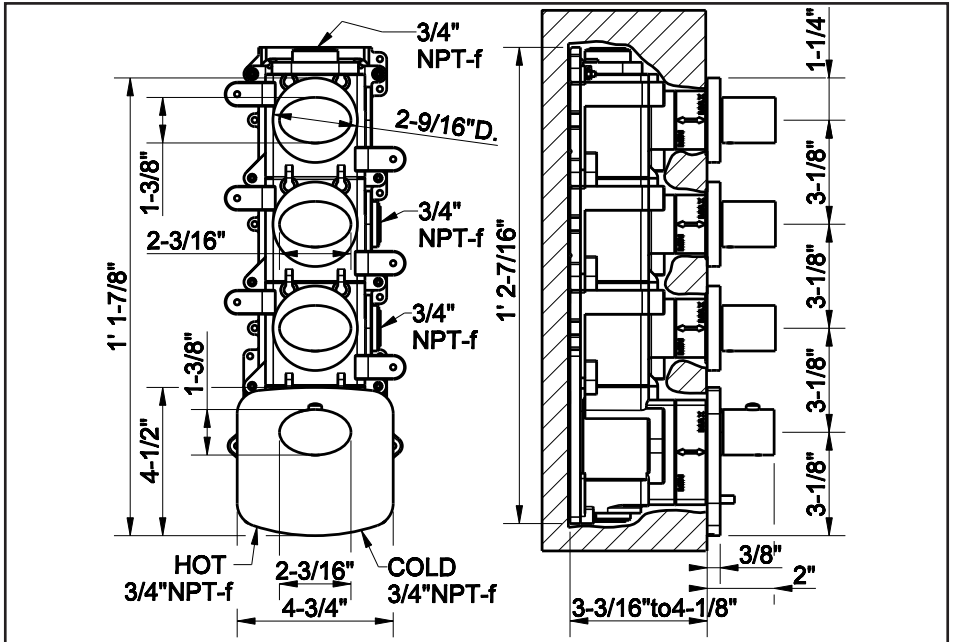



ART. 39630

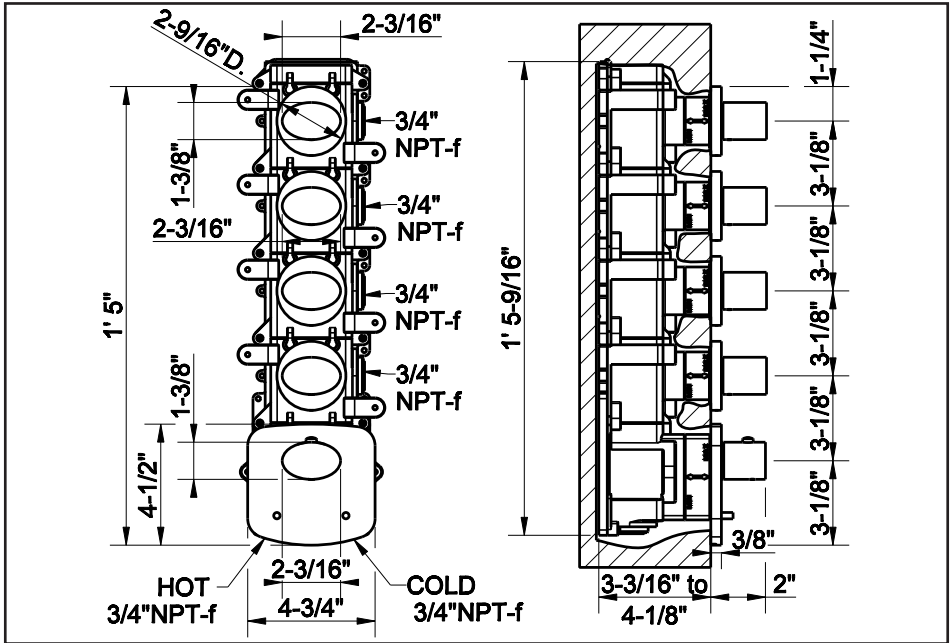



ART. 39644

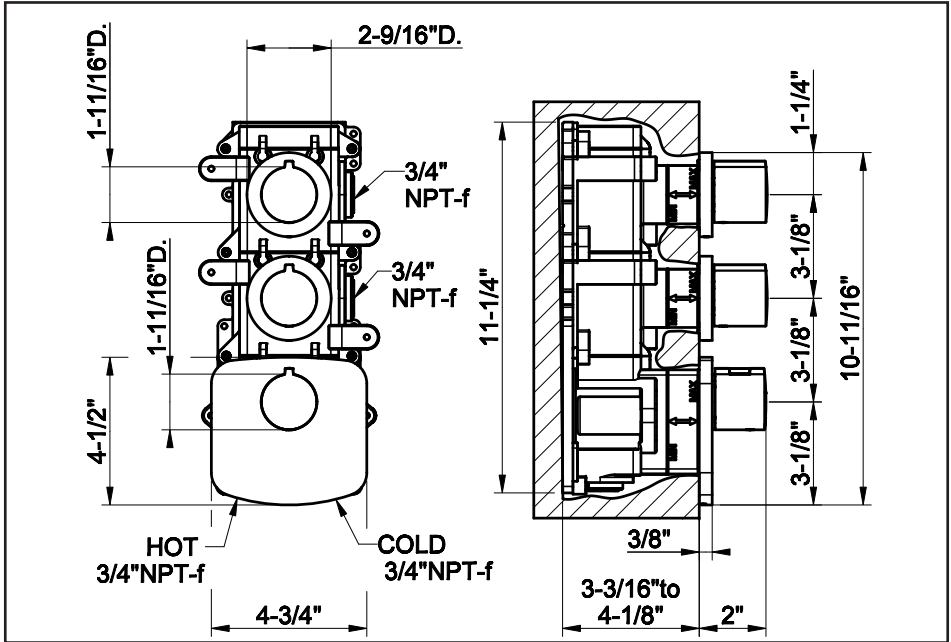

ART. 39646

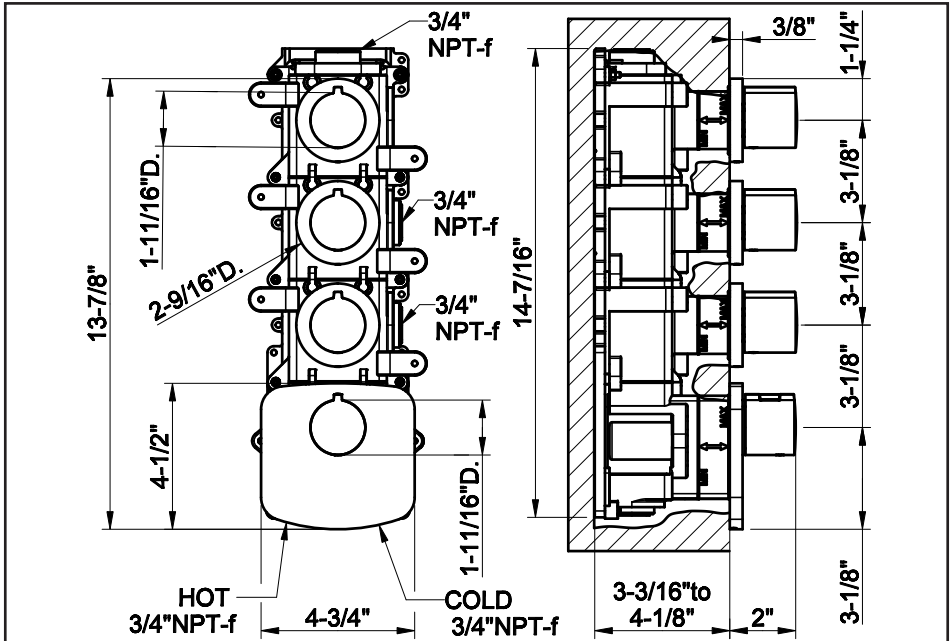



ART. 39650

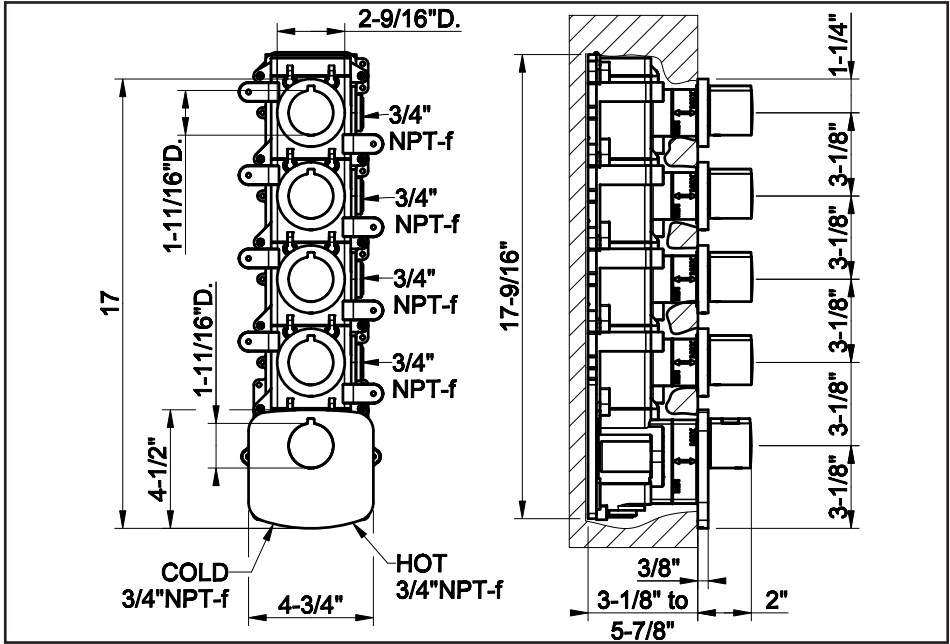





ART. 39680

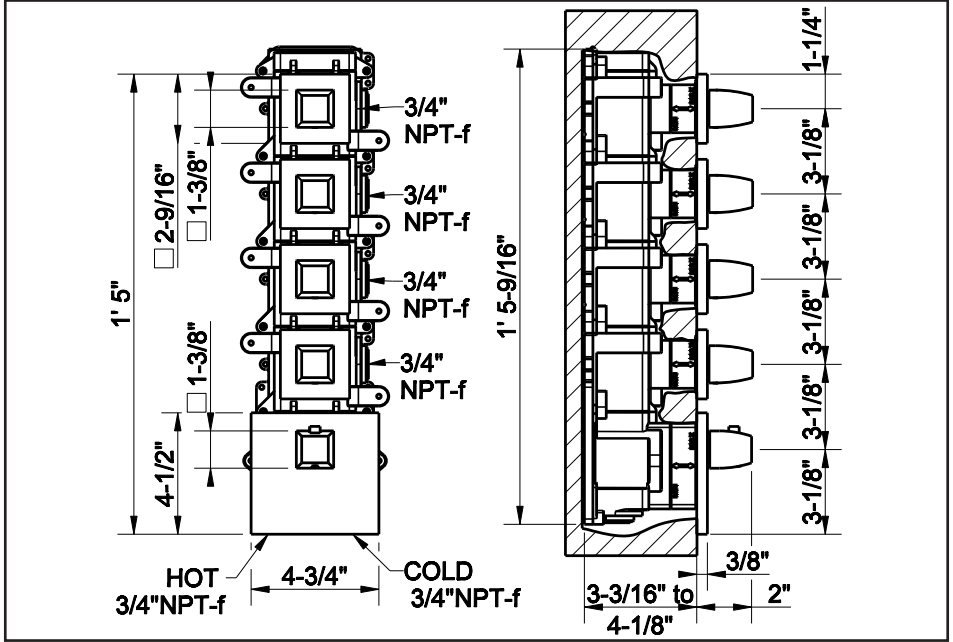



ART. 58214

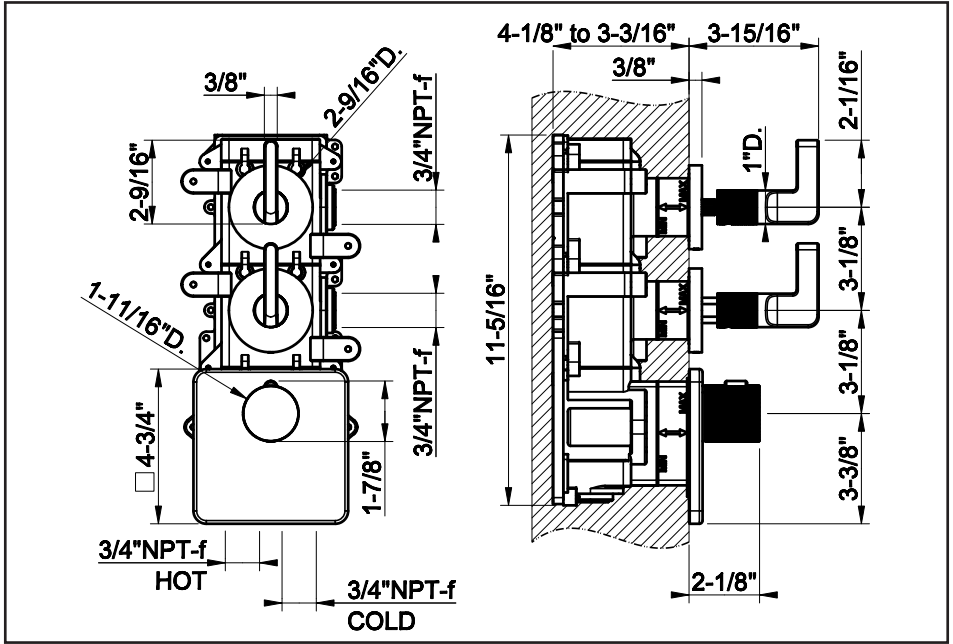

ART. 58216

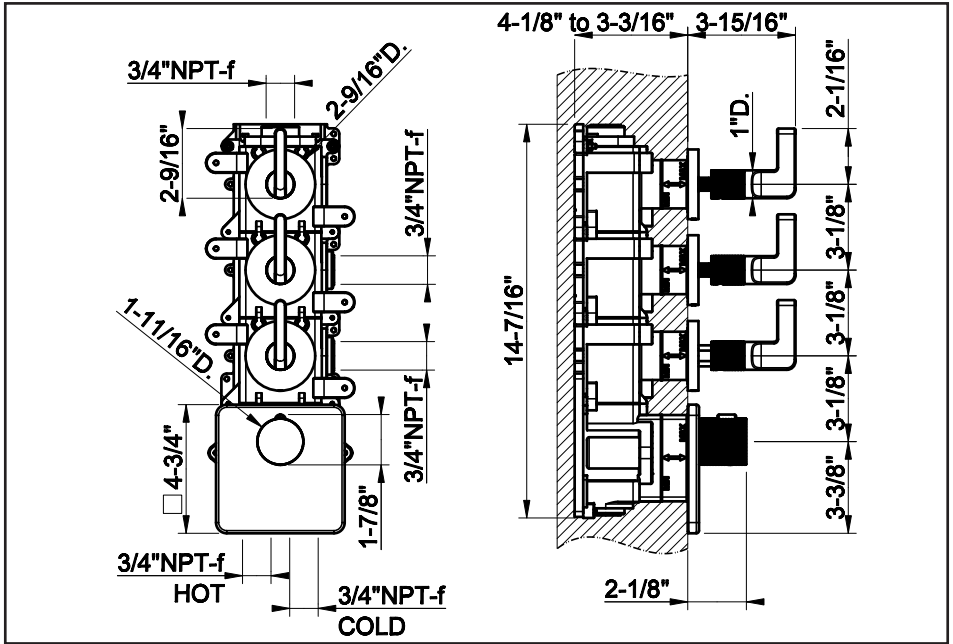



ART. 58218

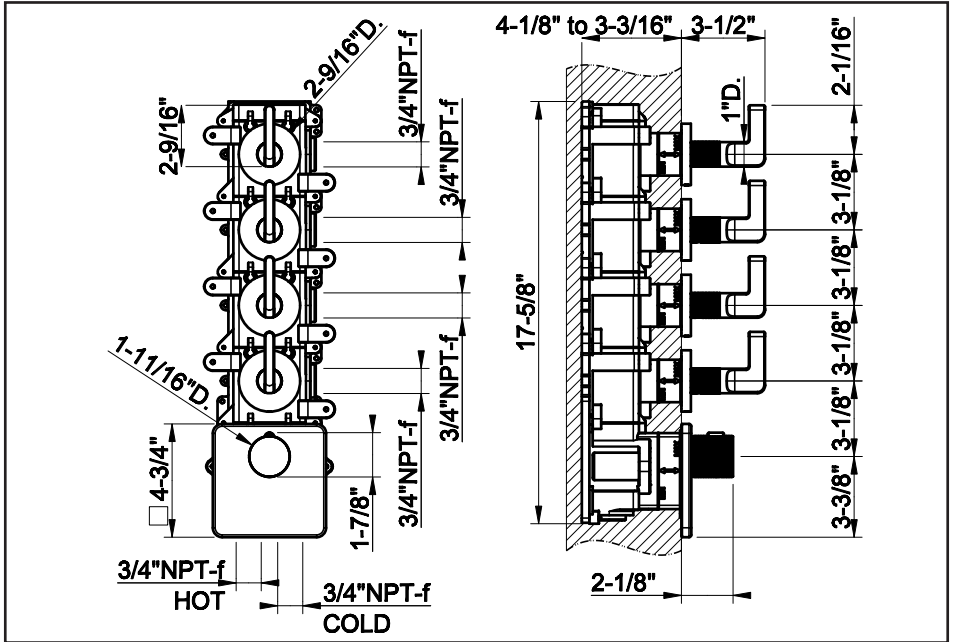



ART. 58344

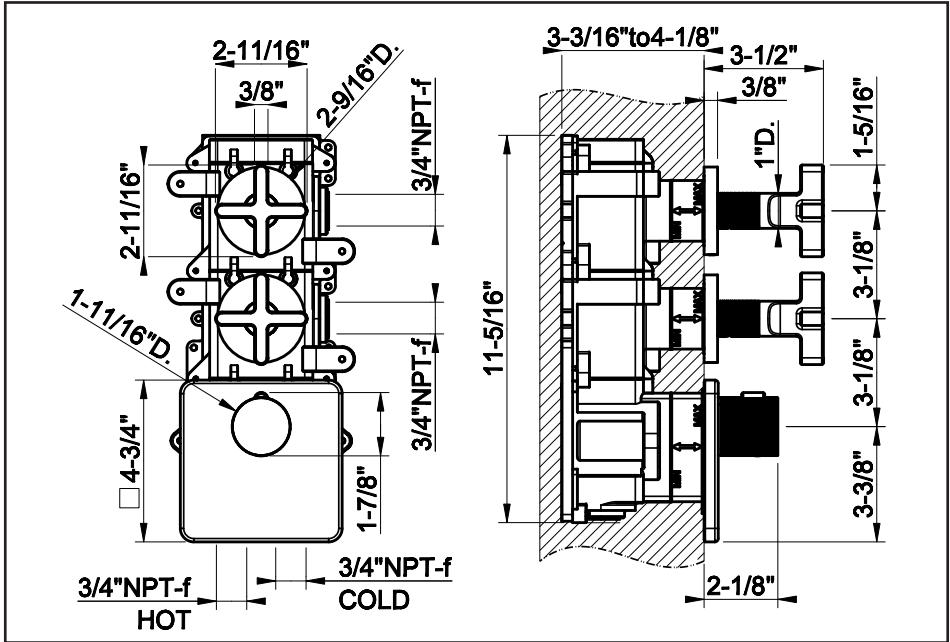

ART. 58346

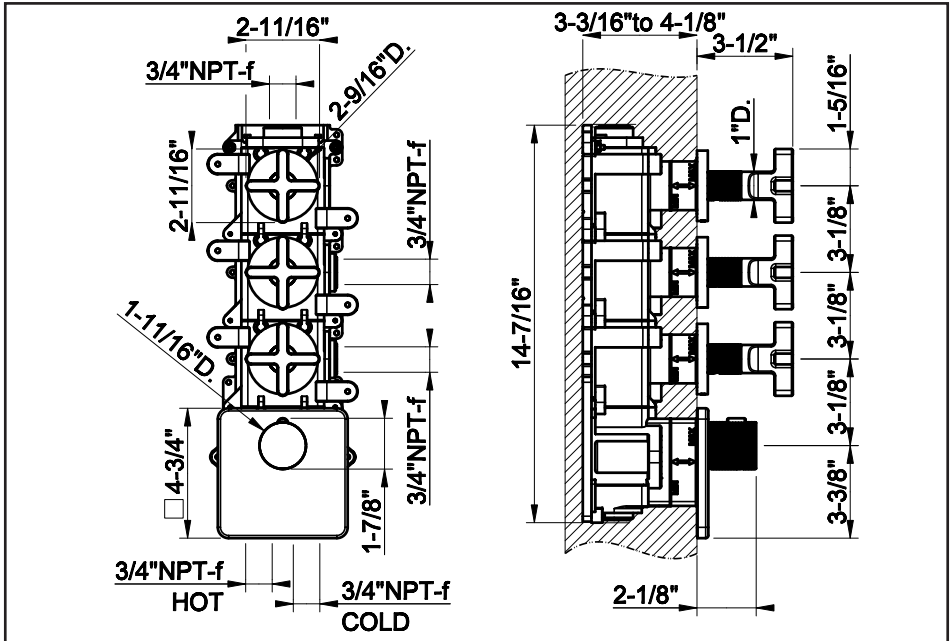





ART. 66202

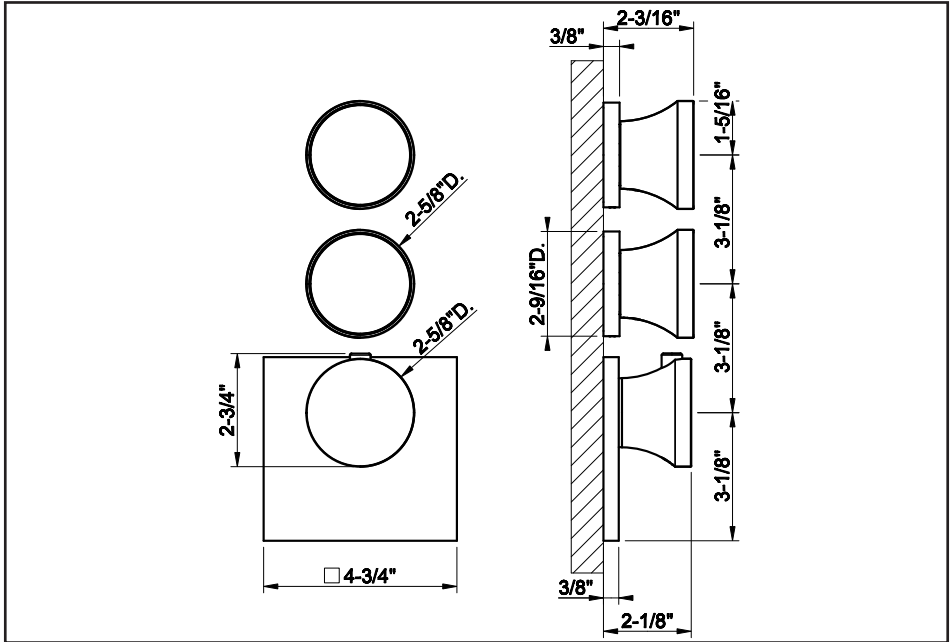

ART. 66206

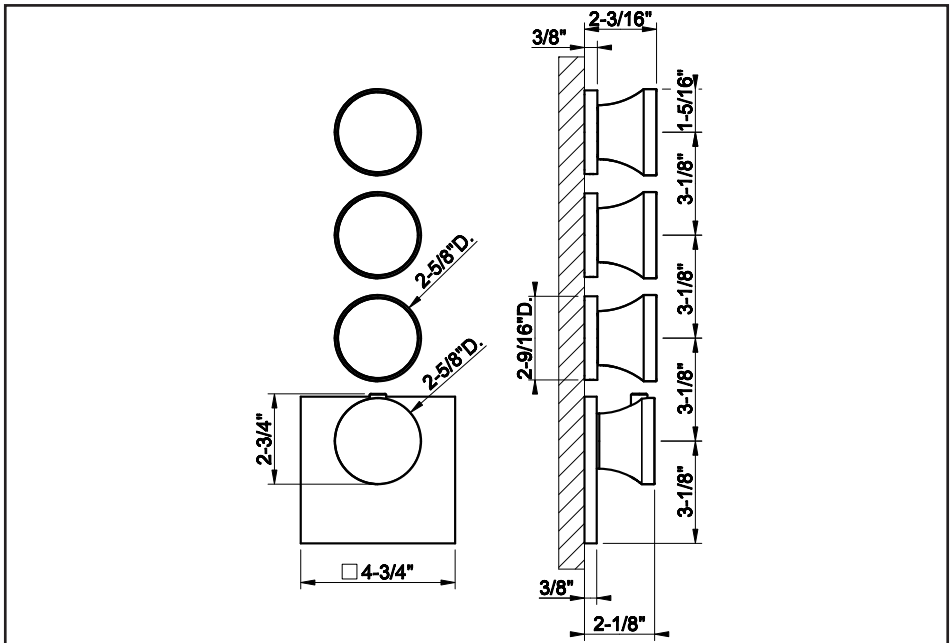



ART. 66214

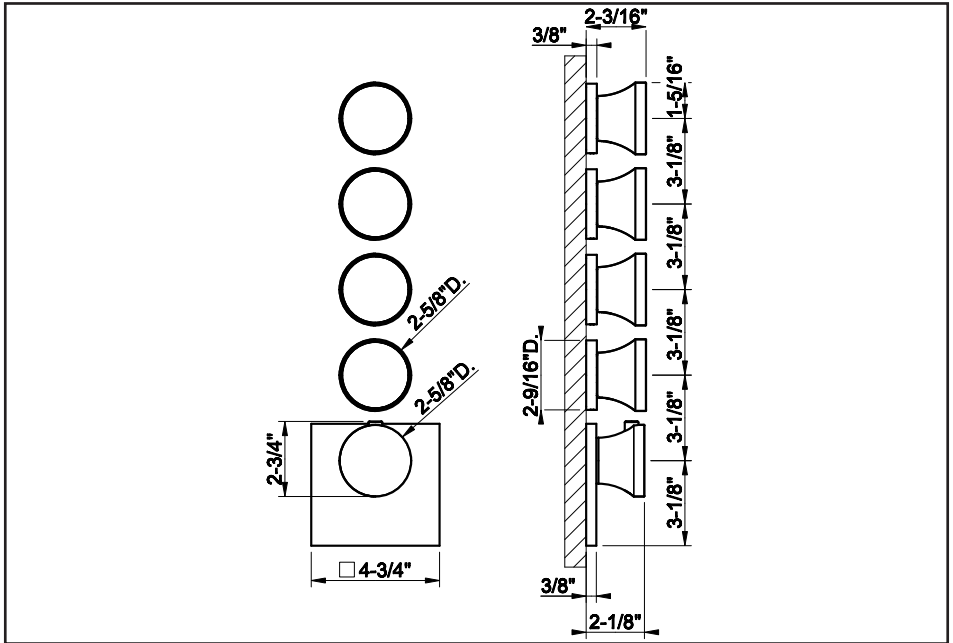



**Technical data of the mixer:**

- Minimum working pressure 7,25 psi [0,5 bar]
- Maximum working pressure 72 psi [5 bar]
- Recommended working pressure 43,5 psi [3 bar] (in case of water pressure higher than 72 psi [5 bar] it is recommended to install pressure reducers)
- Maximum test installation pressure 116 psi [8 bar]
- Avoid major pressure differences between hot and cold water supply. Differences in pressure, water with high mineral content, and soapy substances can corrode the internal and external parts of the hoses and slowly weaken the materials thereby causing leakage
- Safety lock at 100°F [38°C]
- Safety lock for max temperature at 120°F [49°C]
- Mixer's minimum infeed operating temperature 37°F [3°C] - recommended 59°F [15°C] - COLD
- Mixer's maximum infeed operating temperature 176°F [80°C] - recommended 149°F [65°C] - HOT
- Recommended thermal differential 122°F [50°C]
- Safety system with flow stop in case of lack of one of the two waters

**Operation:**

- Either with gas or electric accumulation boilers
- Centralised systems
- Wall boilers
- Filters in stainless steel for the treatment of impurities

**Warning:** contact the plumber for the choice of the best water heating device.

**Données techniques du mitigeur:**

- Pression minimum d'exercice 7,25 psi [0,5 bar]
- Pression maximum d'exercice 72 psi [5 bar]
- Pression d'exercice conseillée 43,5 psi [3 bar] (en cas de pression de l'eau supérieure aux 72 psi [5 bar] nous conseillons l'installation de réducteurs de pression)
- Pression maximum d'essai à l'installation 116 psi [8 bar]
- Eviter des différences de pression importantes entre l'alimentation de l'eau chaude et celle de l'eau froide. Les différences de pression, l'eau avec une haute teneur minérale et les substances savonnées peuvent corroder les parties internes et externes des flexibles et, lentement, affaiblir les matières en provoquant des fuites
- Bloc de sécurité à 100°F [38°C]
- Blocage de sécurité pour température max à 120°F [49°C]
- Température minimum d'exercice en entrée dans le mitigeur 37°F [3°C] - conseillée 59°F [15°C] - FROIDE
- Température maximum d'exercice en entrée dans le mitigeur 176°F [80°C] - conseillée 149°F [65°C] - CHAUDE
- Différentiel thermique conseillé 122°F [50°C]
- Système de sécurité avec le bloc de la distribution en cas de manque d'une des deux eaux

**Fonctionnement:**

- Soit avec des chauffe-eaux à gaz, électriques à accumulation
- Installations centrales
- Chaudières au mur
- Filtrés en acier inox pour le traitement des impuretés

**Attention:** consulter le plombier pour le choix du dispositif de réchauffement de l'eau le plus approprié.



**Datos técnicos mezclador:**

- Presión mínima de ejercicio 7,25 psi [0,5 bar]
- Presión máxima de ejercicio 72 psi [5 bar]
- Presión de ejercicio aconsejada 43,5 psi [3 bar] (en caso de presión del agua superior a los 72 psi [5 bar], les aconsejamos instalar unos reductores de presión)
- Presión máxima de ensayo durante la instalación 116 psi [8 bar]
- Eviten grandes diferencias de presión entre la alimentación del agua fría y aquella del agua caliente. Las diferencias de presión, el agua con un alto contenido mineral y las sustancias jabonosas pueden corroer las partes interiores y exteriores de los flexos y, lentamente, e, lentamente, debilitar los materiales causando pérdidas
- Bloqueo de seguridad a 100°F [38°C]
- Bloqueo de seguridad para temperatura máxima de 120°F [49°C]
- Temperatura mínima de ejercicio en entrada del mezclador 37°F [3°C] - recomendada 59°F [15°C] - FRÍA
- Temperatura máxima de ejercicio en entrada del mezclador 176°F [80°C] - recomendada 149°F [65°C] - CALIENTE
- Diferencial térmico recomendado 122°F [50°C]
- Sistema de seguridad con bloqueo de seguridad en caso de falta de una de las dos aguas

**Funcionamiento:**

- Con calderas tanto de gas como eléctricas por acumulación
- Instalaciones centralizadas
- Calderas murales
- Filtros de acero inoxidable para el tratamiento de las impurezas

**Cuidado:** *consúltense con Su fontanero para elegir el dispositivo de calefacción del agua más adecuado.*

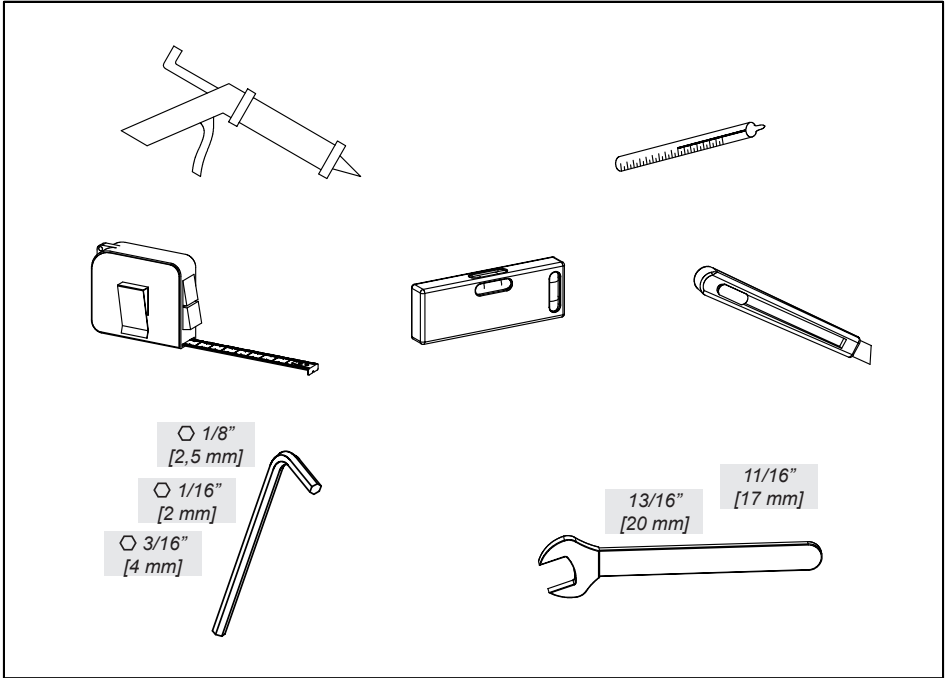

**Before installation and setting to work**

**Attention!** The feeding pipes have to be rinsed thoroughly before the installation of the product, so that no shavings, welding or hemp residual or other dirt can be found in the pipes. Foreign bodies can enter the product through the rinsed pipes or the general water plant and could damage the washers/ring washers. So filters should be installed also on the general system. The warranty does not cover the claim on this product resulting from filters not being installed in the main water system. See the “MANUFACTURER’S LIMITED WARRANTY”.

**Avant l’installation et la mise en fonction.**

**Attention!** Les tubes d’alimentation doivent être rincés avec soin avant l’installation du produit, de façon qu’il ne reste pas de riblons, de restes de soudure ou de chanvre, ou d’autres saletés à l’intérieur des tubes. A travers les tuyauteries qui ne sont pas bien rincées ou à travers l’installation hydrique générale, des corps étrangers peuvent entrer dans le produit et abîmer les joints/les joints à anneau. On recommande ainsi d’installer des filtres également sur le système général. La garantie ne couvre pas les mauvais fonctionnements de ce produit dans le cas où les filtres ne soient pas installés au réseau hydraulique central. Voir “LIMITATION DE GARANTIE”.

**Antes de la instalación y la puesta en función**

**¡Cuidado!** Los tubos de alimentación tienen que ser enjuagados a fondo antes de la instalación del producto de manera que no queden virutas, residuos de soldadura o cáñamo u otras impurezas en los tubos. A través de tubería no bien enjuagada o de la red hídrica en general, en el producto pueden entrar cuerpos extraños capaces de dañar los empaques/anillos de cierre. Les recomendamos por lo tanto que instalen los filtros en la planta general también. La garantía no cubre reclamaciones sobre este producto que procedan de los filtros, el cual no se instalaron en el sistema hídrico principal. Mirar los “ LIMITES DE GARANTIA DEL PRODUCTOR”.





**WARNING:** *the representation of the installation of the thermostatic mixer is based only on item with 2 outlets since it is the same for all previously mentioned products.*

**ATTENTION:** *la représentation de l'installation du mitigeur thermostatique se base seulement sur l'article à 2 sorties étant la même pour tous les produits énumérés auparavant.*

**CUIDADO:** *la representación de la instalación del mezclador termostático se basa en la referencia de 2 salidas, con ser ésta la misma para todos los productos anteriormente mencionados.*

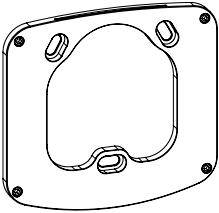

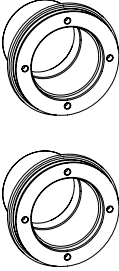
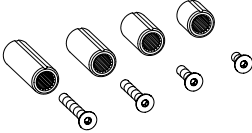
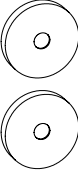
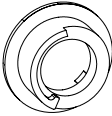
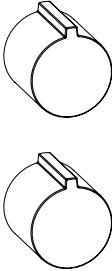
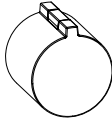
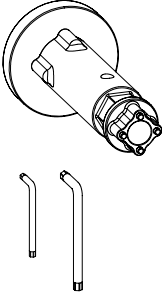
<p><b>A</b></p> 	<p><b>B</b></p> 	<p><b>C</b></p> 
<p><b>D</b></p> 	<p><b>E1</b></p> 	<p><b>F</b></p> 
<p><b>G</b></p> 	<p><b>H</b></p> 	<p><b>L</b></p> 



**Package content:**

- A - Fastening plate
- B - Plate fastening screws
- C - Fastening bushes
- D - Extension set
- E - Finish plate
- F - Temperature adjustment stop
- G - Control handle
- H - Handle for temperature adjustment
- L - Installation wrenches

**Contenu de l'emballage:**

- A - Plaque de fixation
- B - Vis de fixation plaque
- C - Douilles de fixation
- D - Jeu rallonge
- E - Plaque en finition
- F - Arrêts de réglage de la température
- G - Poignée de commande
- H - Poignée réglage température
- L - Clés pour l'installation

**Contenido de la caja:**

- A - Placa de fijación
- B - Tornillos de fijación plancha
- C - Buje de fijación
- D - Juego extensión
- E - Placa de acabado
- F - Retén de regulación de la temperatura
- G - Maneta de mando
- H - Maneta para la regulación de la temperatura
- L - Llaves de instalación



Fig. 1

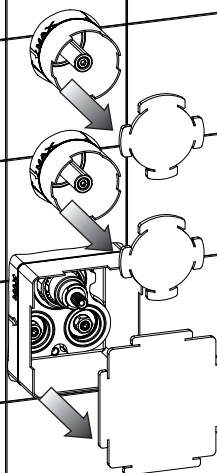

Fig. 2

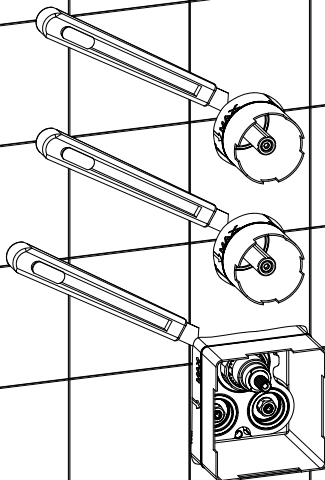

Fig. 3

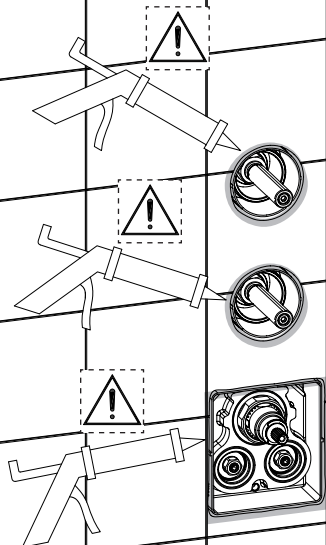
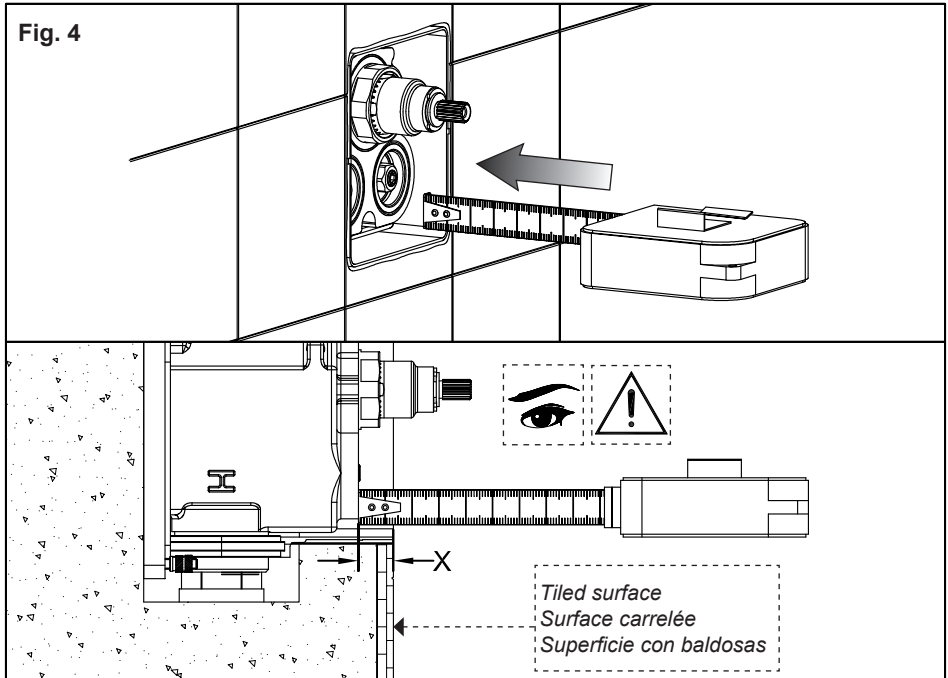

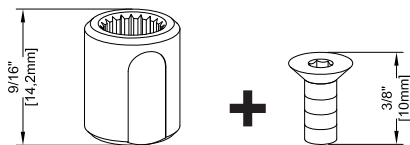

Fig. 4





**0" to 1/8"**  
**[0mm ÷ 3mm]**



**1/8" to 3/8"**  
**[3mm ÷ 10mm]**

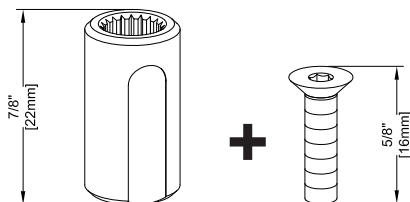

**3/8" to 11/16"**  
**[10mm ÷ 17mm]**

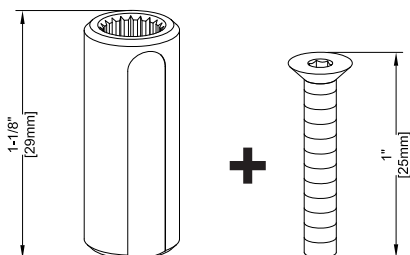

**11/16" to 1"**  
**[17mm ÷ 25mm]**

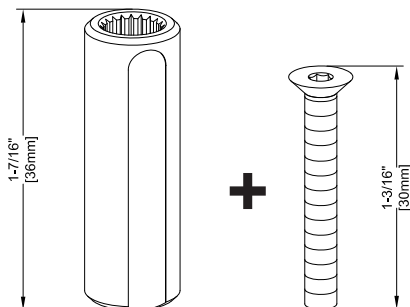



Fig. 5

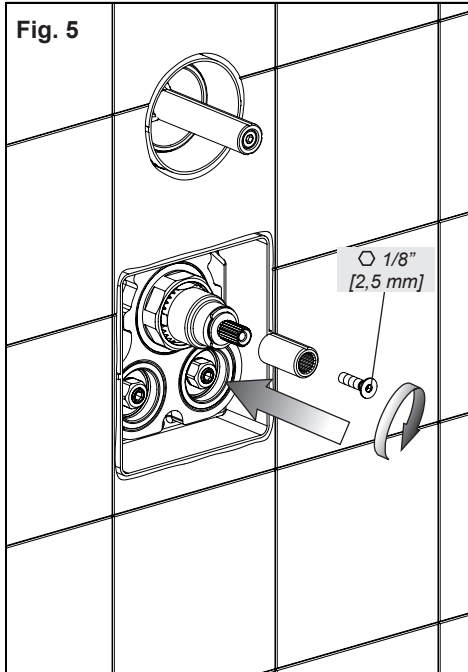



Fig. 6

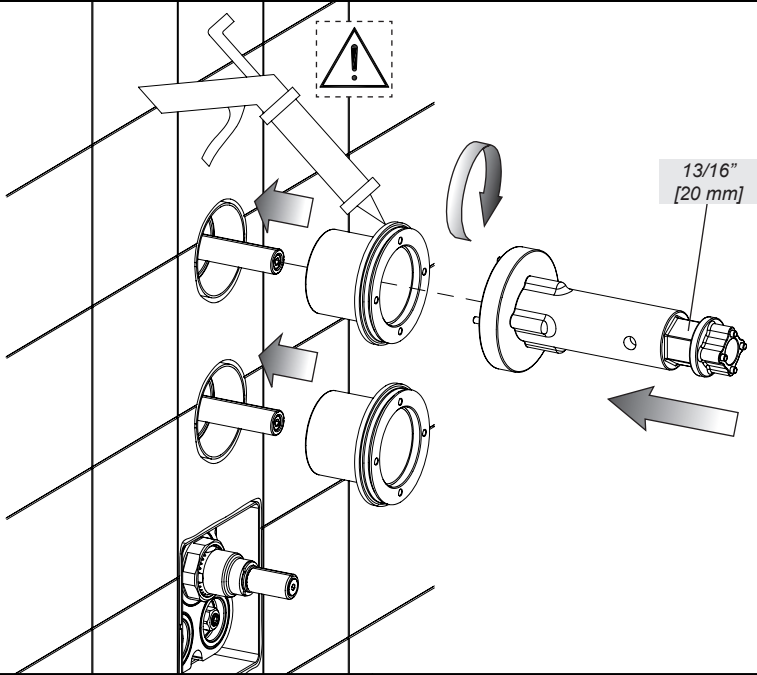

Fig. 7

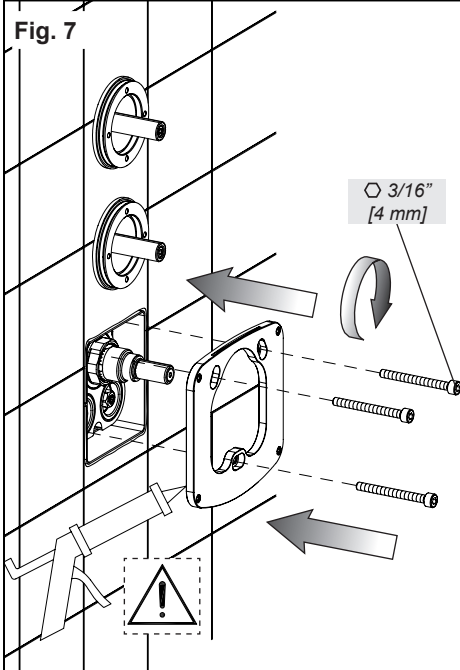

Fig. 8

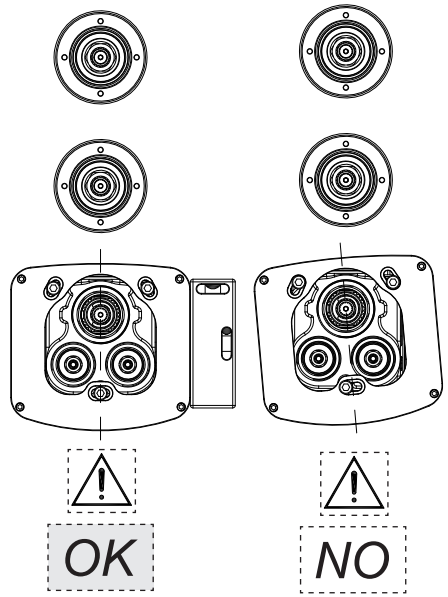



Fig. 9a

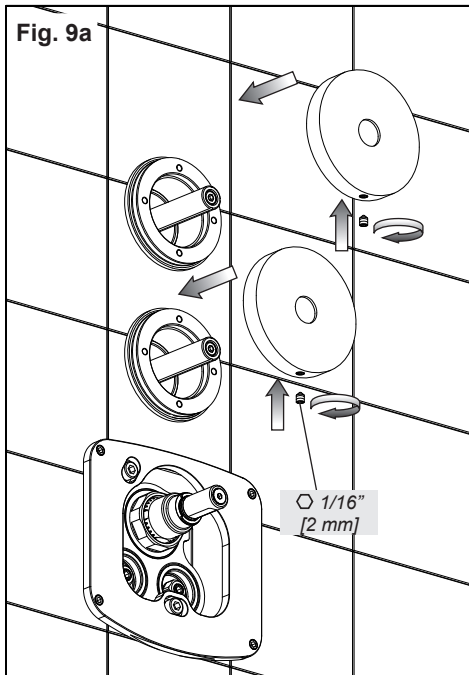

Fig. 9b

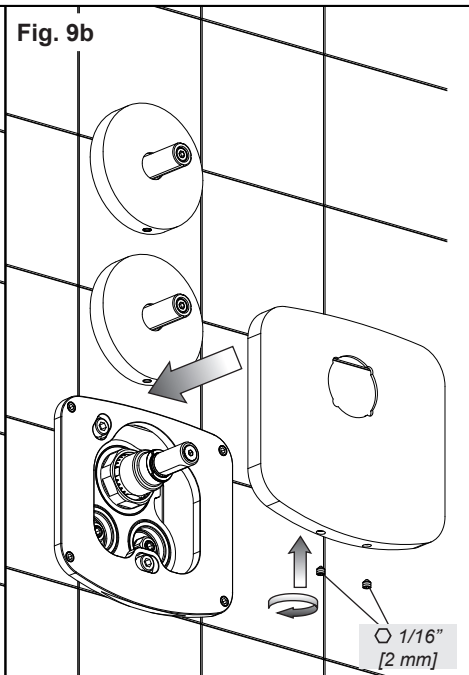

Fig. 10

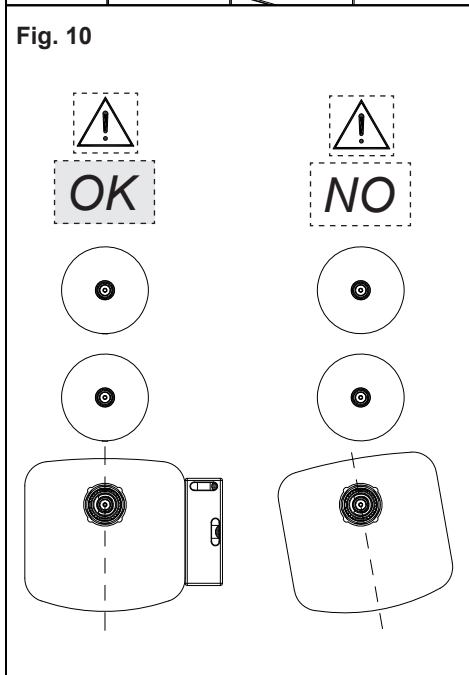

Fig. 11

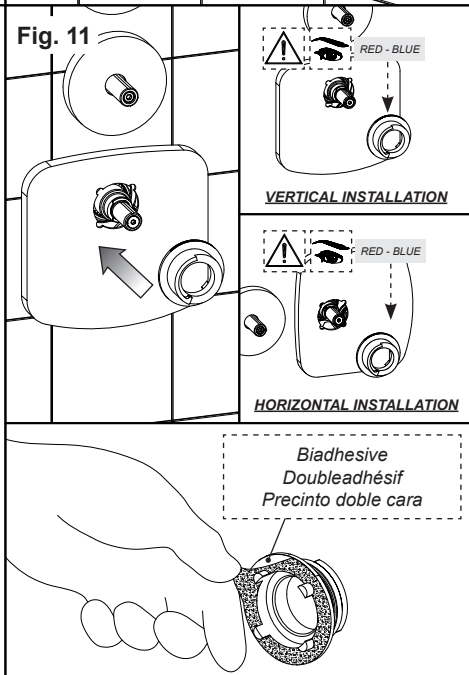



Fig. 12

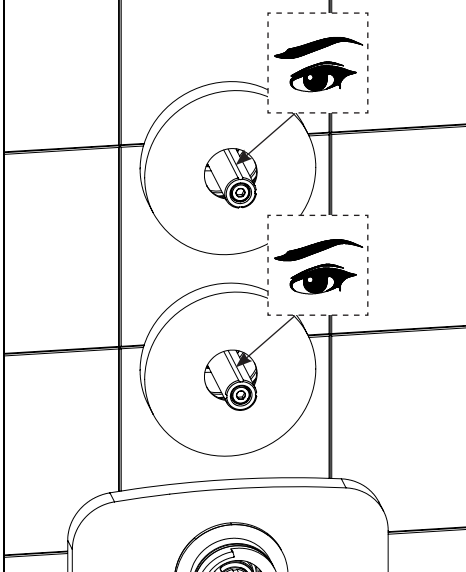

Fig. 13

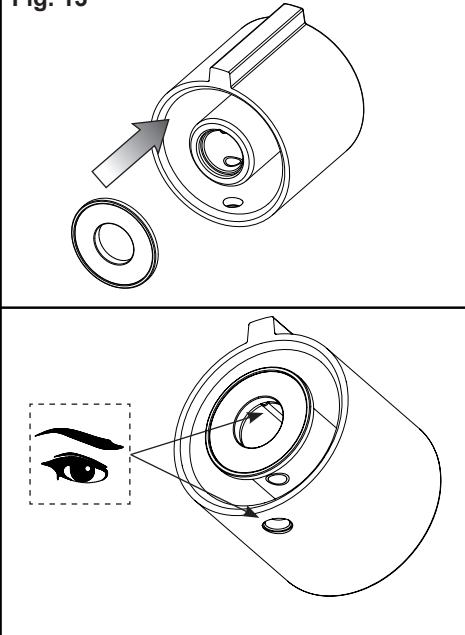

Fig. 14

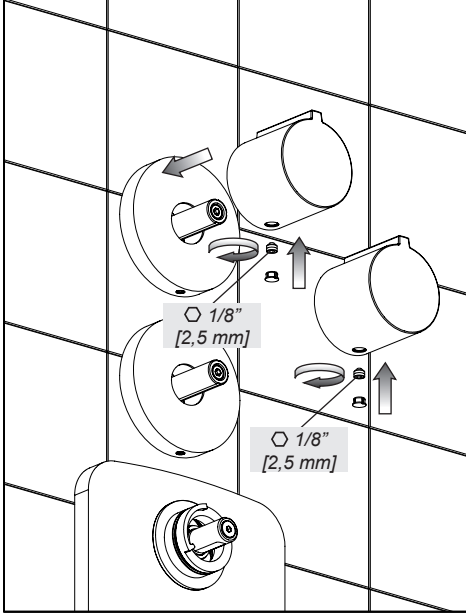

Fig. 15

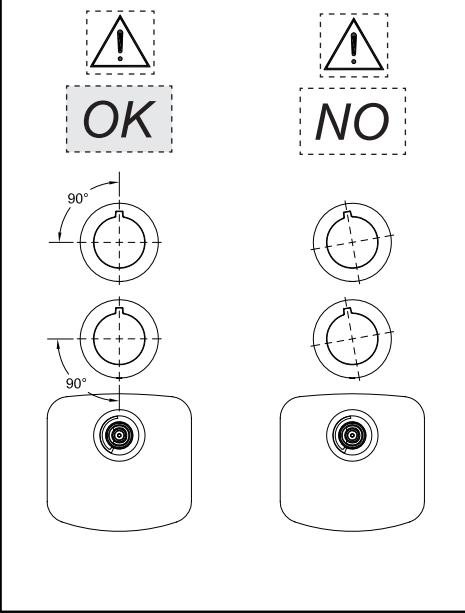
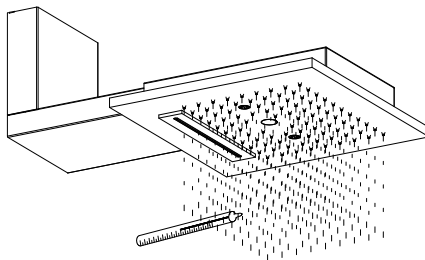
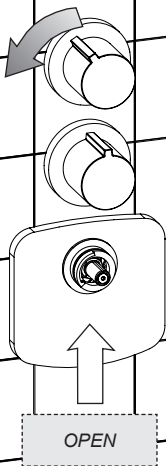

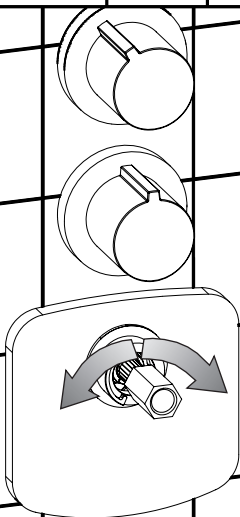

Fig. 16



~~100°F [38°C]~~

Fig. 17



○ 11/16" [17 mm]

Fig. 18

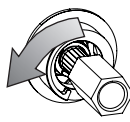

+

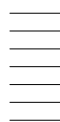

100°F [38°C]

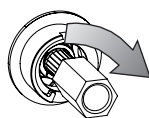
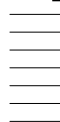
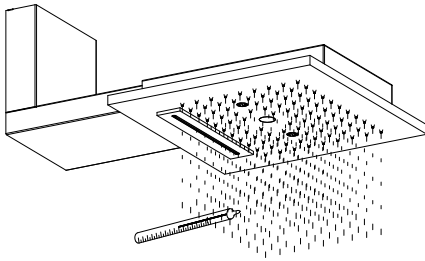



Fig. 19



**100°F [38°C]**



Fig. 20

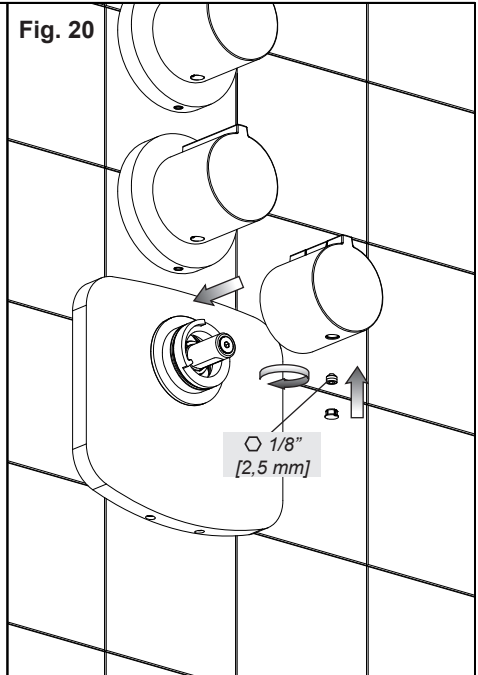
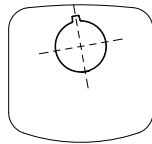
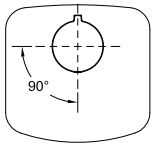

Fig. 21



**WARNING!**

*The installation of the built-in thermostatic mixer is over, before use read the section concerning the operation in the following pages.*

**ATTENTION!**

*L'installation du mitigeur thermostatique encastré est terminée, avant l'emploi voir la section relative au fonctionnement dans les pages suivantes.*

**¡CUIDADO!**

*La instalación del mezclador termostático por empotrar se ha acabado; antes de su utilización consulten la sección relativa al funcionamiento proporcionada en las páginas a continuación.*

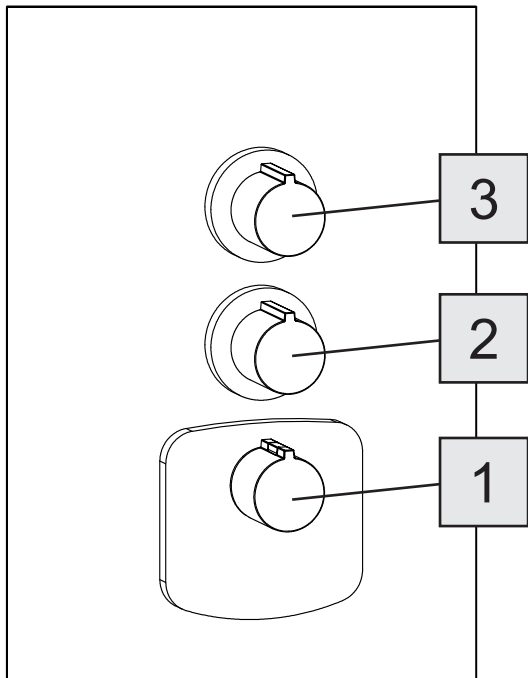

<p><b>1</b></p>	<p>Temperature adjustment control - Commande pour le réglage de la température - Mando para la regulación de la temperatura</p>
<p><b>2</b></p>	<p>Opening control outlet N°1 - Commande d'ouverture sortie N°1 - Mando de abertura salida N°1</p>
<p><b>3</b></p>	<p>Opening control outlet N°2 - Commande d'ouverture sortie N°2 - Mando de abertura salida N°2</p>



1

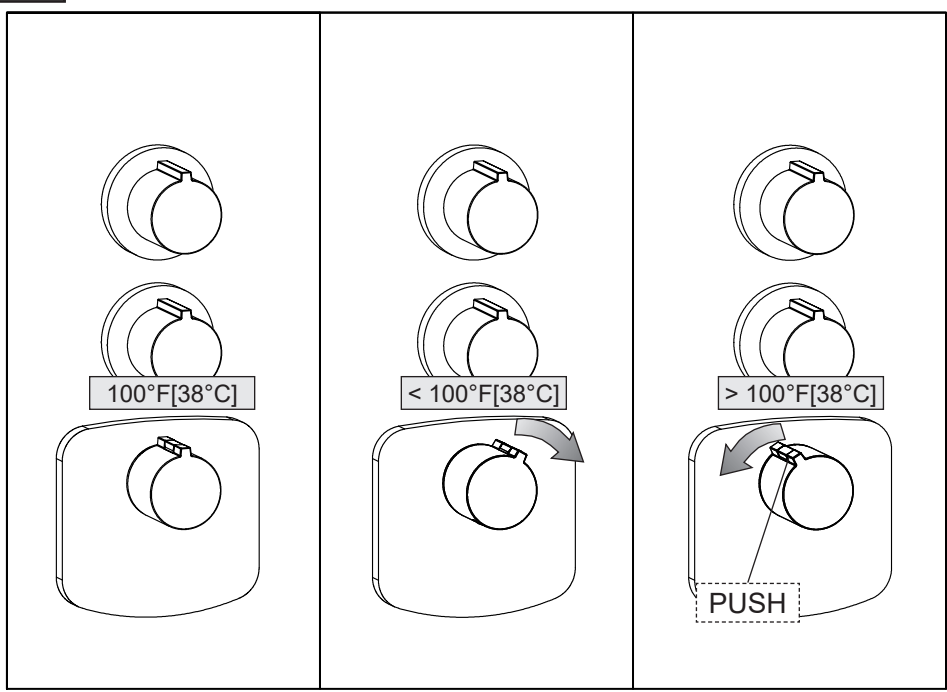



2-3

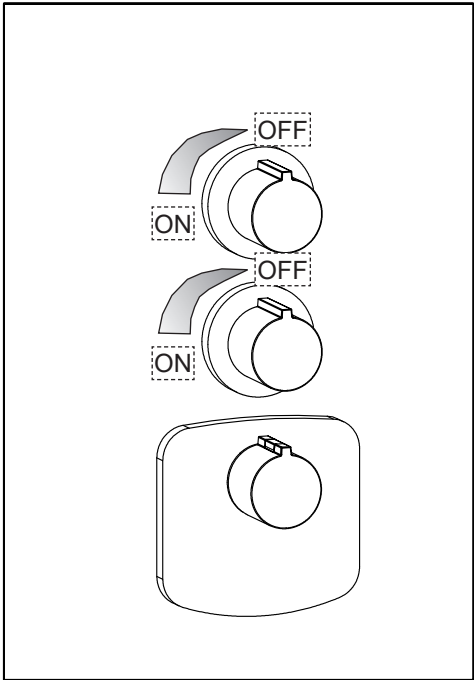

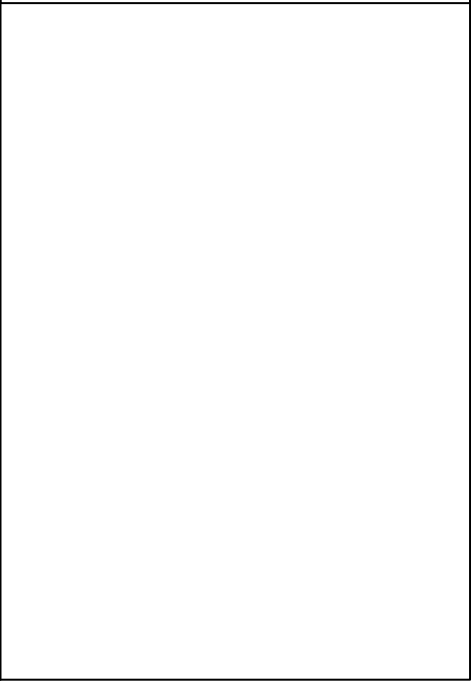
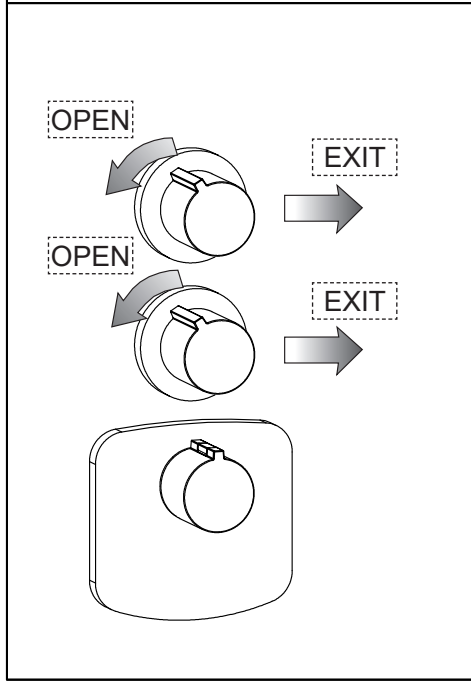
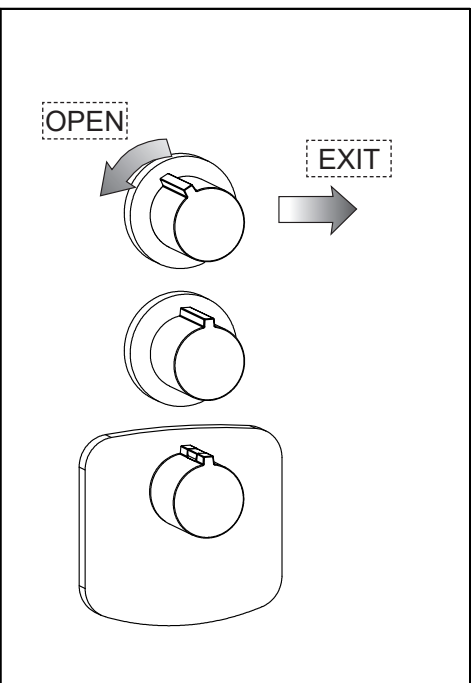
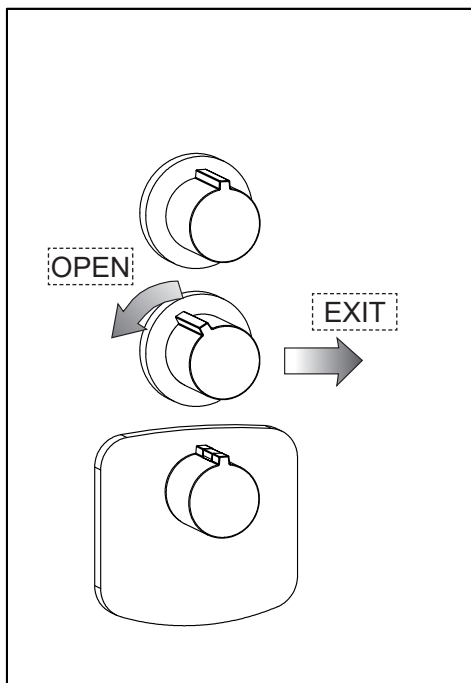



### **MAINTENANCE**

- Should it be necessary to replace one or more components, contact an authorized retailer or visit [WWW.GESSI.COM](http://WWW.GESSI.COM)
- Product maintenance should be made only by qualified staff

### **ENTRETIEN**

- S'il est nécessaire de remplacer un ou plusieurs composants, contacter un centre autorisé ou visiter le site [WWW.GESSI.COM](http://WWW.GESSI.COM)
- L'entretien du produit ne doit être effectué que par du personnel qualifié

### **MANUTENCIÓN**

- En el caso de que sea necesario reemplazar uno o más componentes, contacten con un revendedor autorizado o visiten el sitio [WWW.GESSI.COM](http://WWW.GESSI.COM)
- Encarguen sólo a personal calificado para el mantenimiento del producto



Fig. 22

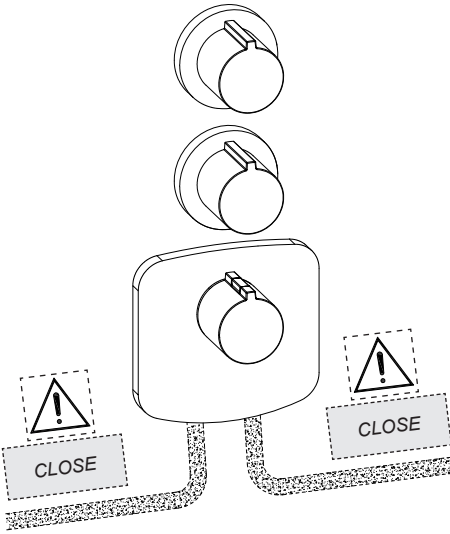

Fig. 23

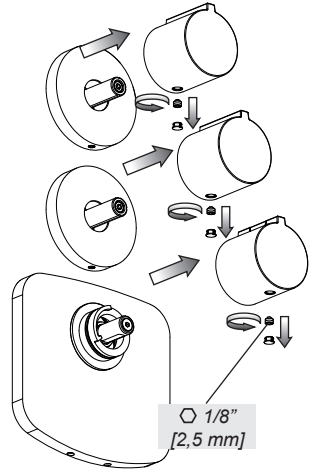

Fig. 24

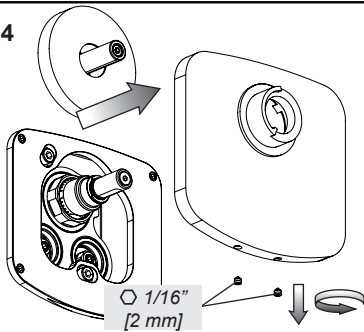

Fig. 26

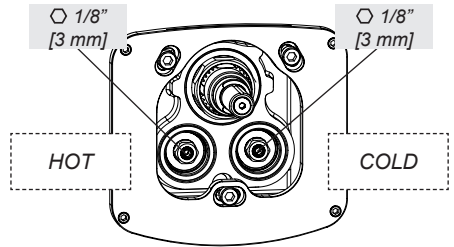
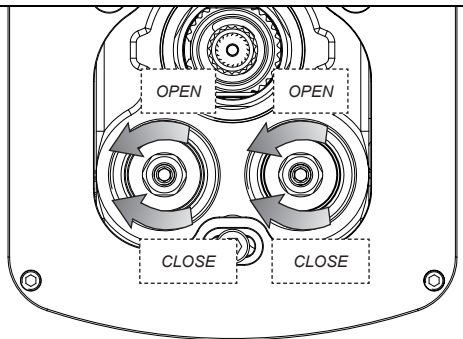
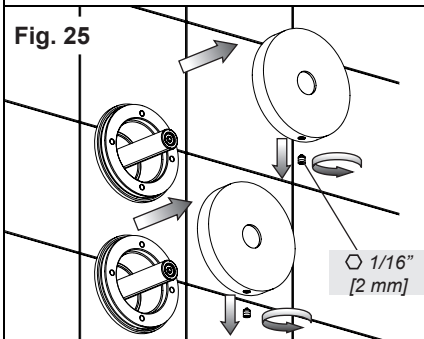

Fig. 25





HEADVALVE REPLACEMENT - SUBSTITUTION DE LA TÊTE - SUSTITUCIÓN DE LA MONTURA

Fig. 27

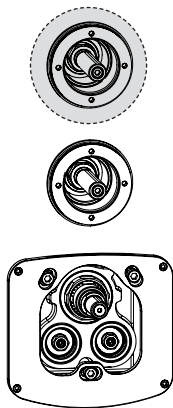

Fig. 28

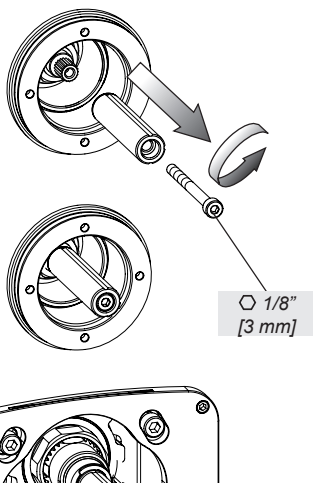
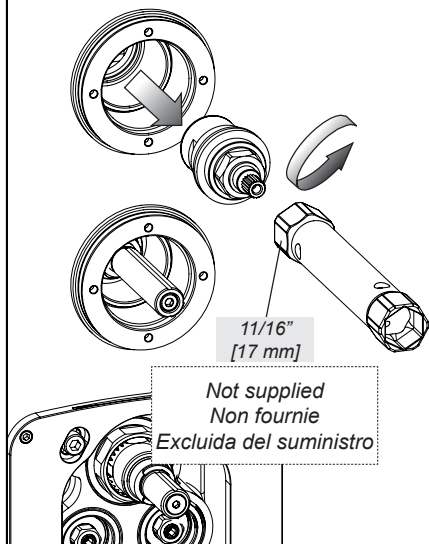

Fig. 29





ALIGNMENT OF CONTROL HANDLES - ALIENEMENT DES POIGNÉES DE COMMANDE -  
ALINEACIÓN DE LAS MANETAS DE MANDO

Fig. 30

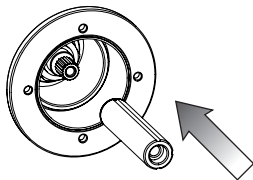

Fig. 31

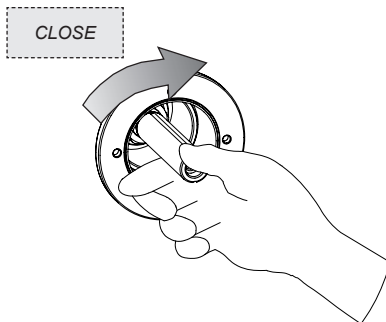

Fig. 32

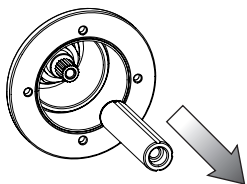

Fig. 33

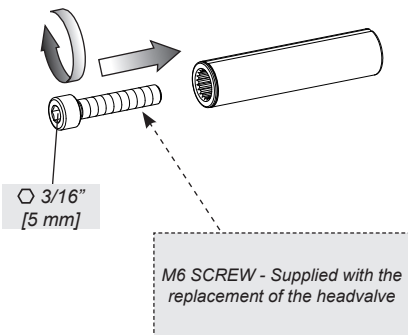

Fig. 34

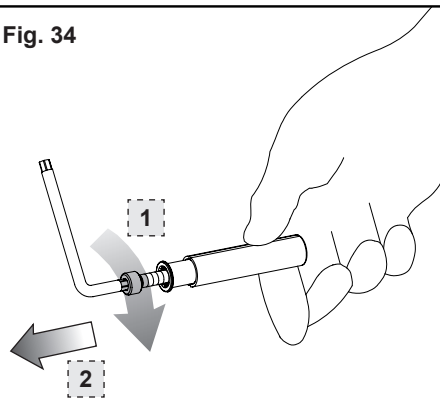
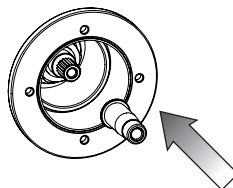

Fig. 35





ALIGNMENT OF CONTROL HANDLES - ALIENEMENT DES POIGNÉES DE COMMANDE -  
ALINEACIÓN DE LAS MANETAS DE MANDO

Fig. 36

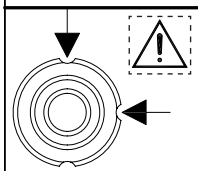
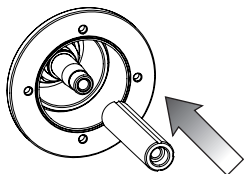
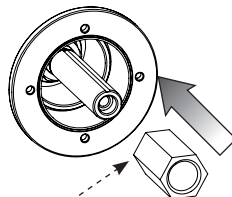

Fig. 37



Supplied with the replacement  
of the headvalve

Fig. 38

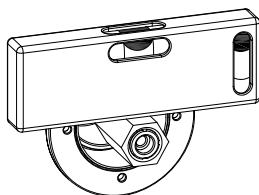

Fig. 39

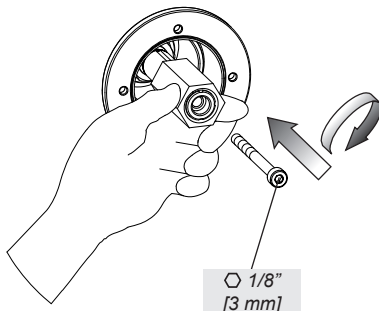

Fig. 40 - A

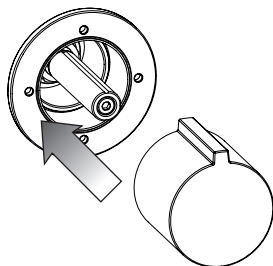
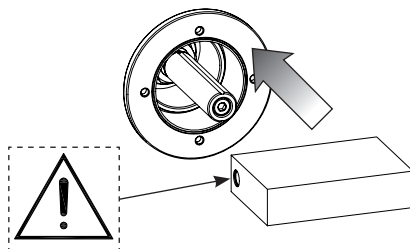

Fig. 40 - B





ALIGNMENT OF CONTROL HANDLES - ALIGNEMENT DES POIGNÉES DE COMMANDE -  
ALINEACIÓN DE LAS MANETAS DE MANDO

Fig. 41

OK

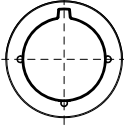

NO

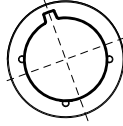

NO

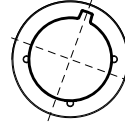

Repeat these steps until reaching proper alignment of the handle, and then remove it to allow the installation of external parts.

Repeat these steps until reaching proper alignment of the handle, and then remove it to allow the installation of external parts.

Repitan estas operaciones hasta obtener la correcta alineación de la maneta, finalmente remuévanla para permitir la instalación de las partes externas.



CARTRIDGE REPLACEMENT - SUBSTITUTION DE LA CARTOUCHE - SUSTITUCIÓN DEL CARTUCHO

Fig. 43

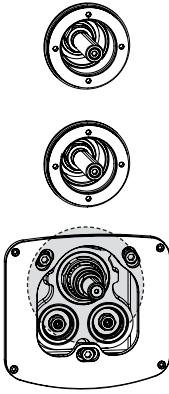

Fig. 44

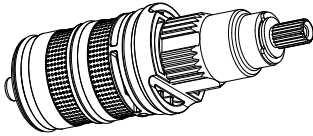
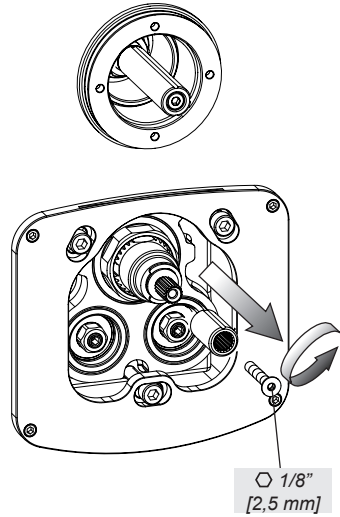

Fig. 45

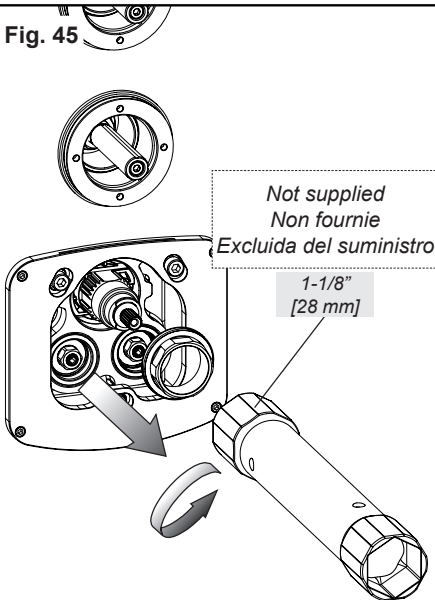
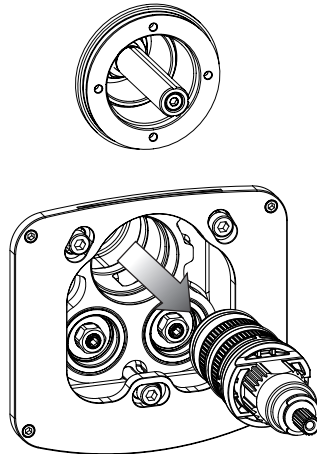

Fig. 46





INLET FILTERS CLEANING - NETTOYAGE DES FILTRES EN ENTRÉE -  
LIMPIEZA DE LOS FILTROS DE ENTRADA

Fig. 47

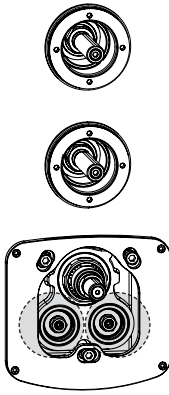

Fig. 48

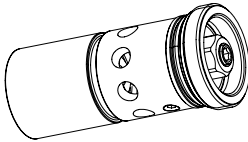
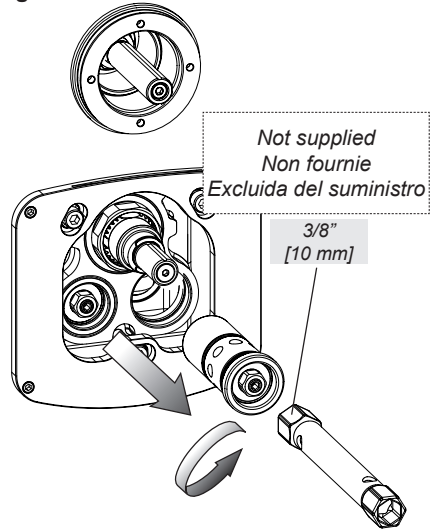

Fig. 49

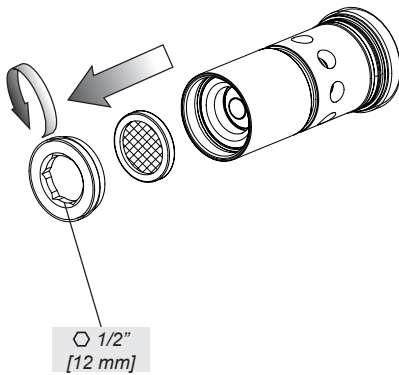

Fig. 50

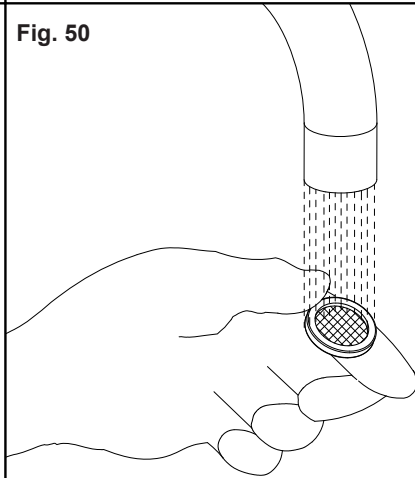



Fig. 51

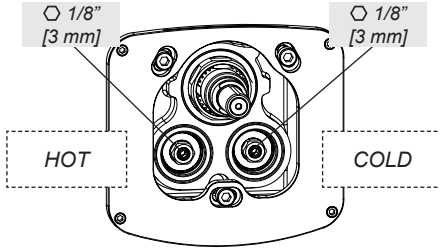

Fig. 52

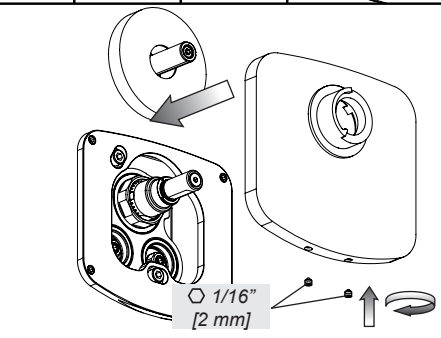
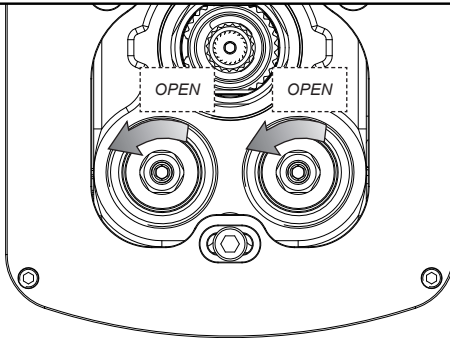
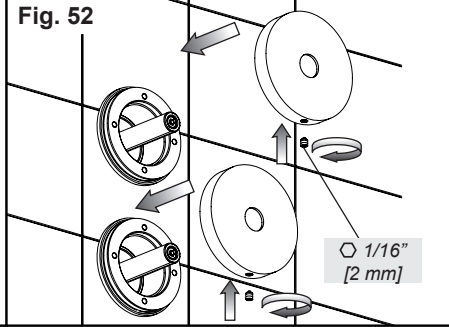

Fig. 53

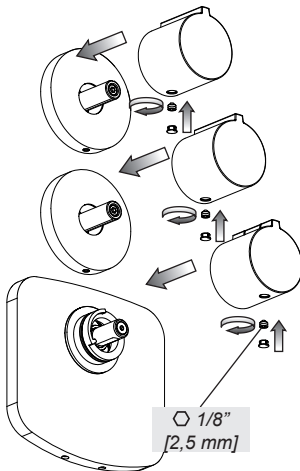

Fig. 54

