

1

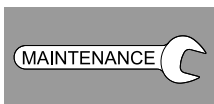

11 - 12



2 - 8

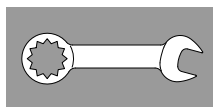

13

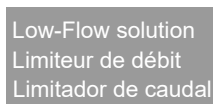

9 - 10



14





DIN 1053

DIN 18534

DIN 1988

DIN EN 806

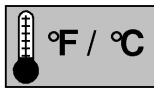
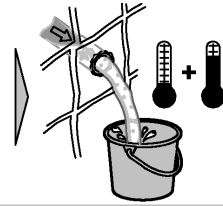

max. 158°F / 70°C

140°F / 60°C

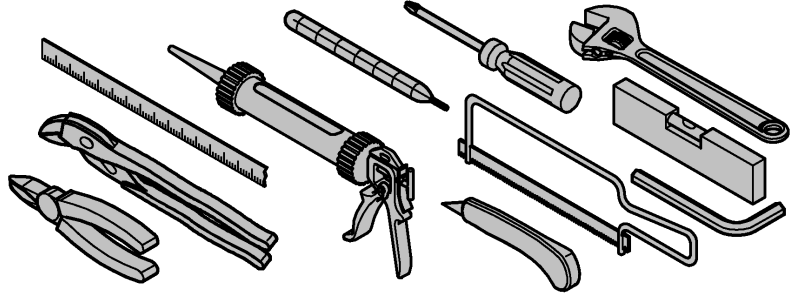

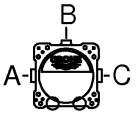
	bar						l/min
	1	2	3	4	5	6	
A	13,3	18,8	23	26,6	29,7	32,5	
B	15,6	22	27	31,2	34,9	38,2	
C	13,3	18,8	23	26,6	29,7	32,5	
A+B	19,1	26,9	33	38,1	42,6	46,7	
A+B+C	20,8	29,4	36	41,6	46,5	50,9	

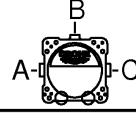
	psi						gpm
	14,5	29	43,5	58	72,5	87	
A	3,5	5	6,1	7	7,8	8,6	
B	4,1	5,8	7,1	8,2	9,2	10,1	
C	3,5	5	6,1	7	7,8	8,6	
A+B	5	7,1	8,7	10,1	11,3	12,3	
A+B+C	5,5	7,8	9,5	11	12,3	13,4	

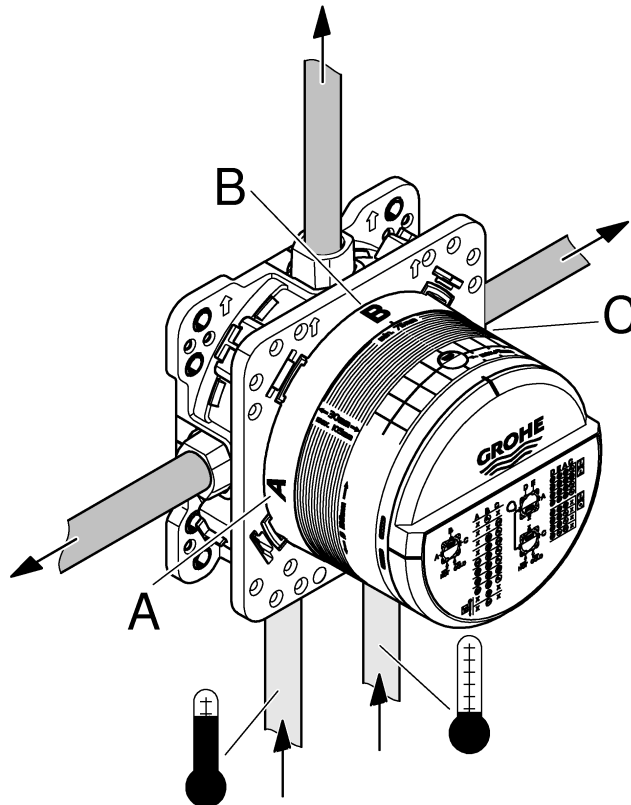



1

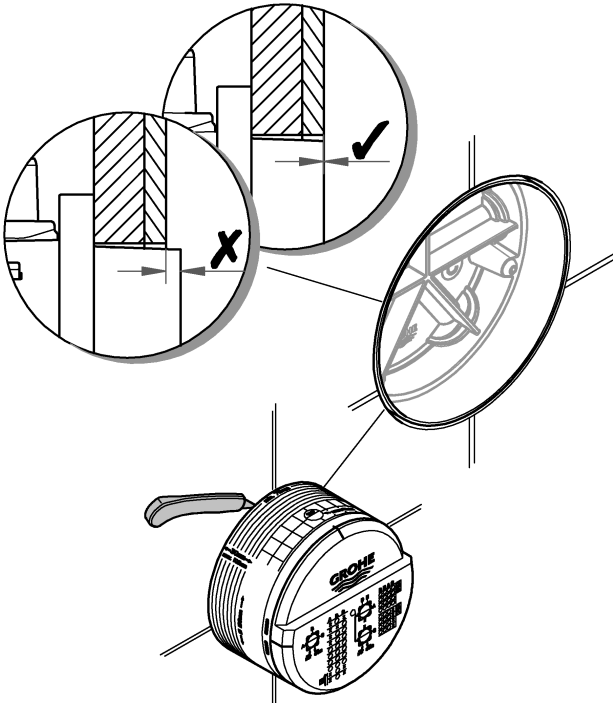
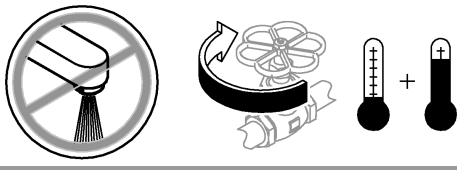

2

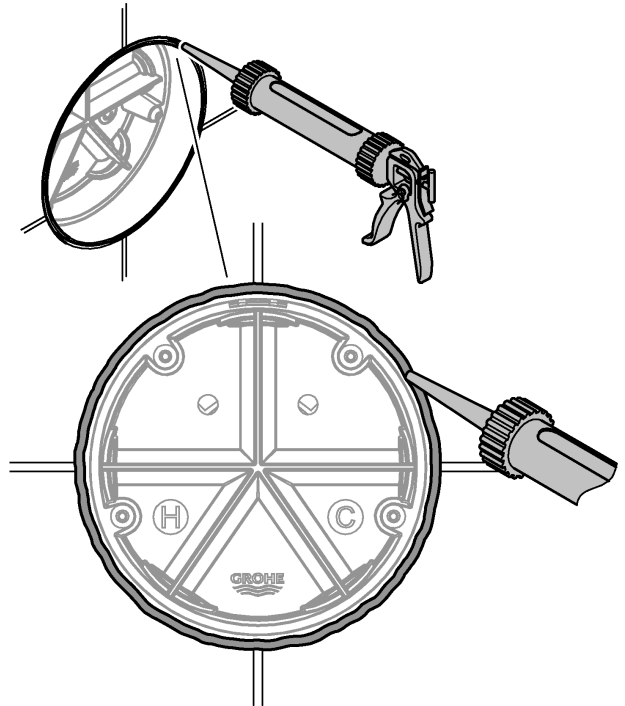

3

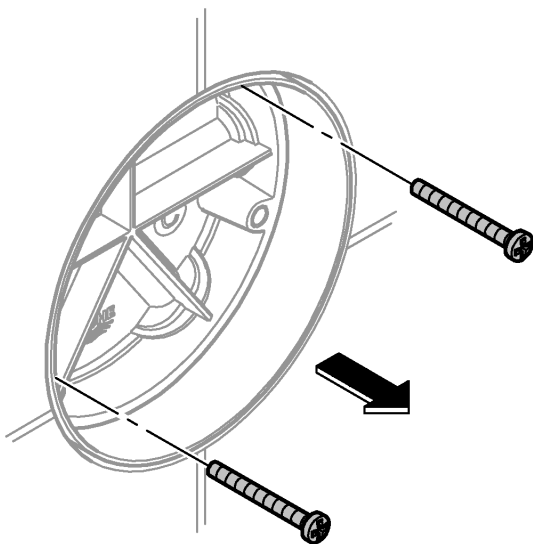

4

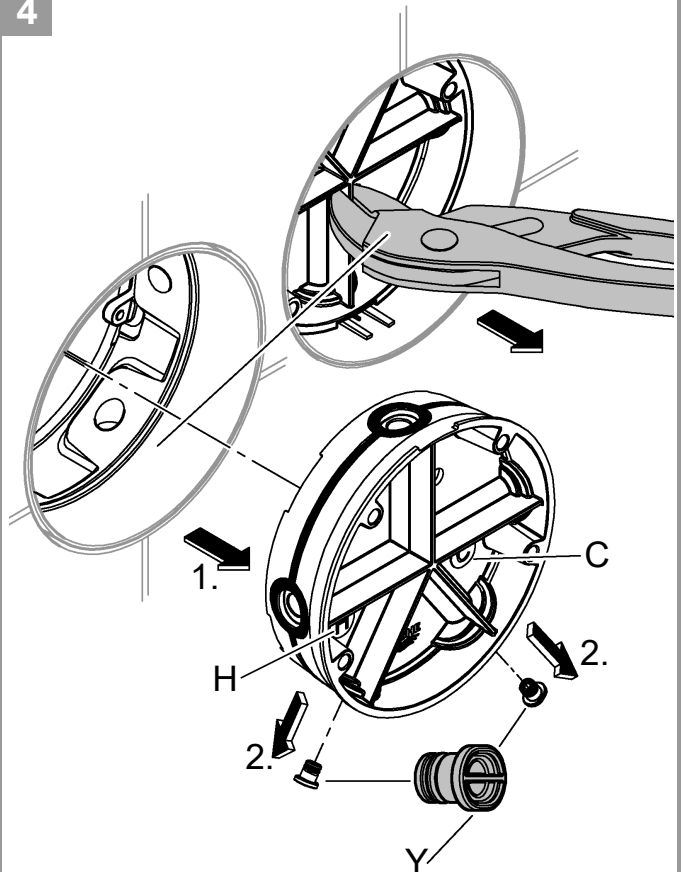



5

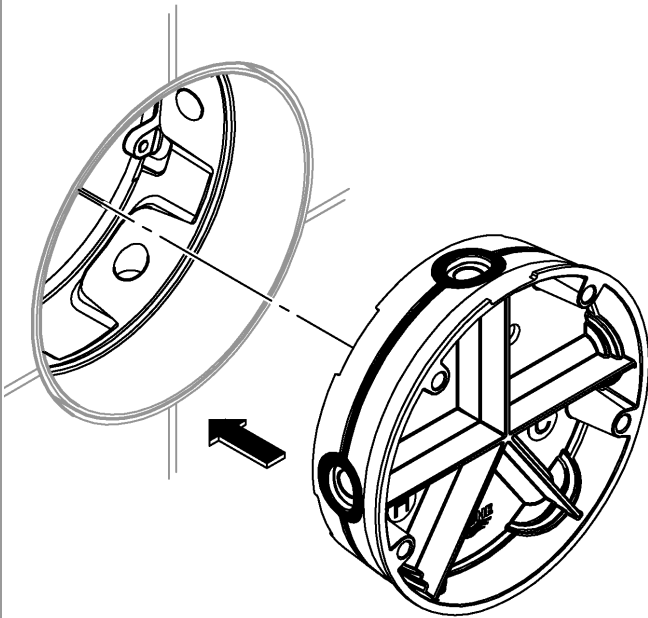

6

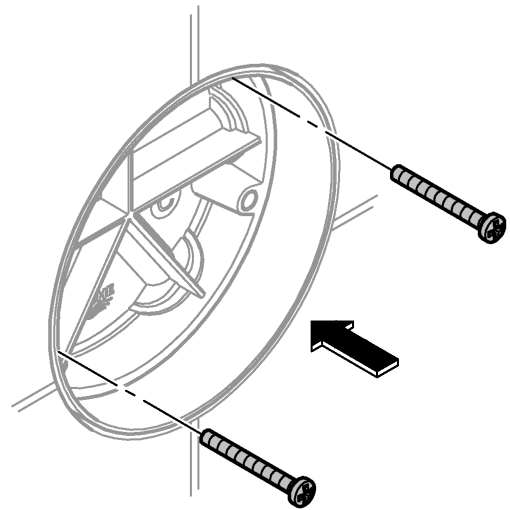

7

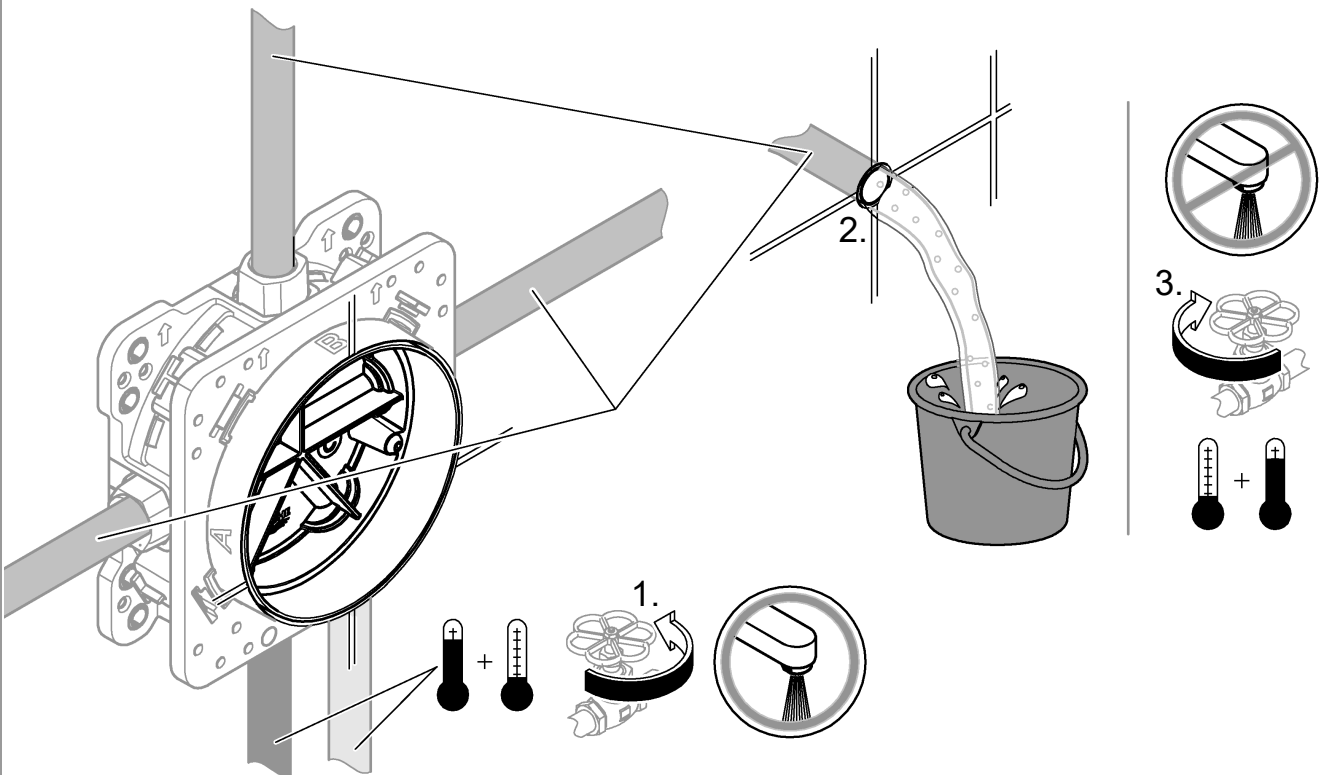

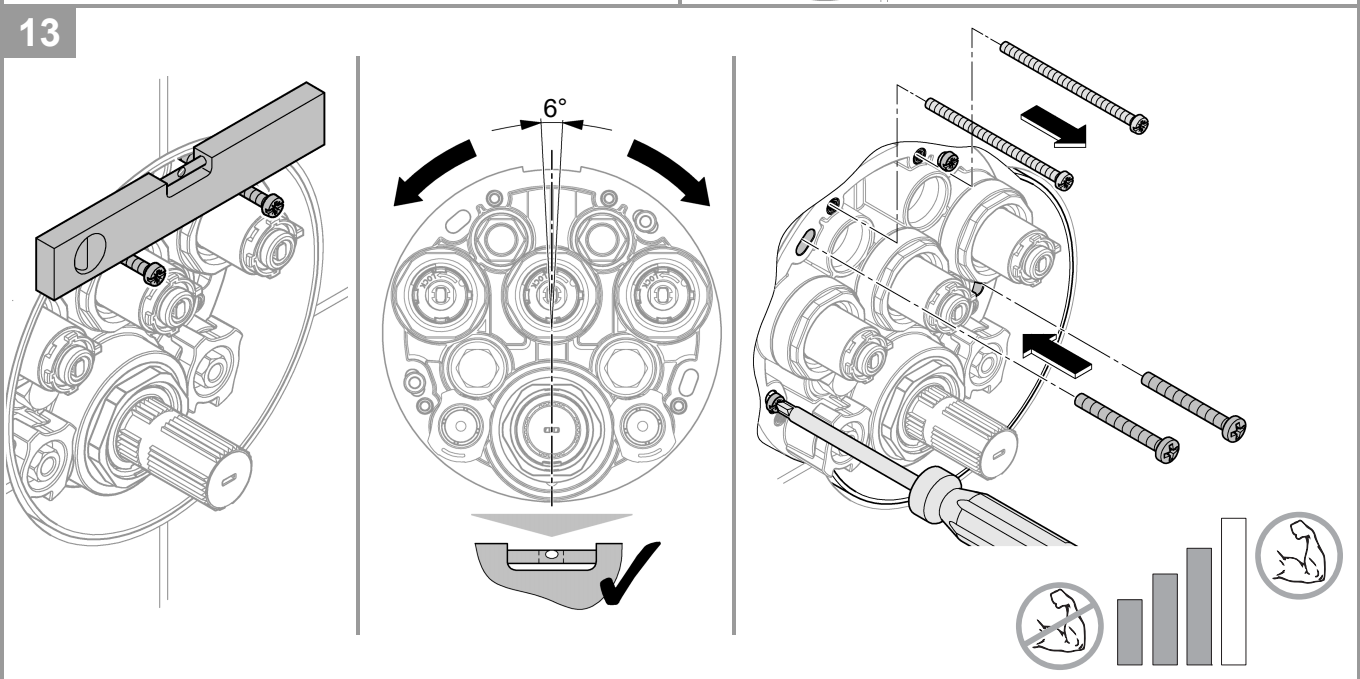
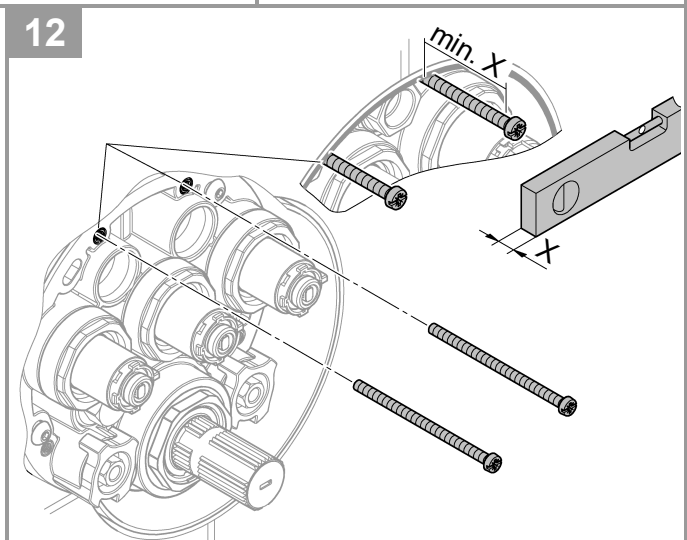
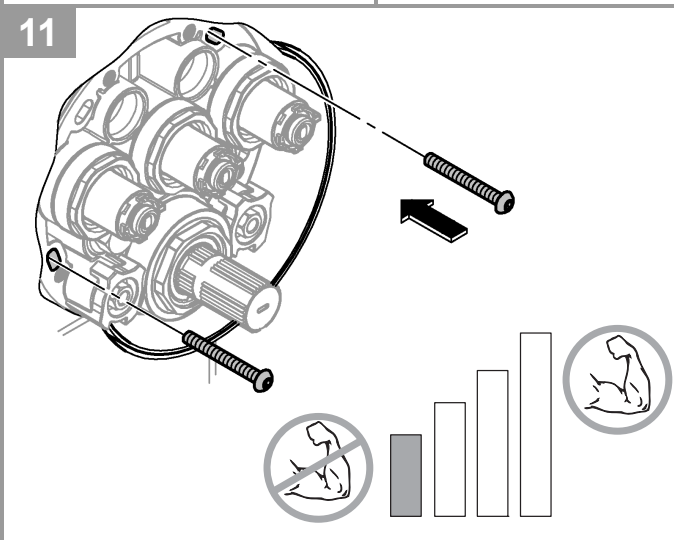
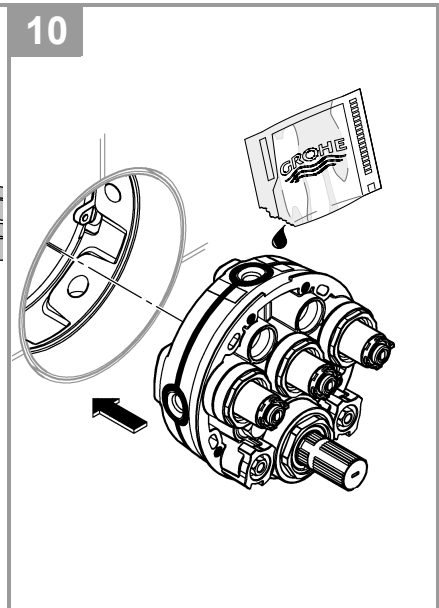
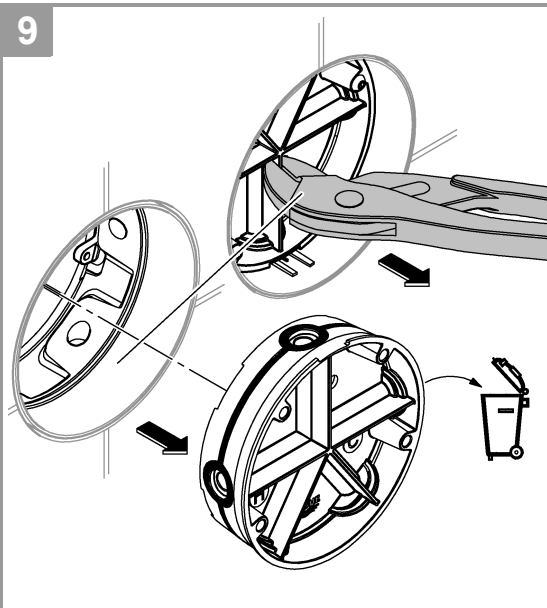
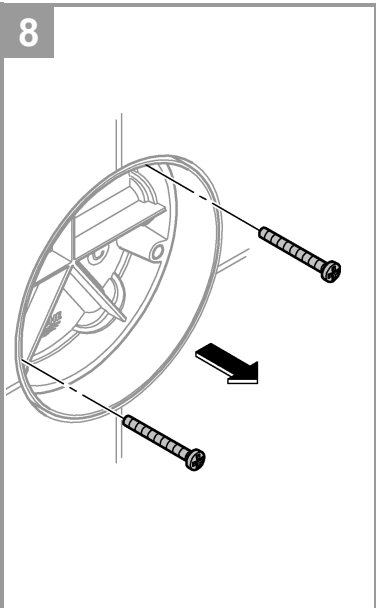



14

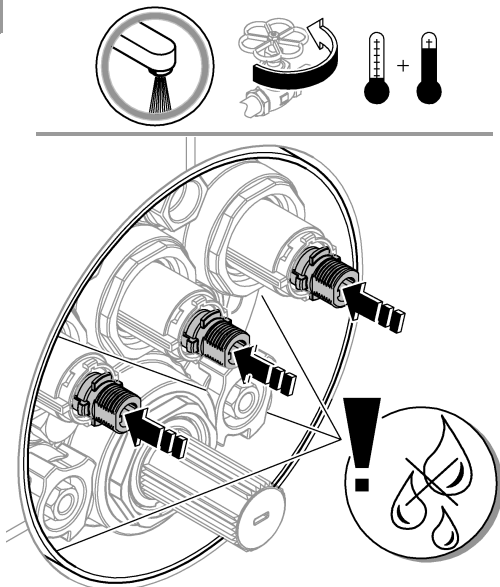

15

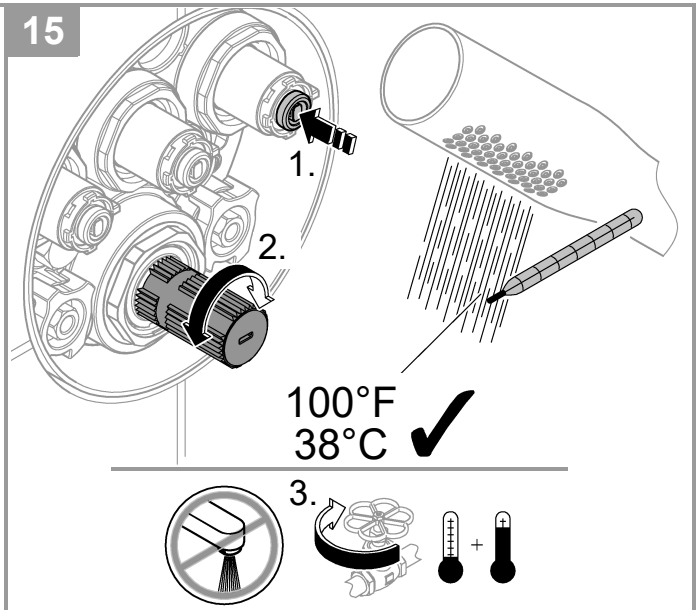

16

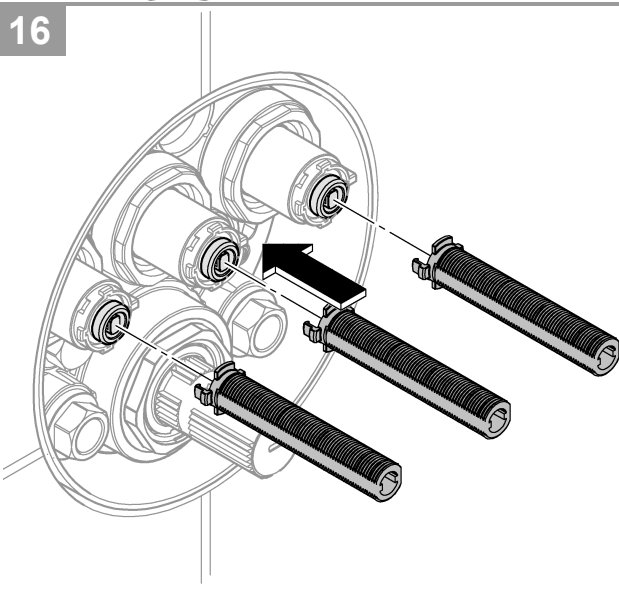

17

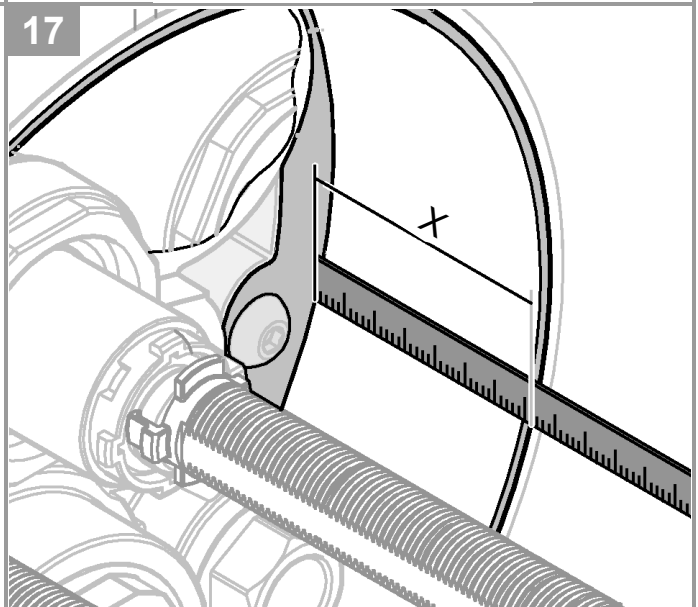

18

A
 $X < 1\frac{3}{4}"$
(40mm)

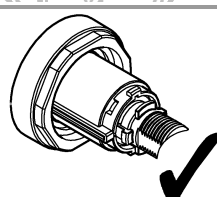
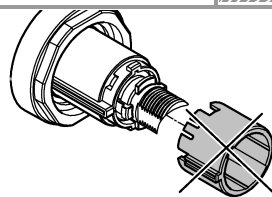

B
 $X = 1\frac{3}{4}" - 2\frac{3}{16}"$
(40mm - 55mm)

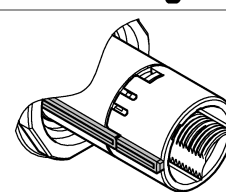
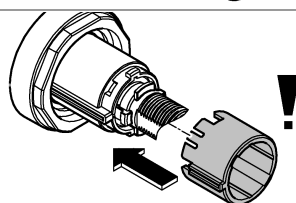

C
 $X > 2\frac{3}{16}"$
(55mm)

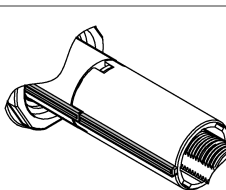
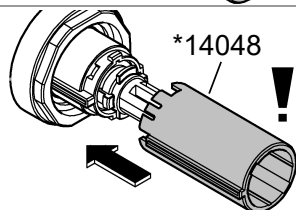



19

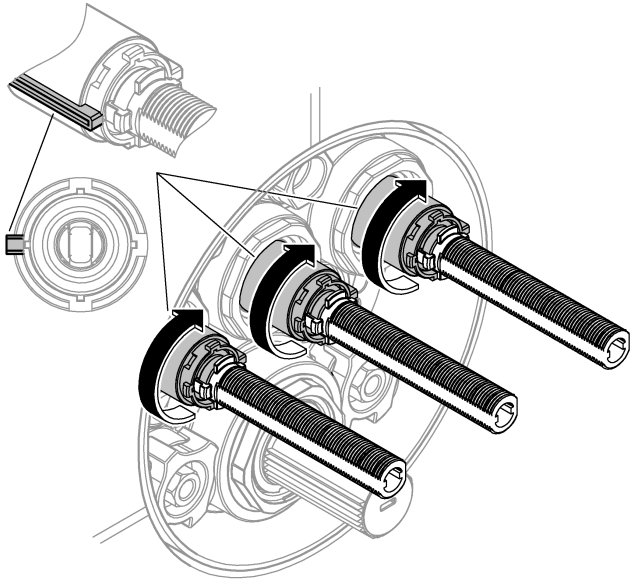

20

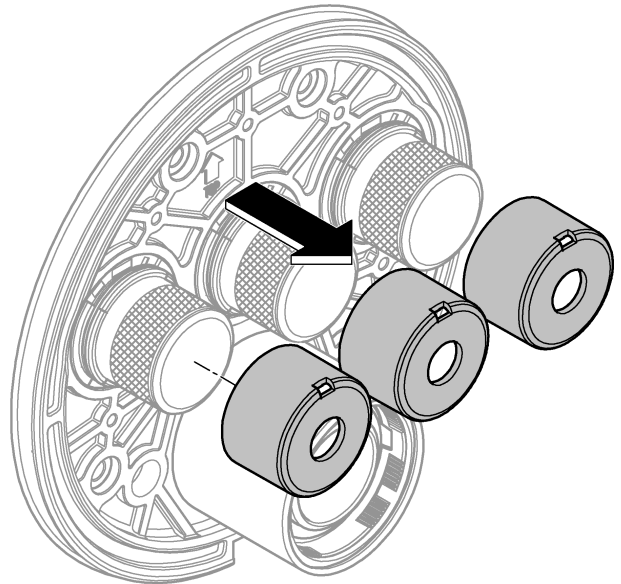

21

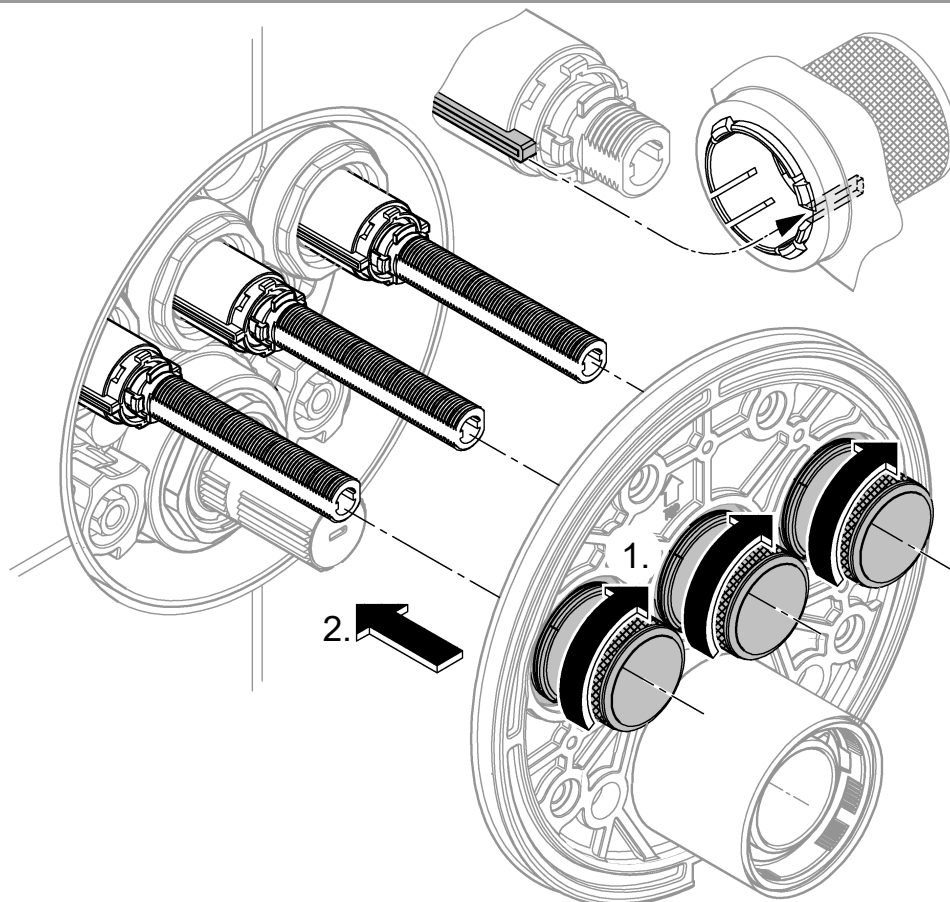



22

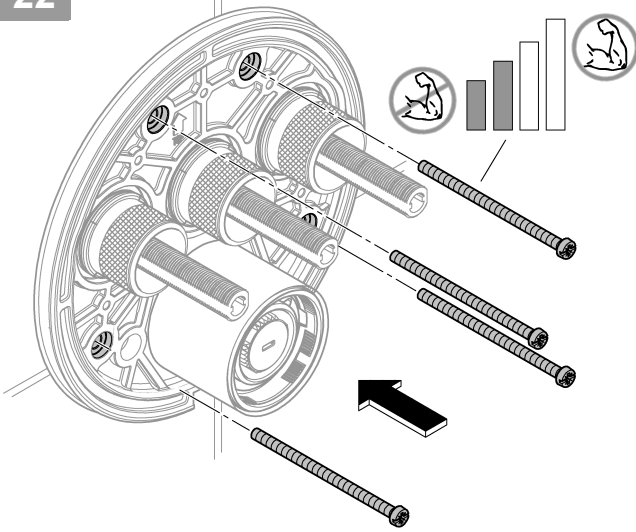

23

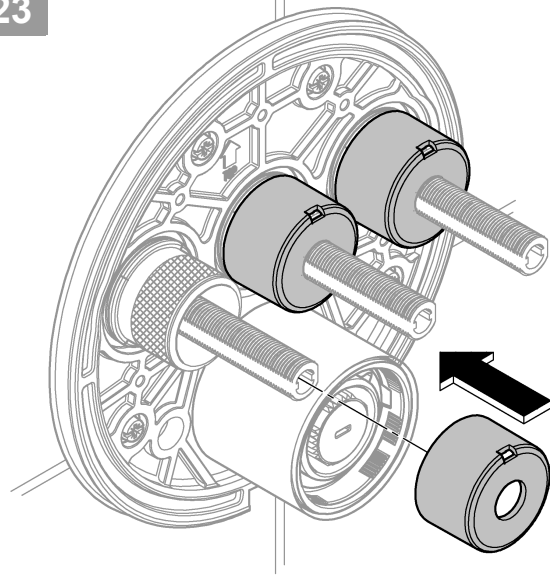

24

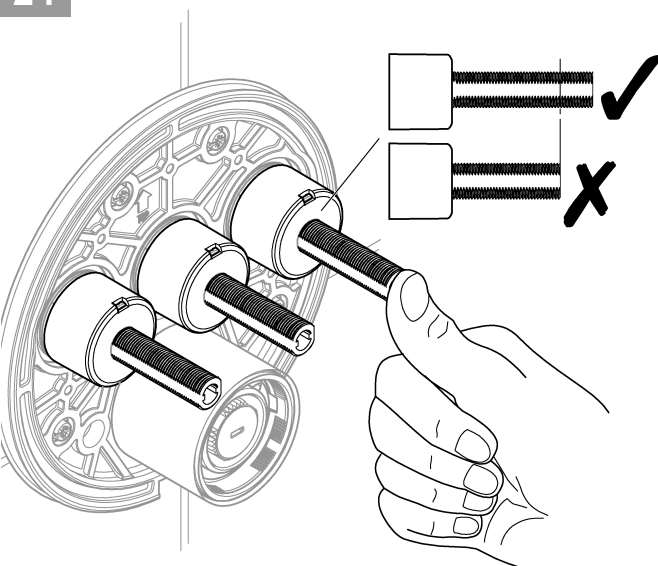

25

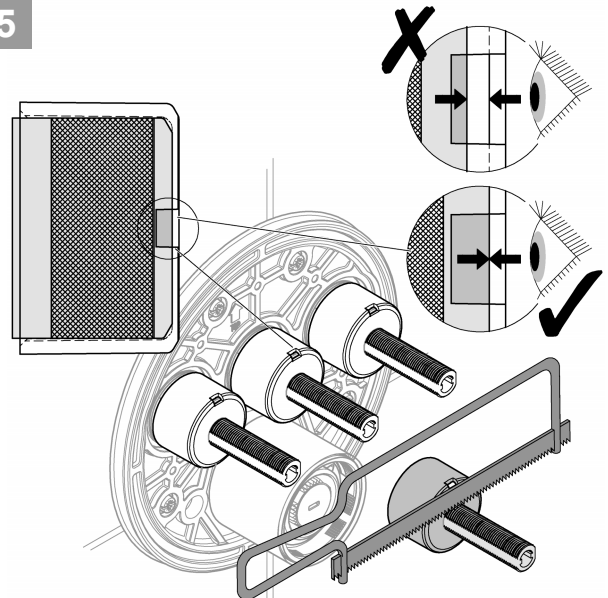

26

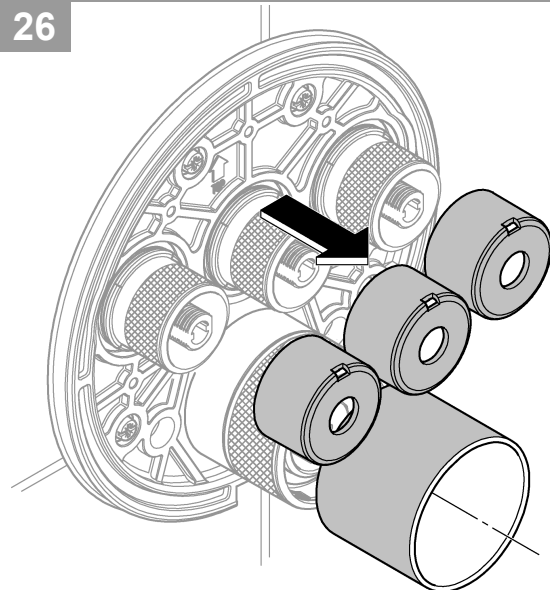

27

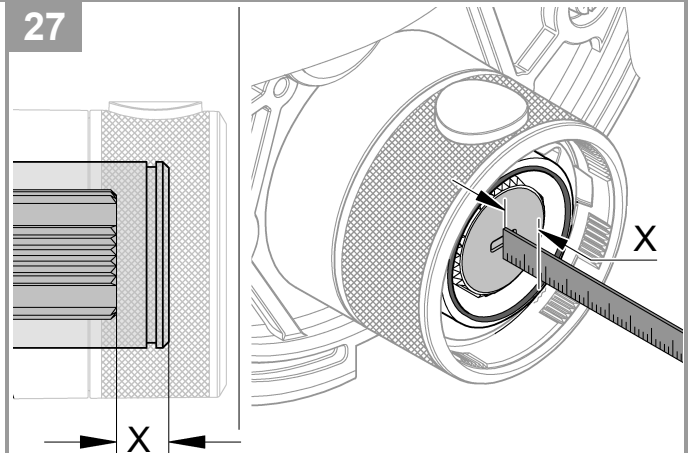

$X < 1\frac{3}{16}$ "
(29,5)

28

$X > 1\frac{3}{16}$ "
(29,5) *14 048



28

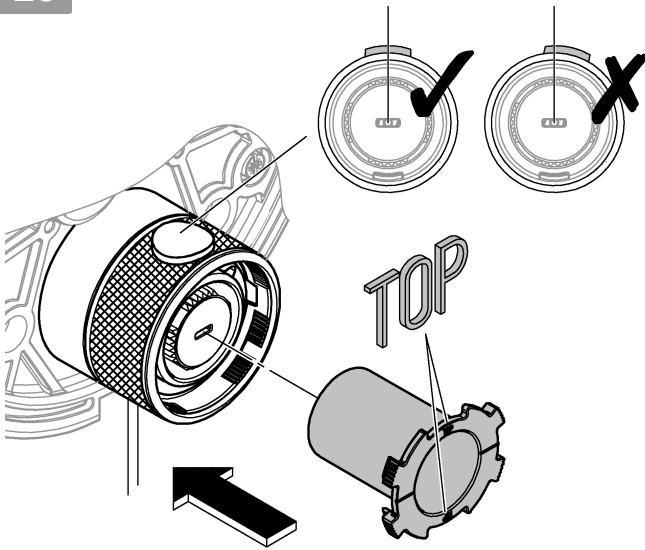

29

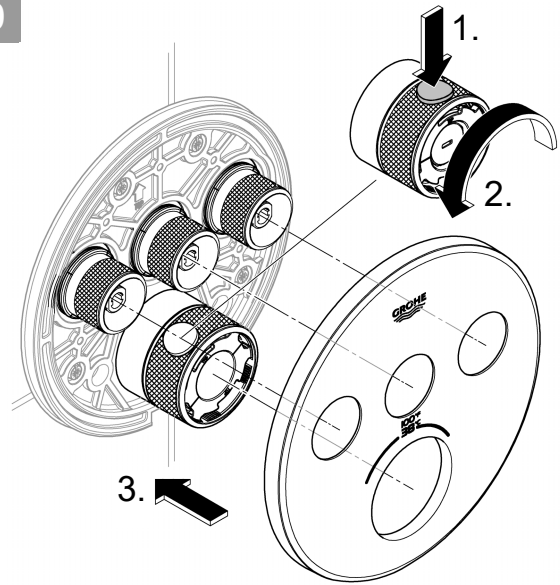

30

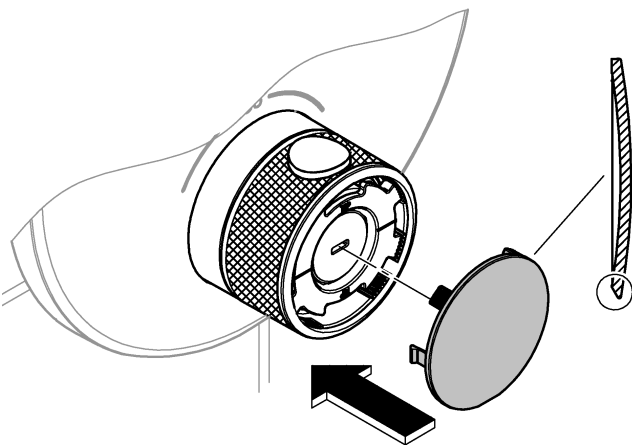

31

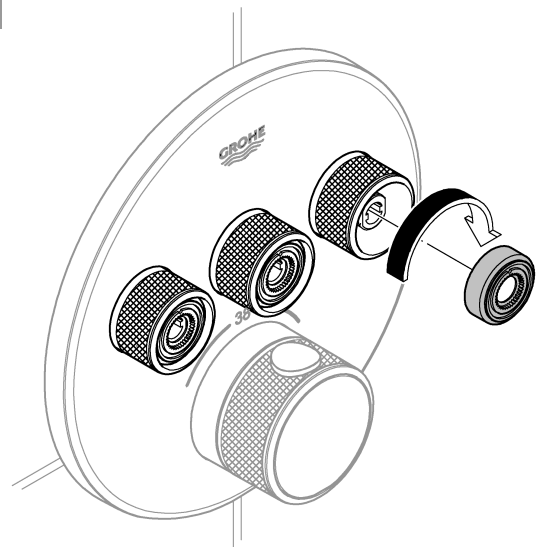

32

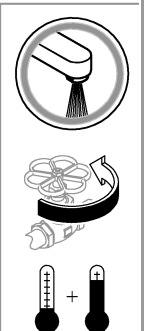
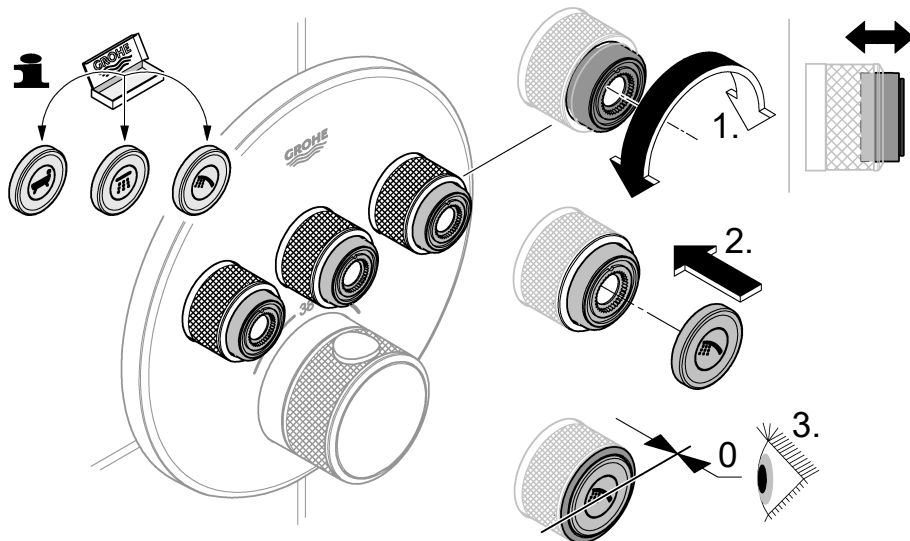

Note

Please know and follow all applicable local plumbing codes when setting the temperature on the water heater.

Only for shower application:

If your local plumbing code requires to install the limiter to reduce the total flow of water in the shower to 1.8gpm at 80psi, see page 11.

Technical Data

- Flow pressure
- Minimum flow pressure without downstream resistances 7.25 psi
- Minimum flow pressure with downstream resistances 14.5 psi
- Recommended 21.75–72.5 psi
- Temperature
- Hot water supply max. 158 °F
- Recommended for energy saving 140 °F
- Thermal disinfection possible
- Hot water temperature at supply connection min. 3.6 °F higher than mixed water temperature

Flow rates without downstream resistances, see page 1.

These should be observed when dimensioning the outlet!

The following special accessories are available:

- Extension 1" (25mm) (prod. no.: 14 048)

Thermostat compact cartridge for exchanged water channels: Reversed connections, hot on right and cold on left, replace compact cartridge (prod. no.: 49 003)

Installation

- In order to flush, remove the plugs (Y), see page 2 Fig. [4].
- Open cold and hot water supply and check connections for watertightness!
- Alignment of functional unit by 6° possible.
- Measure valves, see page 5 Fig. [18]. For a dimension larger than $1\frac{1}{16}$ " (18mm), the enclosed extension must be used.

Adjusting to 100 °F

- Before the mixer is put into service if the mixed water temperature measured at the point of discharge varies from the desired temperature set on the thermostat, see page 6 Fig. [20].
- Every time following maintenance on the thermostatic compact cartridge.

Temperature limitation

The safety stop limits the temperature range to 100 °F. If a higher temperature is required, the 100 °F stop can be overridden by pressing the button.

In accordance with local plumbing codes, this thermostat is limited to a maximum temperature of 109 °F.

Danger of frost damage

When the domestic water system is drained, the thermostats must be drained separately since non-return valves are installed in the hot and cold water connections.

Remarque

Vous devez connaître et respecter tous les codes de plomberie locaux applicables pour le réglage de la température du chauffe-eau.

Seulement pour l'application de douche:

Si votre code de plomberie exige, installez le limiteur de débit pour réduire le débit total de l'eau dans la douche à 6,8 l/min à 5,5 bar, voir page 11.

Caractéristiques techniques

- Pression dynamique
- Pression dynamique minimale sans résistances en aval 0,5 bar
- Pression dynamique minimale avec résistances en aval 1 bar
- Recommandée 1,5 à 5 bars
- Débit minimal 5 l/min
- Température
- Entrée d'eau chaude max. 70 °C
- Recommandée pour économie d'énergie 60 °C
- Désinfection thermique possible
- Température de l'eau chaude au raccord d'alimentation au moins 2 °C supérieure à la température de l'eau mitigée

Débits sans résistances en aval, voir page 1. **Respecter les données indiquées lors du dimensionnement de l'évacuation !**

Les accessoires spéciaux suivants sont disponibles :

- Extension de 25mm (réf. : 14 048)

Cartouche compacte de thermostatique pour raccordements inversés : Raccordements inversés (chaud à droite, froid à gauche), remplacer la cartouche compacte (réf. : 49 003)

Installation

- Pour le rinçage, démonter les clapets (Y), voir page 2, fig. [4].
- Ouvrir les arrivées d'eau froide et d'eau chaude et vérifier l'étanchéité des raccordements.
- Possibilité d'orienter l'unité de commande de 6°.
- Mesurer les vannes, voir page 5, fig. [18]. Pour des dimensions supérieures à 18mm, utiliser l'extension fournie.

Réglage sur 38 °C

- Préalablement à la mise en service : si la température de l'eau mitigée mesurée au point de puisage est différente de la température souhaitée réglée au niveau de la poignée graduée du thermostatique, voir page 6, fig. [20].
- Après chaque opération de maintenance sur la cartouche compacte du thermostatique.

Limitation de la température

La température est limitée à 38 °C par la butée de sécurité. Il est possible d'obtenir une température plus élevée (supérieure à 38 °C) en appuyant sur le bouton.

Conformément aux directives locales d'installation, ce thermostatique est limité à une température max. de 43 °C.

Attention en cas de risque de gel

Lors du vidage de l'installation sanitaire, il convient de vider séparément les thermostats dont les raccordements d'eau froide et d'eau chaude sont équipés de clapets anti-retour.

Nota

Debe conocer y cumplir todos los códigos locales aplicables para ajustar la temperatura del calentador de agua.

Solo para la aplicación de ducha:

Si el código de instalación local requiere, instale el limitador de caudal para reducir el caudal total de agua en la ducha a 1.8gpm a 80psi, véase la página 11.

Datos técnicos

- Presión de trabajo
- Presión mínima de trabajo sin resistencias postacopladas 7.25 psi
- Presión mínima de trabajo con resistencias postacoplada 14.5 psi
- Recomendado 21.75-72.5 psi
- Caudal mínimo 1.3 gpm
- Temperatura
- Entrada de agua caliente máx. 158 °F
- Recomendado para ahorrar energía 140 °F
- Desinfección térmica posible
- La temperatura del agua caliente en la acometida de mín. 3.6 °F es superior a la temperatura del agua mezclada

Caudales sin resistencias postacopladas, véase la página 1.

Tenga en cuenta las dimensiones del desagüe.

Los siguientes accesorios especiales están disponibles:

- Prolongación de 1" (25mm) (n.º de pedido: 14 048)

Cartuchos compactos de termostato para las entradas de agua intercambiadas: Conexión invertida, sustituir los cartuchos compactos, los calientes en el lado derecho y los fríos en el izquierdo (n.º de pedido: 49 003)

Instalación

- Para lavar, desmonte el tapón (Y), véase la página 2 fig. [4].
- Abrir las llaves de paso del agua fría y del agua caliente y comprobar la estanqueidad de las conexiones.
- Es posible alinear la unidad de funcionamiento 6°.
- Medir las válvulas, véase la página 5 fig. [18]. Para una medida más grande de $1\frac{1}{16}$ " (18mm), se debe utilizar la prolongación suministrada.

Ajustar a 100 °F

- Antes de la puesta en servicio, si la temperatura del agua mezclada medida en el punto de consumo difiere de la temperatura teórica ajustada en el termostato, véase la página 6 fig. [20].
- Después de cada operación de mantenimiento en el cartucho compacto del termostato.

Limitación de la temperatura

La gama de temperaturas está limitada a 100 °F mediante el cierre de seguridad. Si desea seleccionar una temperatura más alta, se puede exceder el límite de 100 °F presionando la tecla.

En las normas de instalación locales el termostato tiene una temperatura máxima establecida de 109 °F.

Atención en caso de peligro de helada

Al vaciar la instalación de la casa, los termostatos deberán vaciarse por separado, ya que hay válvulas antirretorno en las conexiones del agua fría y caliente.

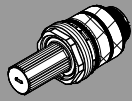

MAINTENANCE 

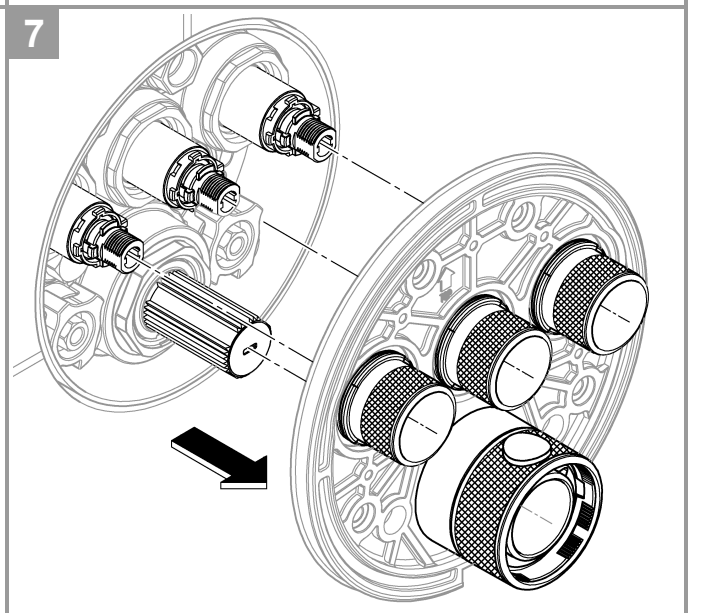
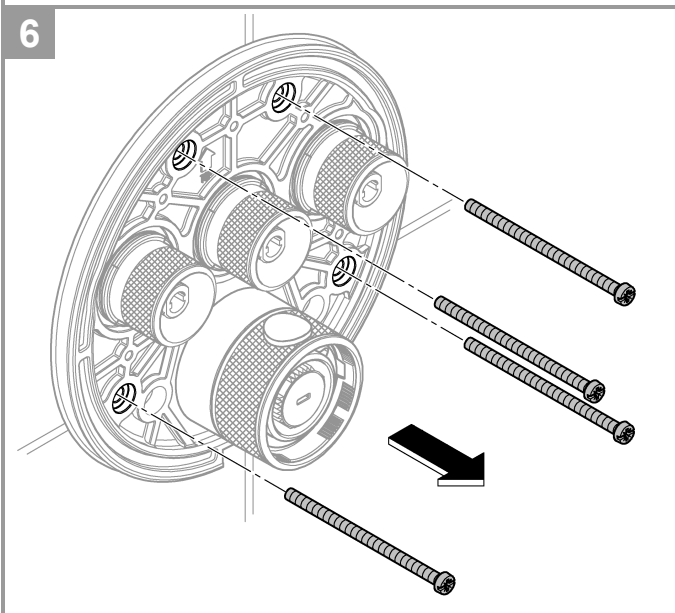
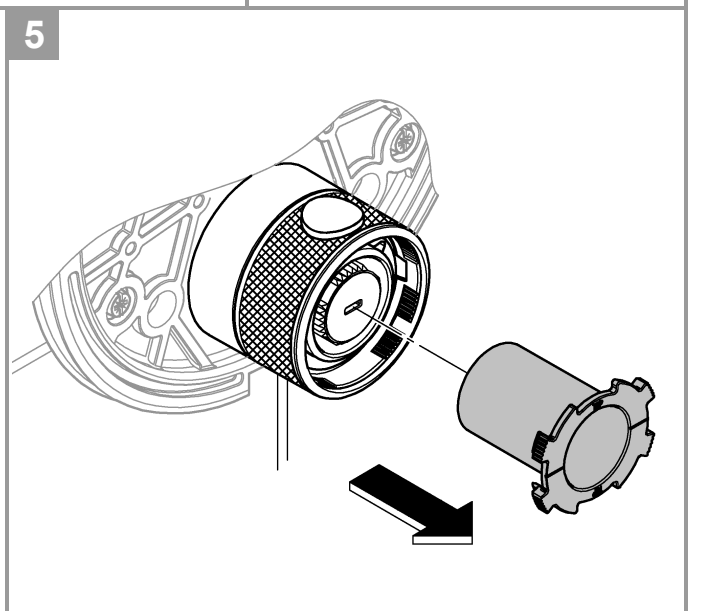
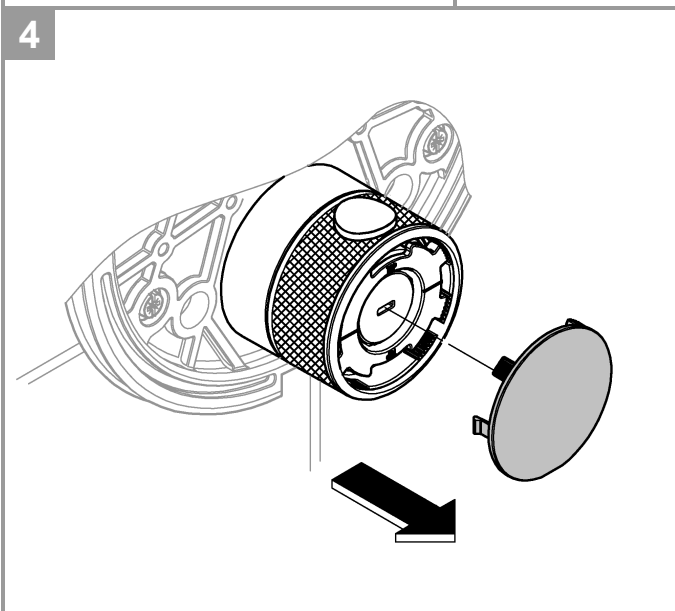
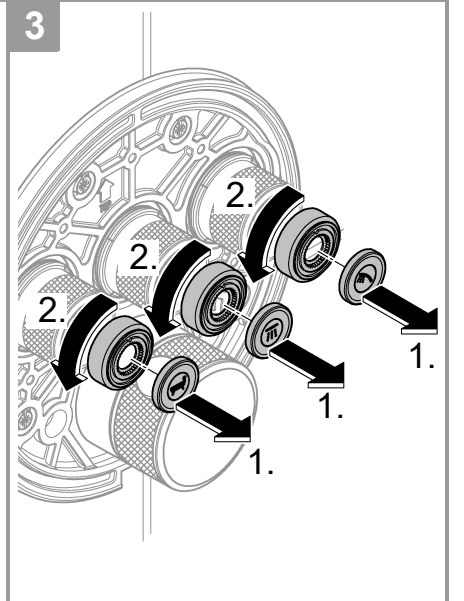
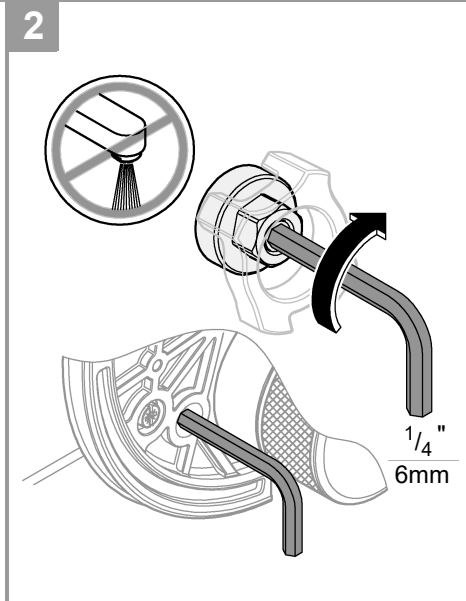
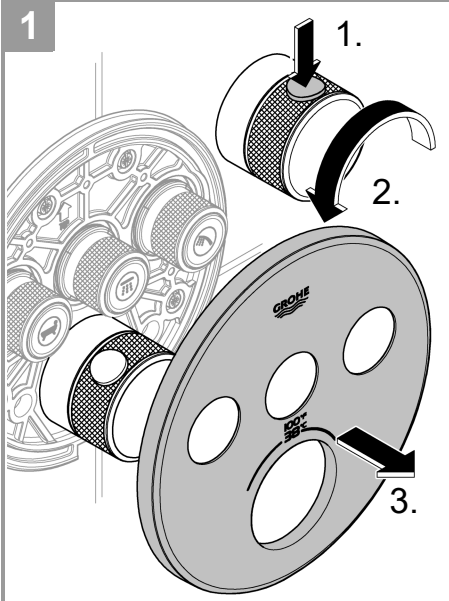

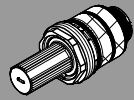

MAINTENANCE



8a

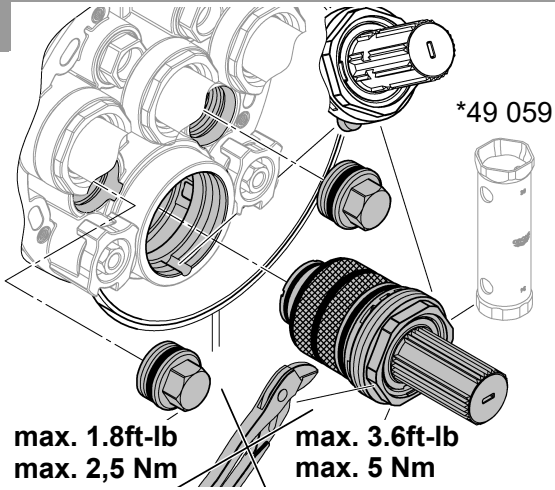

9a

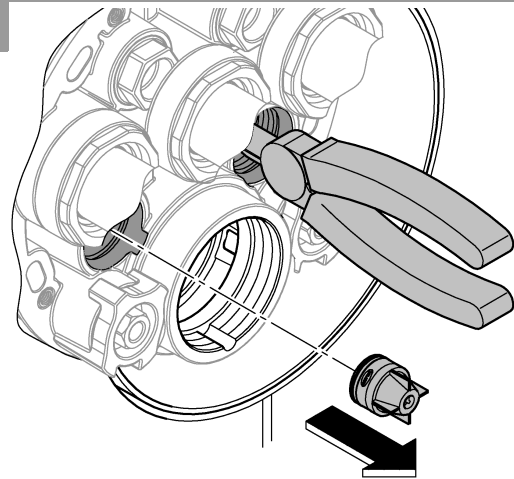

10a

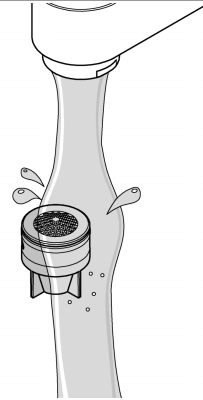
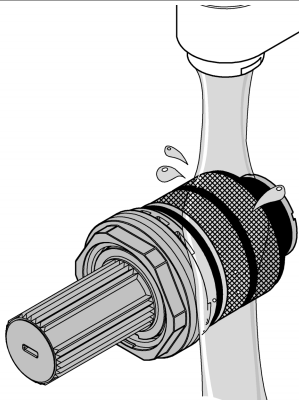

MAINTENANCE

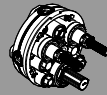

8b

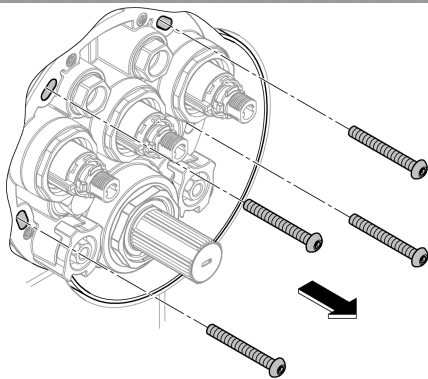

9b

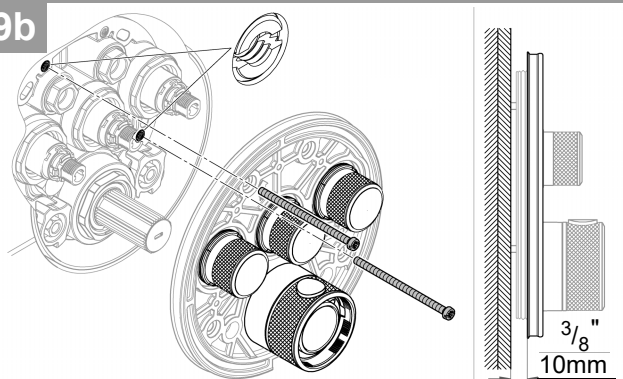

10b

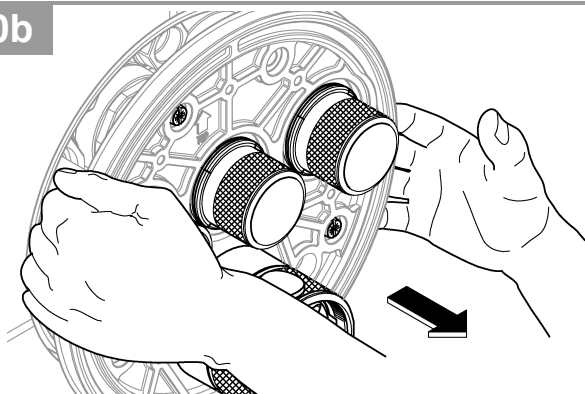

11b

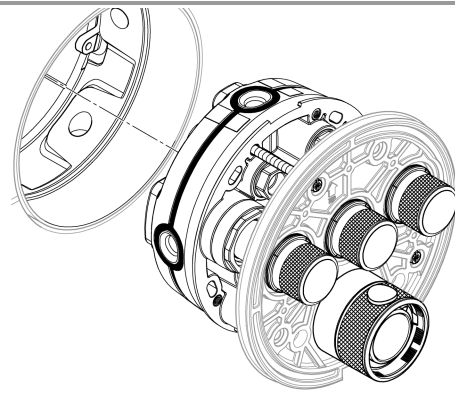

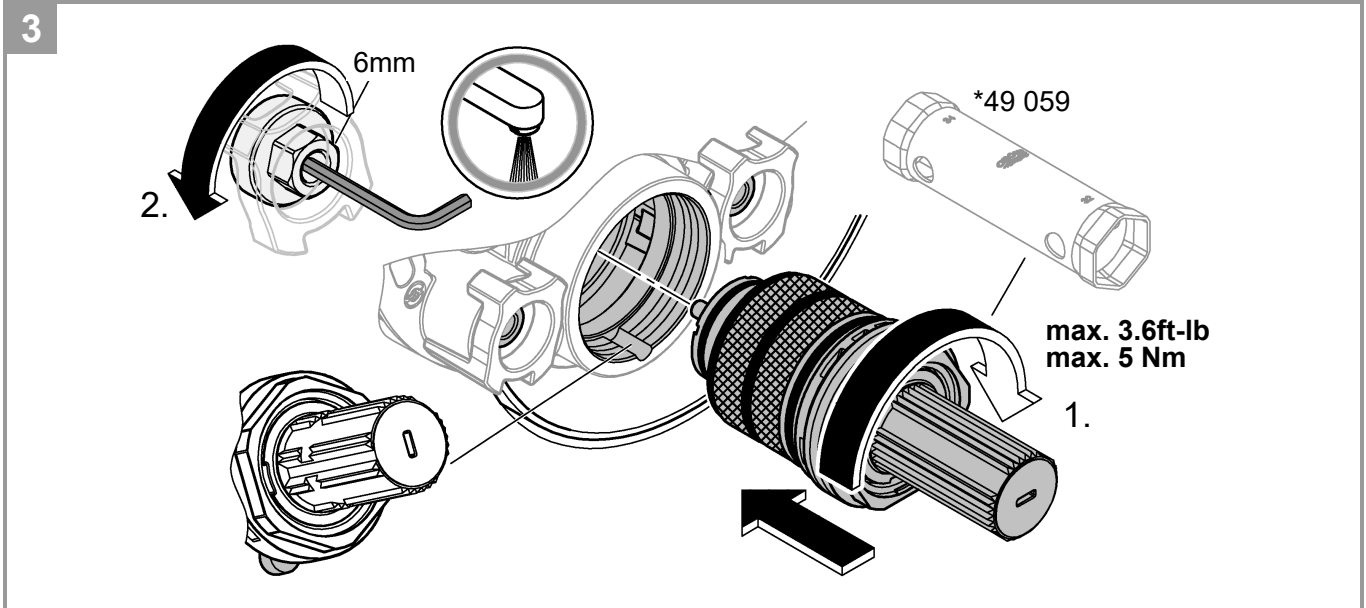
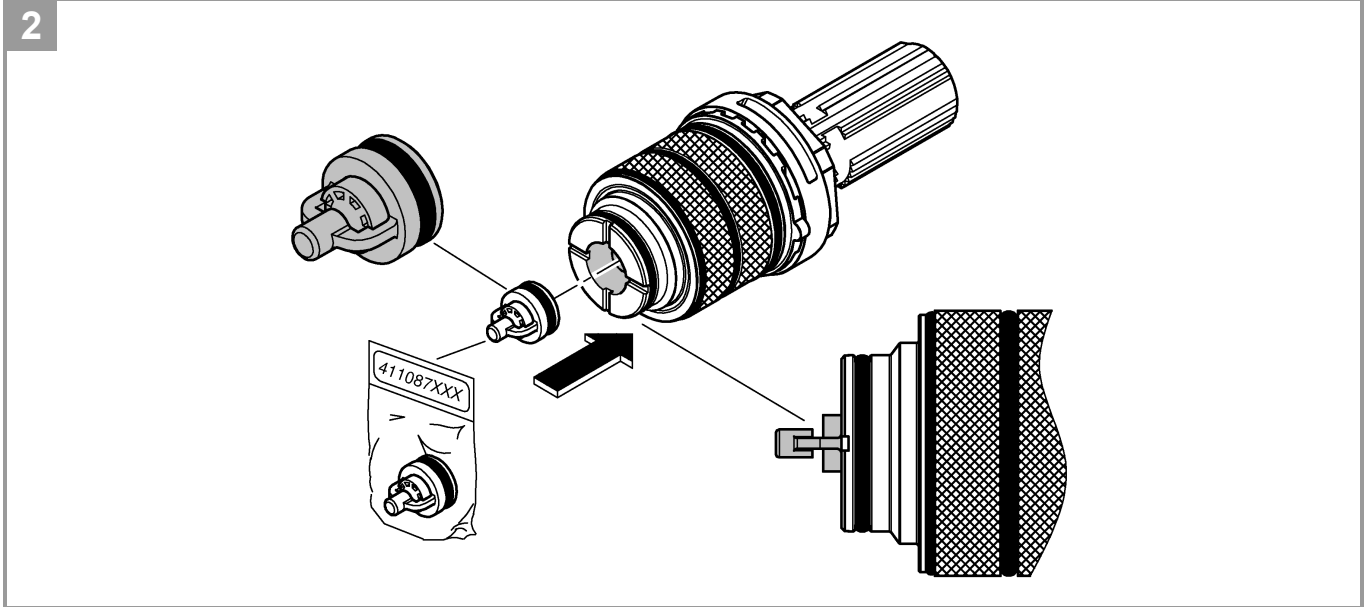
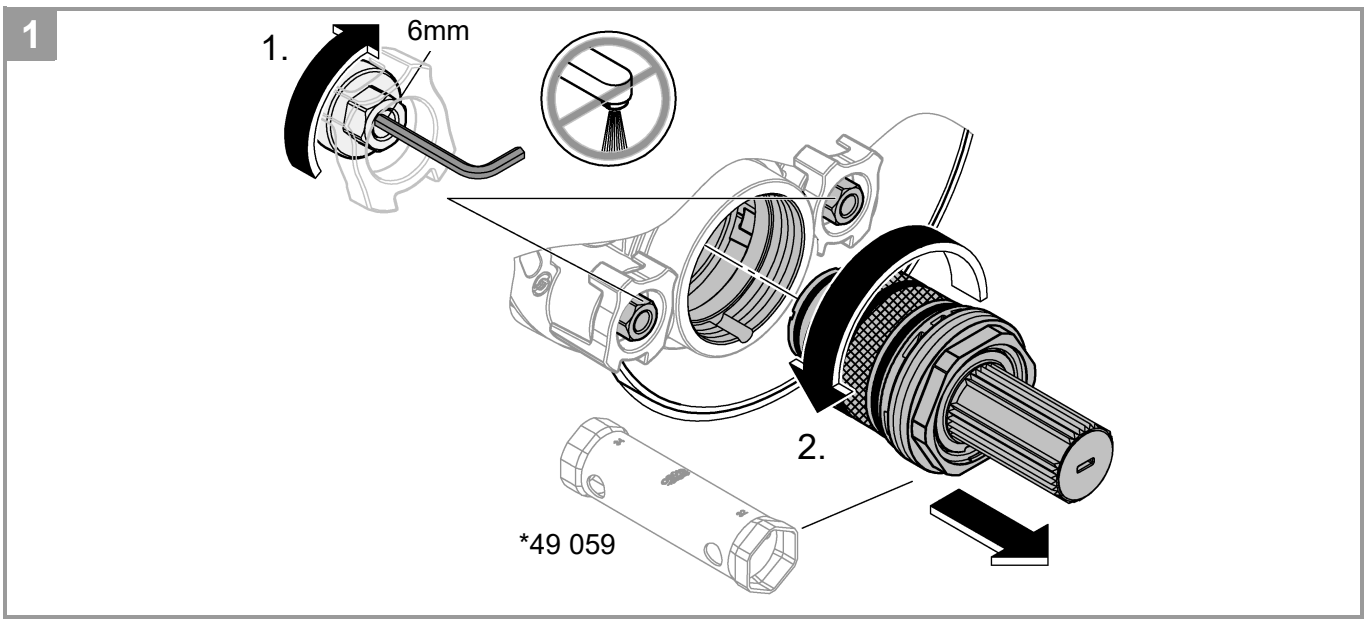

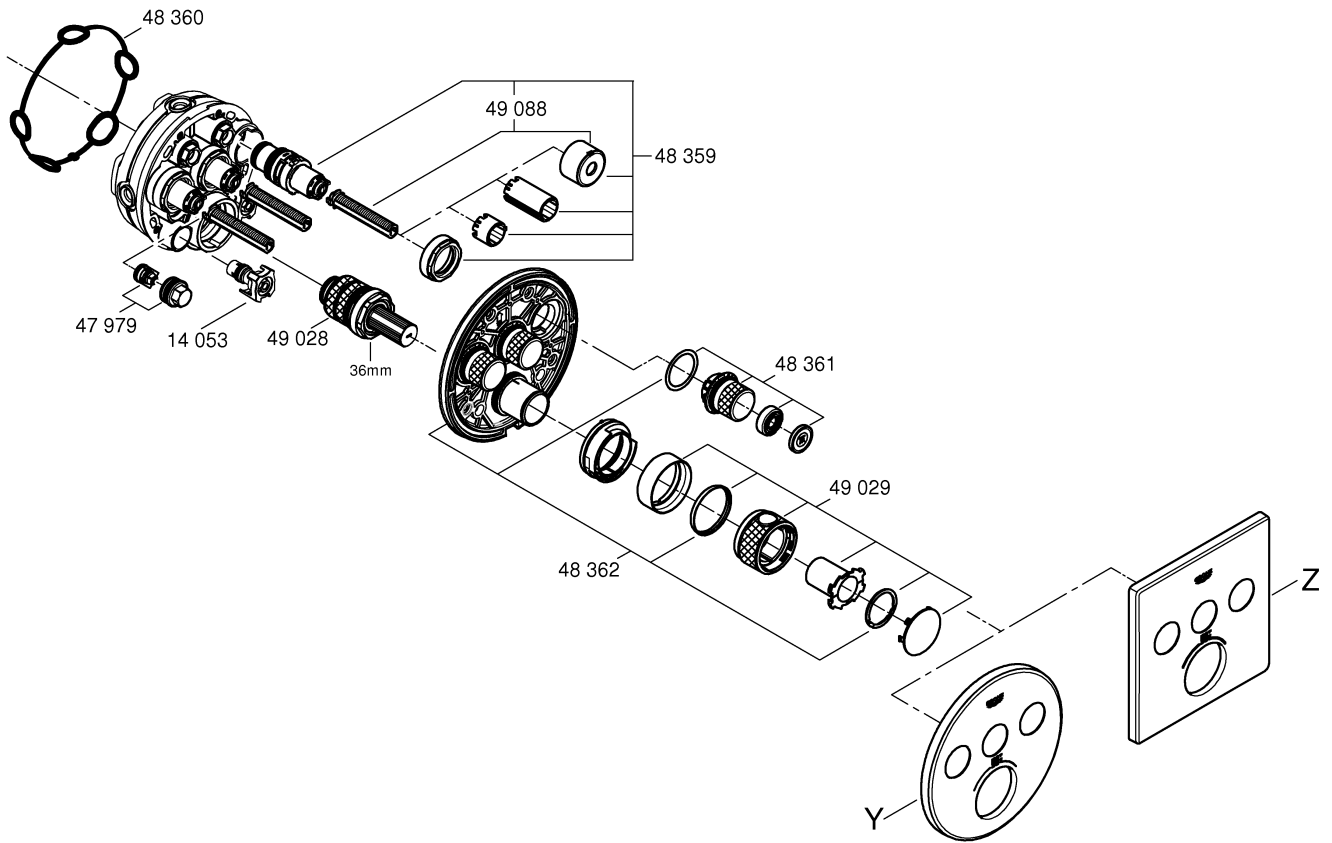

*49 059	36mm
*49 003	
*14 048	

Y		Z	
49 048		49 054	
49 049		49 055	

Pure Freude an Wasser

GROHE

D

+49 571 3989 333
helpline@grohe.de

A

+43 1 68060
info-at@grohe.com

AUS

+(61) 1300 54945
grohe_australia@lixil.com

B

+32 16 230660
info.be@grohe.com

BG

+359 2 9719959
grohe-bulgaria@grohe.com

BR

0800 770 1222
falecom@grohe.com

CAU

+99 412 497 09 74
info-az@grohe.com

CDN

+1 888 6447643
info@grohe.ca

CH

+41 44 877 73 00
info@grohe.ch

CN

+86 4008811698
info.cn@grohe.com

CY

+357 22 465200
info@grome.com

CZ

+358 942 451 390
grohe-cz@grohe.com

DK

+45 44 656800
grohe@grohe.fi

E

+34 93 3368850
grohe@grohe.es

EST

+372 6616354
grohe@grohe.ee

F

+33 1 49972900
sav-fr@grohe.com

FIN

+358 942 451 390
grohe@grohe.fi

GB

+44 871 200 3414
info-uk@grohe.com

GR

+30 210 2712908
nsapountzis@ath.forthnet.gr

H

+36 1 2388045
info-hu@grohe.com

HK

+852 2969 7067
info@grohe.hk

I

+39 2 959401
info-it@grohe.com

IND

+91 1800 102 4475
customercare.in@grohe.com

IS

+354 515 4000
jonst@byko.is

J

+81 3 32989730
info@grohe.co.jp

KZ

+7 727 311 07 39
info-cac@grohe.com

LT

+372 6616354
grohe@grohe.ee

LV

+372 6616354
grohe@grohe.ee

MAL

info-malaysia@grohe.com

MX

01800 8391200
pregunta@grohe.com

N

+47 22 072070
grohe@grohe.no

NL

+31 79 3680133
vragen-nl@grohe.com

NZ

technicalenquiries@paterson
trading.co.nz

P

+351 234 529620
commercial-pt@grohe.com

PL

+48 22 5432640
biuro@grohe.com.pl

RI

0-800-1-046743
customercare-
indonesia@asia.lixil.com

RO

+40 21 2125050
info-ro@grohe.com

ROK

+82 2 1588 5903
info-singapore@grohe.com

RP

+63 2 8938681

RUS

+7 495 9819510
info@grohe.ru

S

+46 771 141314
grohe@grohe.se

SGP

+65 6311 3611
info-singapore@grohe.com

SK

+420 277 004 190
grohe-cz@grohe.com

T

+66 21681368
(Haco Group)
info@haco.co.th

TR

+90 216 441 23 70
GroheTurkey@grome.com

UA

+38 44 5375273
info-ua@grohe.com

USA

+1 800 4447643
us-customerservice@grohe.com

VN

+84 90 9694768
+84 90 9375068
info-vietnam@grohe.com

AL **BiH** **HR** **KS**

ME **MK** **SLO** **SRB**

+385 1 2911470
adria-hr@grohe.com

Eastern Mediterranean,

Middle East - Africa

Area Sales Office:

+357 22 465200
info@grome.com

IR **OM** **UAE** **YEM**

+971 4 3318070
grohedubai@grome.com

Far East Area Sales Office:

+65 6311 3600
info@grohe.com.sg

Latin America:

+52 818 3050626
pregunta@grohe.com

www.grohe.com

2016/09/28

35 601

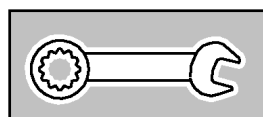
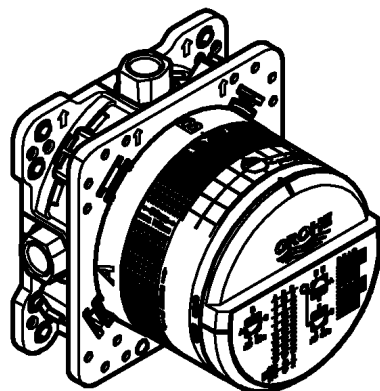

1-9

Grohtherm SmartControl

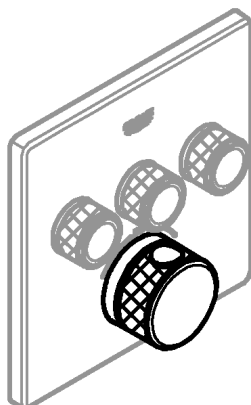

10-24

Grohtherm 2-Handle Thermostat

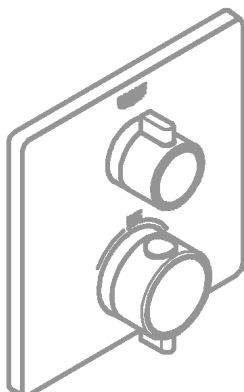

25-30

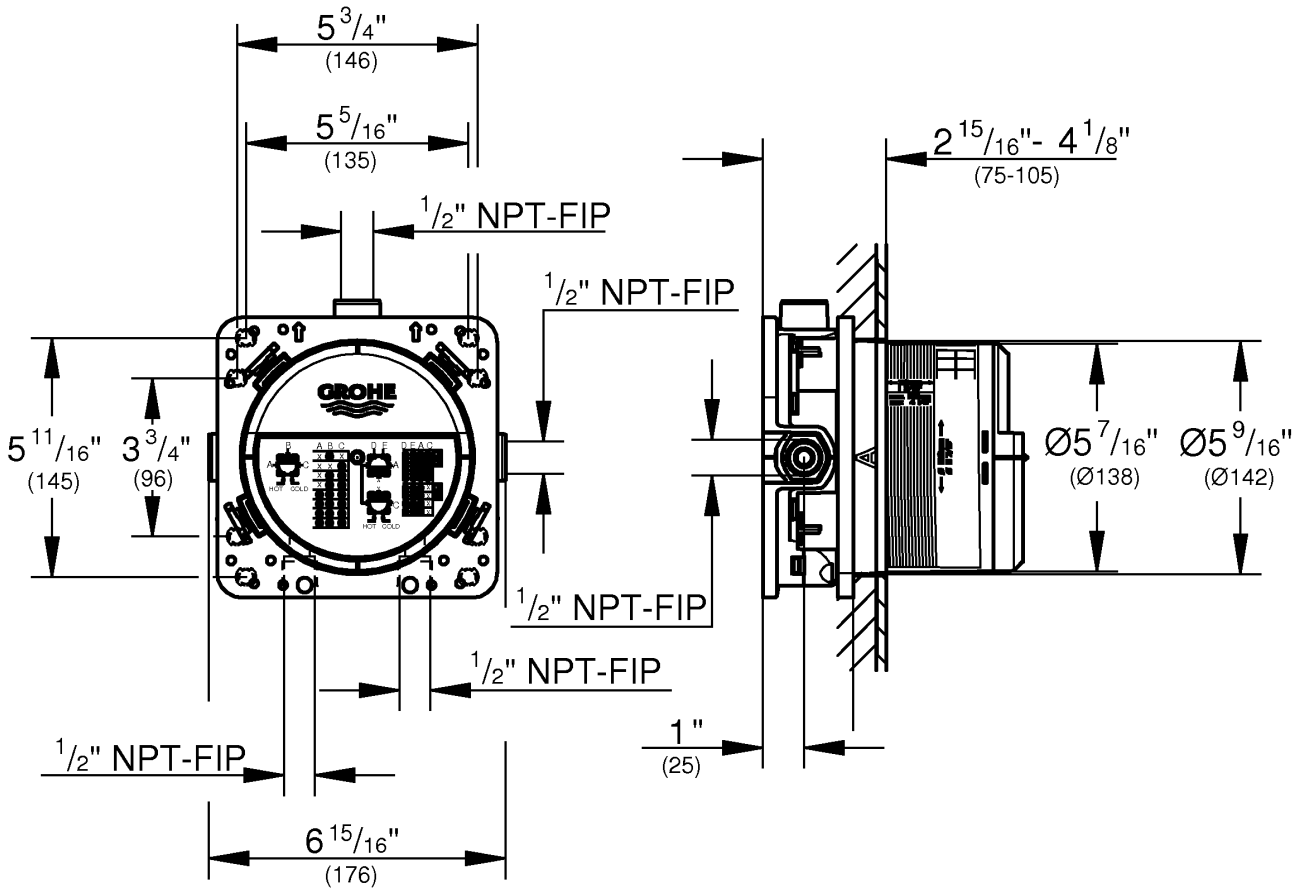
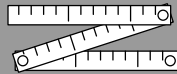
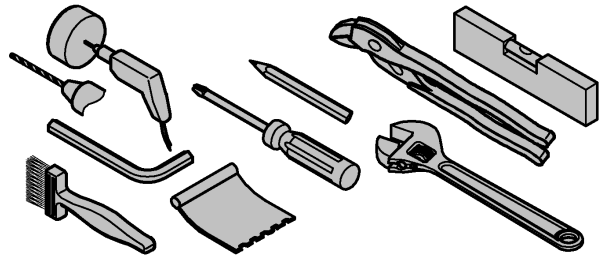
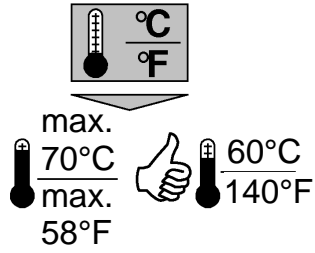
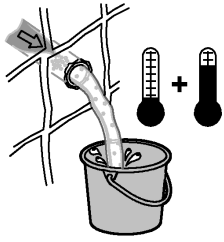

Applications

Operation is possible with:

- Pressurised storage heaters
- Thermally/hydraulically controlled instantaneous water heaters

Operation with unpressurised storage heaters (displacement water heaters) is **not** possible!

Technical data

- Operating pressure: max.145 psi
- Test pressure 232 psi

Note:

To comply with noise levels if static pressure exceeds 72.5 psi, a pressure reducing valve must be fitted.

Installation options, see pages 4-9.

- Installation in studding
- Installation with spacers
- Installation directly on the wall
- Installation in the wall
- Installation on prefabricated house assembly plates or prefabricated shells

Installation of the box

- Make drill holes for the box and slots for the pipes.
- Installation depth 2 15/16" - 4 1/8".
- If the box is installed too deeply an extension can be applied.

Connecting the pipes

The outflows intended for this purpose are to be used.

- Recommended configuration options:
 - Grohtherm SmartControl see from page 10-24.
 - Grohtherm 2-Handle Thermostat see from page 25-30.
- Non-binding outflows must be sealed with the accompanying plug (X).
- Check connections for water-tightness.
- **Plugs (Y) must be assembled**, see page 8, Fig. [6].

Apply carrier material as sealant, see page 9, Fig. [9] to [11].

Plaster and tile the wall.

Do **not** cut the fitting template prior to final installation.

Domaine d'application

Utilisation possible avec :

- Réservoirs sous pression
- Chauffe-eau instantanés hydrauliques/thermiques

Le fonctionnement avec des accumulateurs sans pression (chauffe-eau à écoulement libre) **n'est pas possible !**

Caractéristiques techniques

- Pression de service max.10 bars
- Pression d'épreuve 16 bars

Remarque :

Il est recommandé d'installer un réducteur de pression en cas de pressions statiques supérieures à 5 bars.

Possibilités de montage, voir pages 4-9.

- Montage dans un support charpenté
- Montage avec entretoises
- Montage directement sur le mur
- Montage dans le mur
- Montage sur plaques de montage pour préfabriqué ou plaques pré-fabriquées

Installation du boîtier

- Préparer des trous pour le boîtier et des fentes pour les canalisations.
- Profondeur de montage : 75-105mm.
- Si le boîtier est installé trop en profondeur, il est possible d'utiliser une rallonge.

Brancher les canalisations

Il convient d'utiliser les sorties prévues à cet effet.

- Possibilités de configuration recommandées :
 - Grohtherm SmartControl voir à partir de la page 10-24.
 - Grohtherm 2-Handle Thermostat voir à partir de la page 25-30.
- Les sorties non obstruées doivent être étanchéifiées à l'aide des bouchons (X) fournis.
- Vérifier l'étanchéité des raccordements.
- **Les bouchons (Y) doit être monté**, voir page 8, fig. [6].

Monter le support pour le produit d'étanchéité, voir page 9, fig. [9] à [11].

Enduire complètement le mur et le carreler.

Ne pas raccourcir le gabarit de montage avant le montage final.

E

Campo de aplicación

Es posible el funcionamiento con:

- Acumuladores de presión
- Calentadores instantáneos con control hidráulico/ térmico

No es posible el funcionamiento con acumuladores sin presión (calentadores de agua sin presión).

Datos técnicos

- Presión de utilización máx. 145 psi
- Presión de verificación 232 psi

Nota:

Si la presión en reposo es superior a 72.5 psi, se recomienda instalar un reductor de presión para alcanzar los valores de emisión de ruidos.

Posibilidades de montaje, véanse las páginas 4-9.

- Montaje en una pared de tablonos
- Montaje con separador
- Montaje directo en la pared
- Montaje en la pared
- Montaje en placas de montaje de viviendas prefabricadas o células acabadas

Instalación de la caja

- Hacer orificios en la caja así como ranuras en las tuberías.
- Profundidad de montaje 2 15/16"- 4 1/8".
- Si la caja se ha montado en un sitio demasiado profundo, se puede introducir una prolongación.

Conectar las tuberías

Se deben utilizar las salidas previstas para ello.

- Posibilidades de configuración recomendadas:
 - Véase Grohtherm SmartControl a partir de la página 10-24.
 - Véase Grohtherm SmartControl a partir de la página 25-30.
- Las salidas libres se deben sellar con el tapón suministrado (X).
- Comprobar la estanqueidad de las conexiones.
- **Los tapones (Y) se debe montar**, véase la página 8, fig. [6].

Conseguir material de base para el impermeabilizante, véase la página 9, fig. [9] hasta la [11].

Concluir el enlucido y alicatado de la pared.

No acortar la plantilla de montaje antes de proceder con la instalación de acabado.

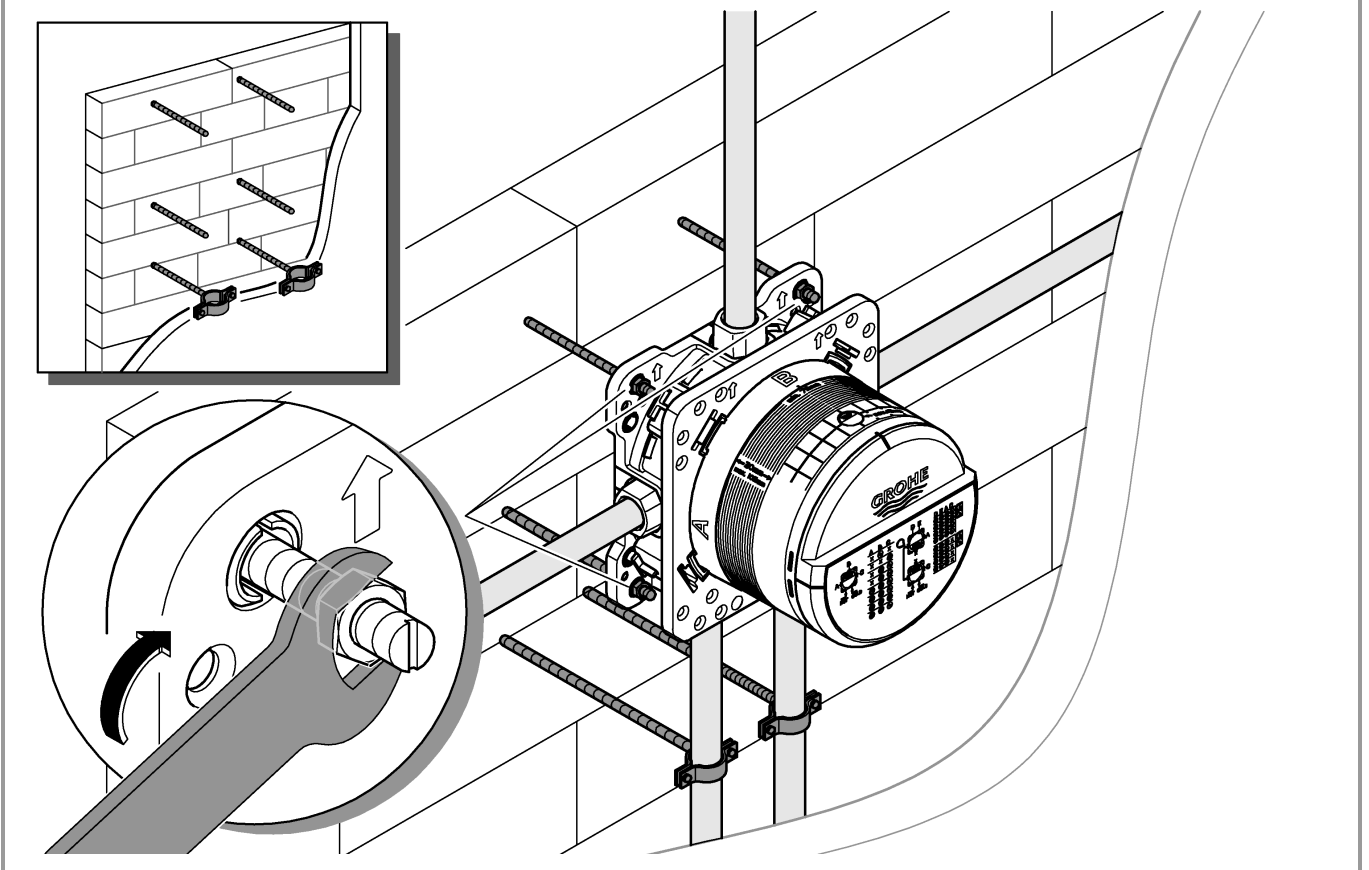
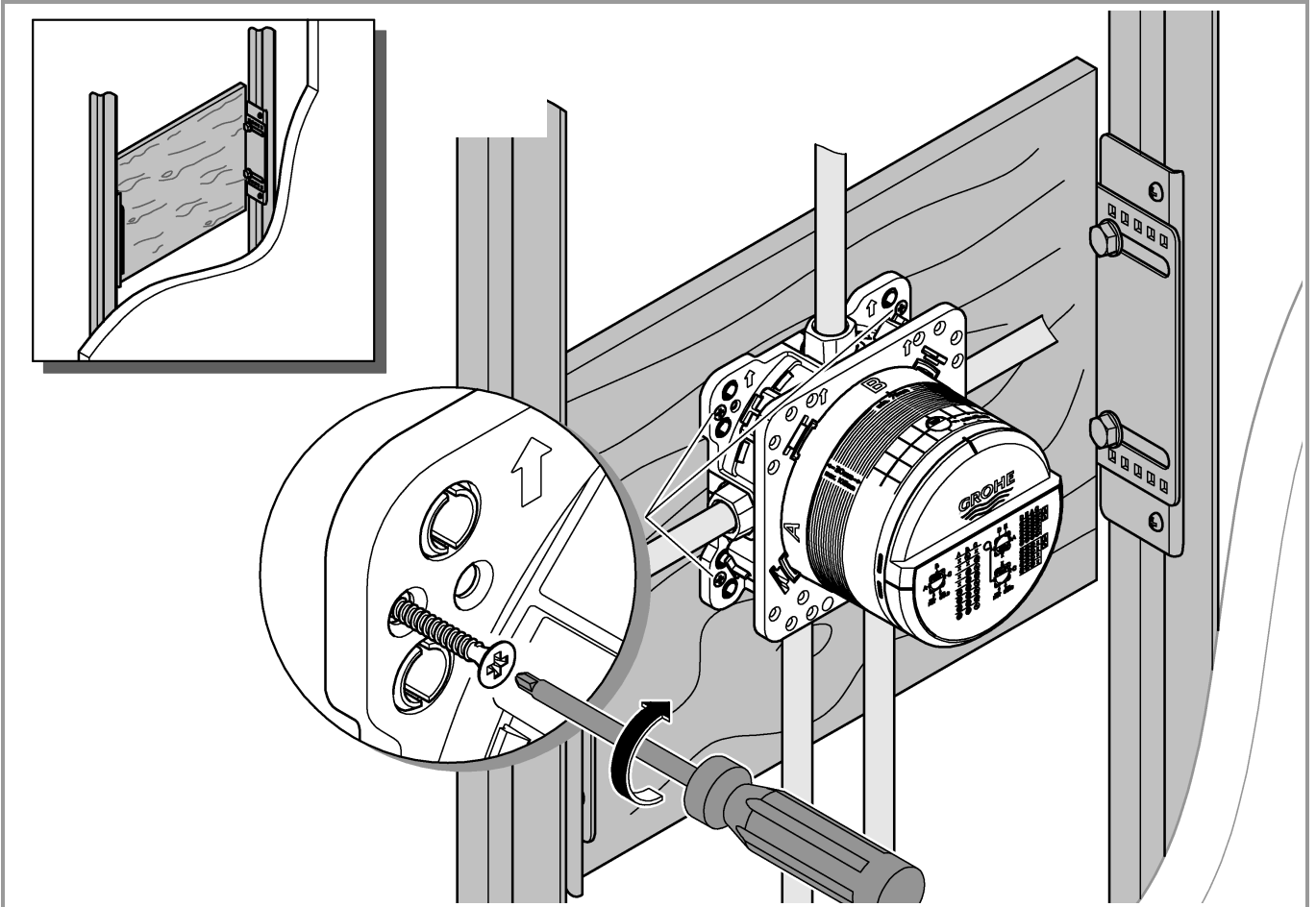

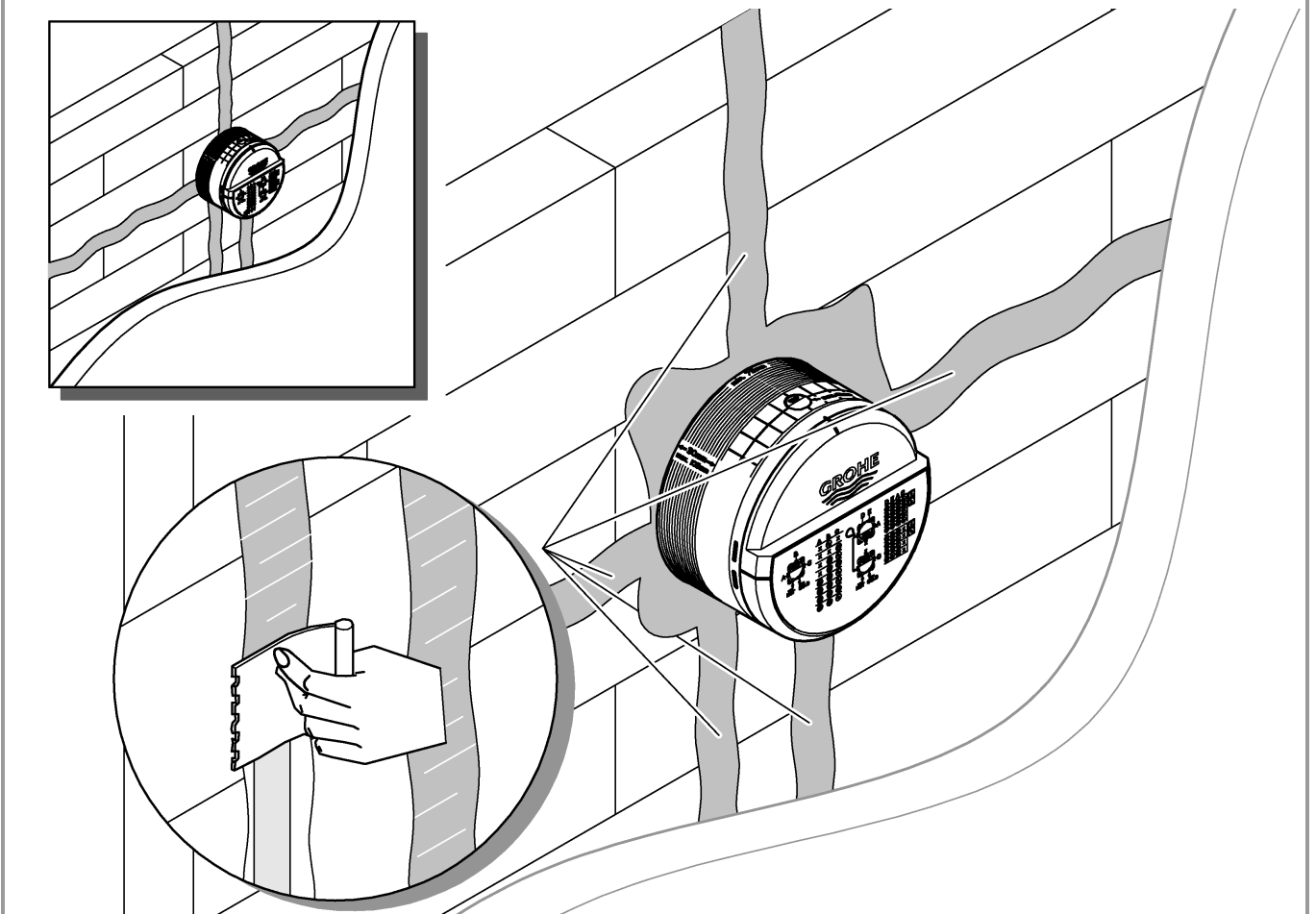
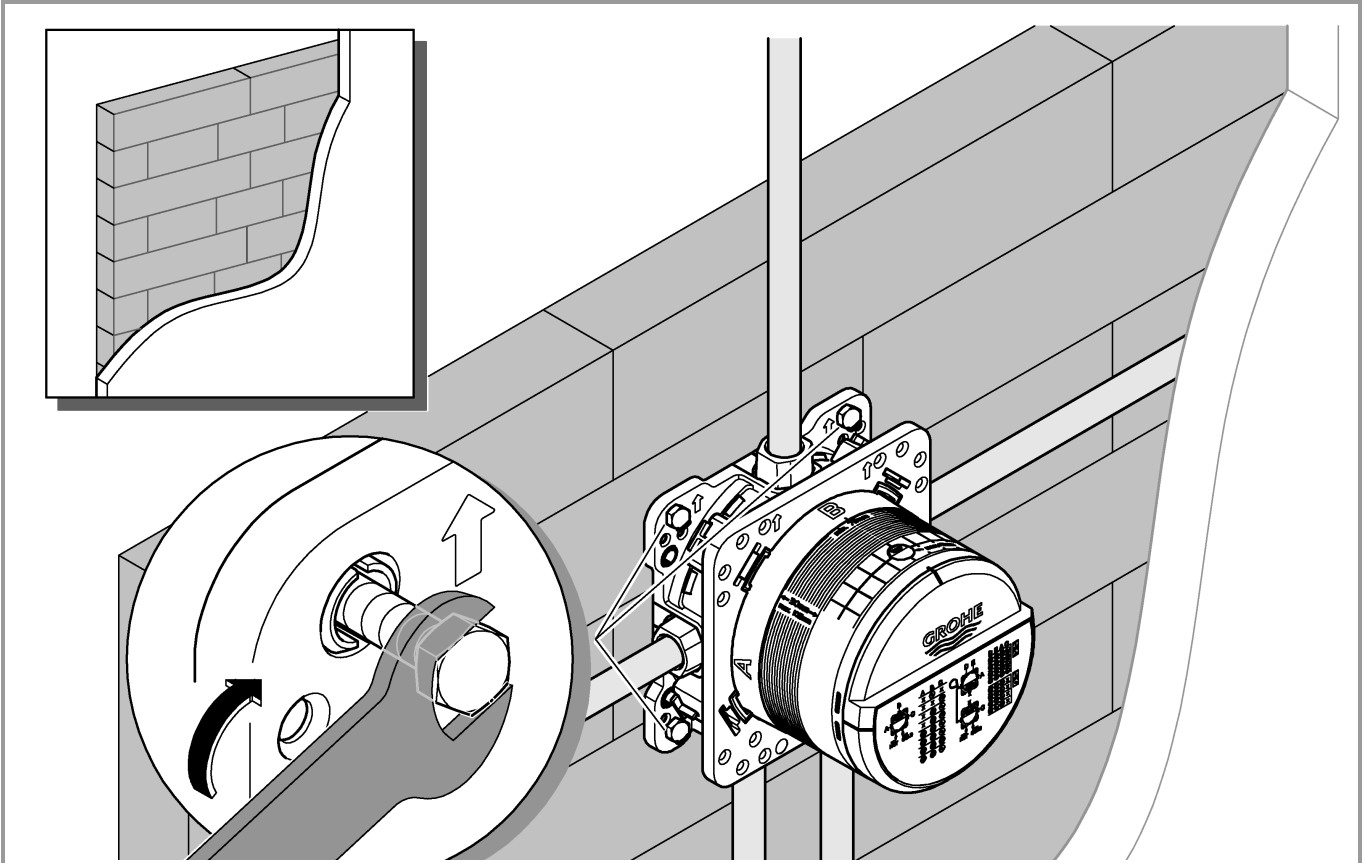

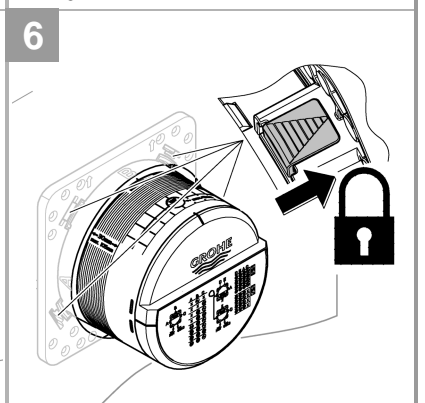
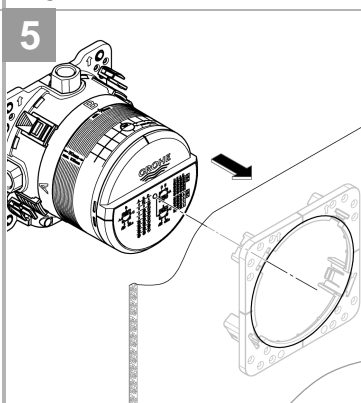
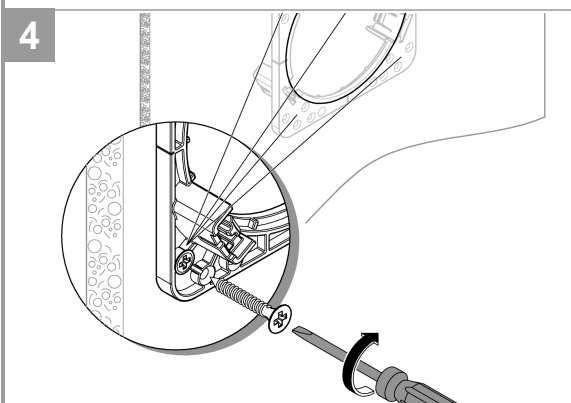
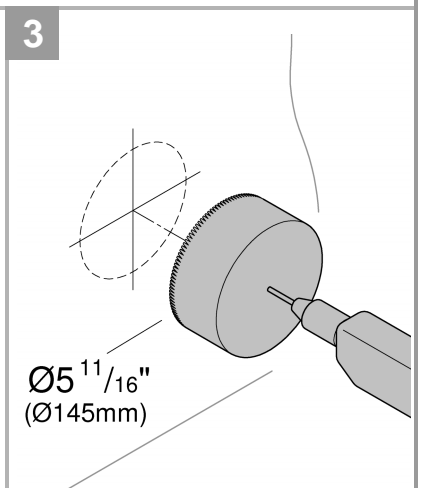
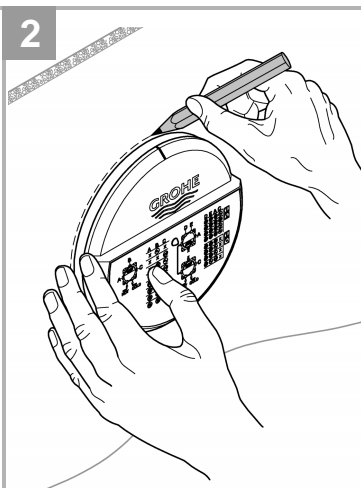
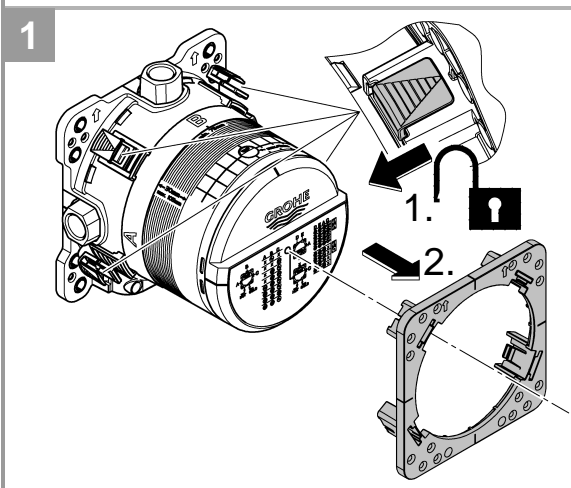
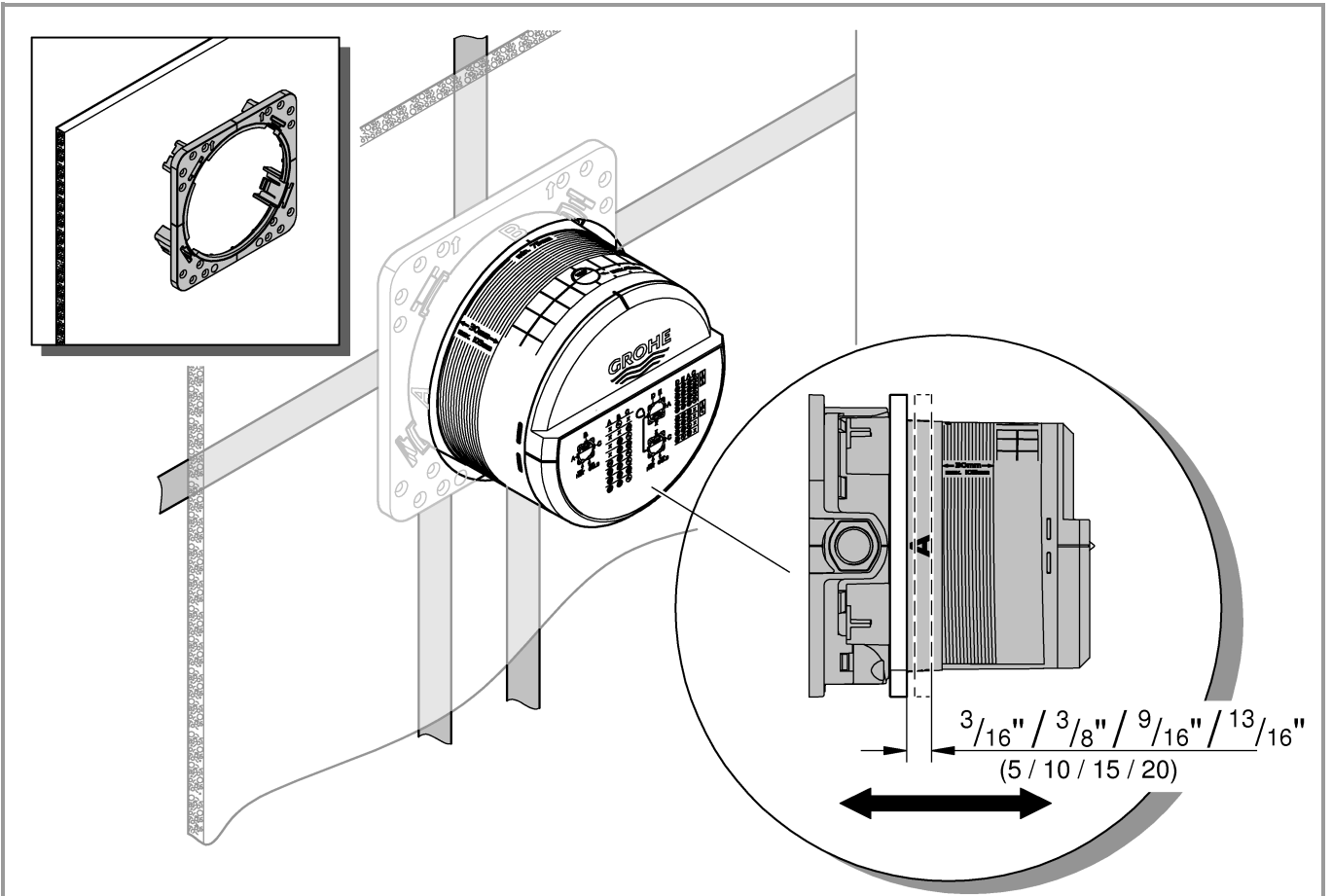



1

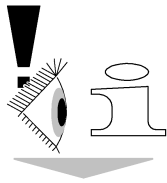

Grotherm Smart Control



10-24

Grotherm 2-Handle Thermostat



25-30

1/2" NPT-FIP

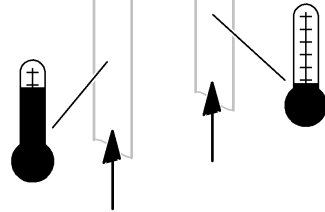
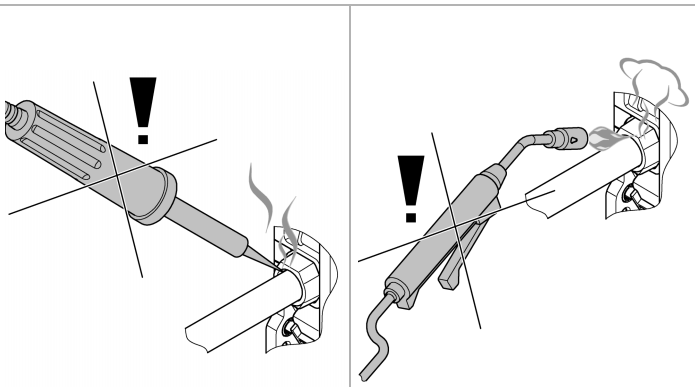
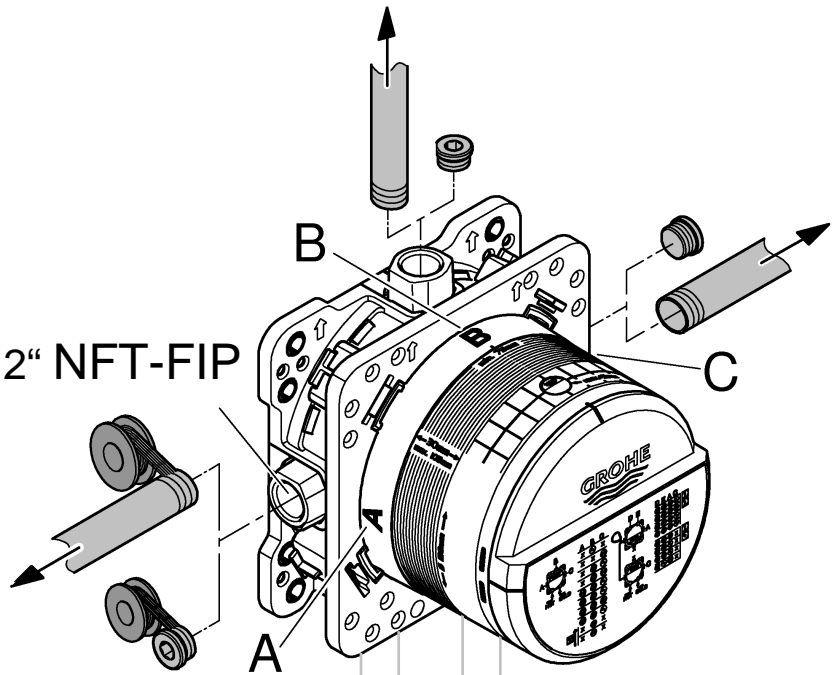

2

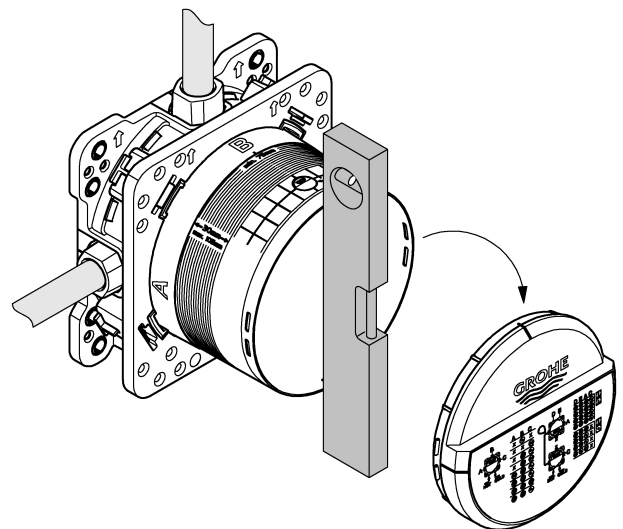
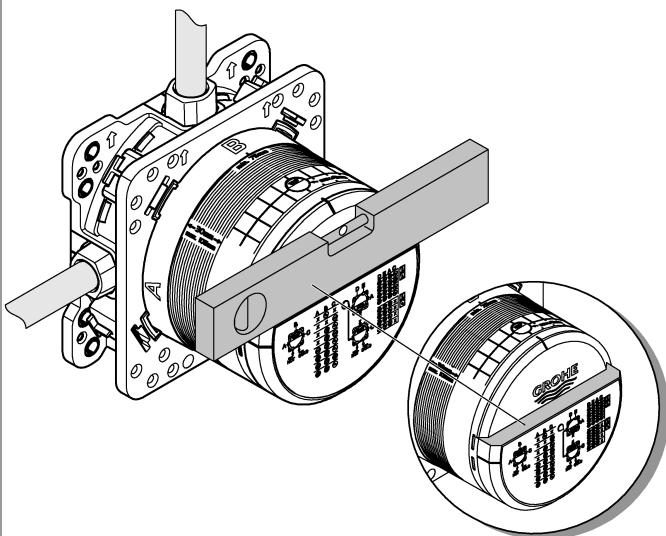



3

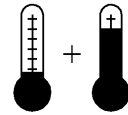
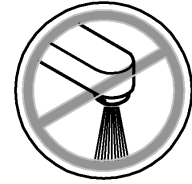
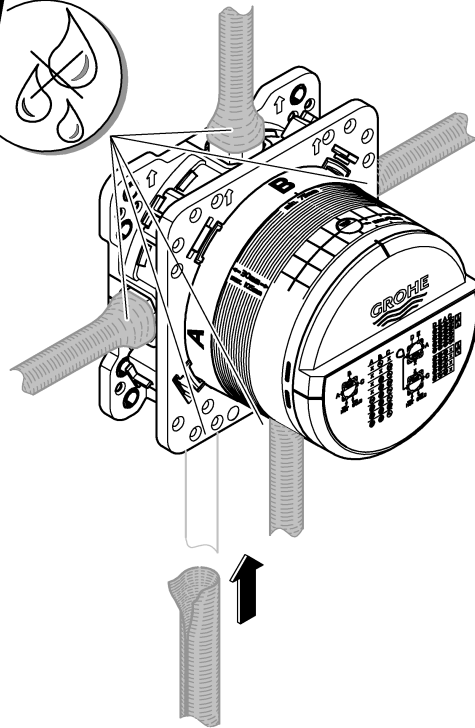
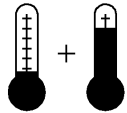
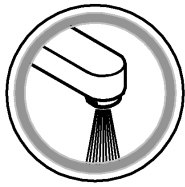

4

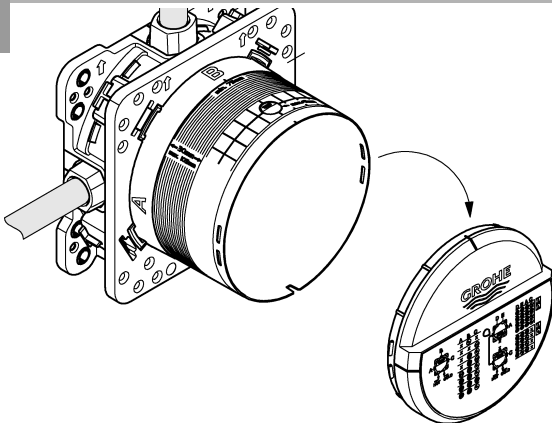

5

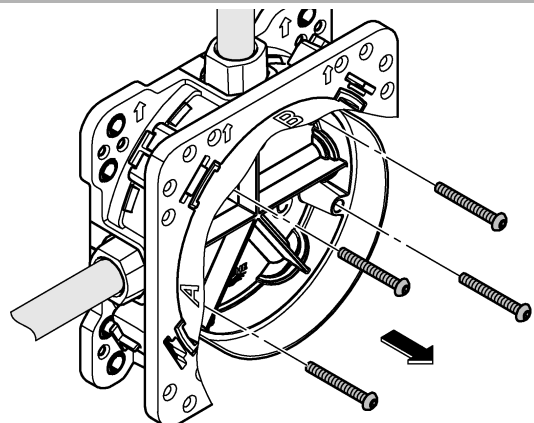

6

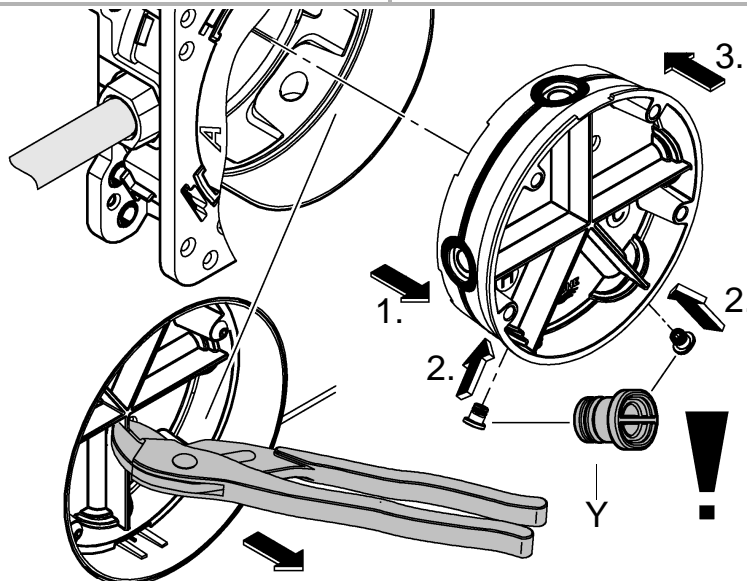



7

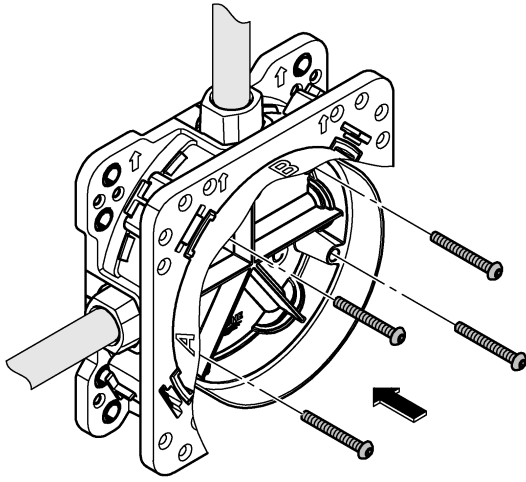

8

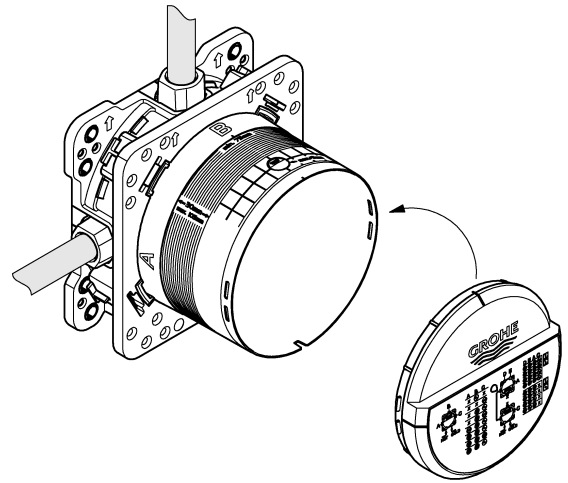

i

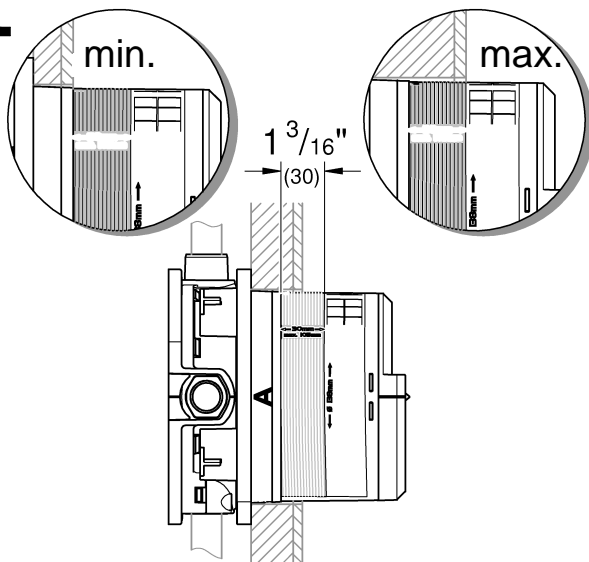

9

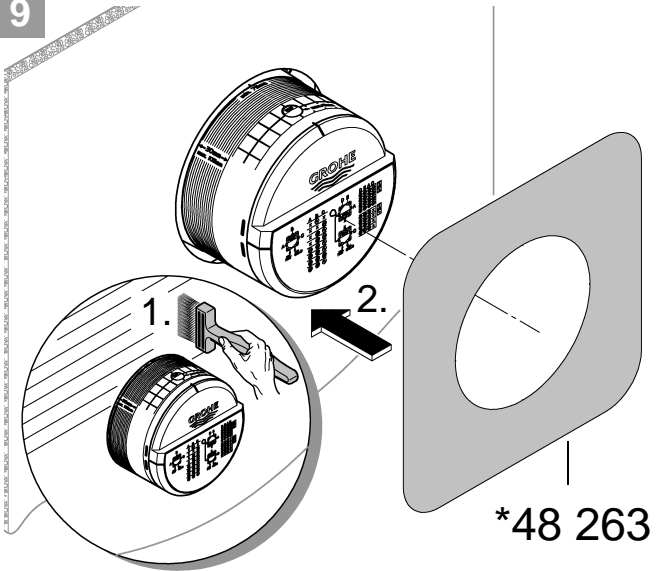

10

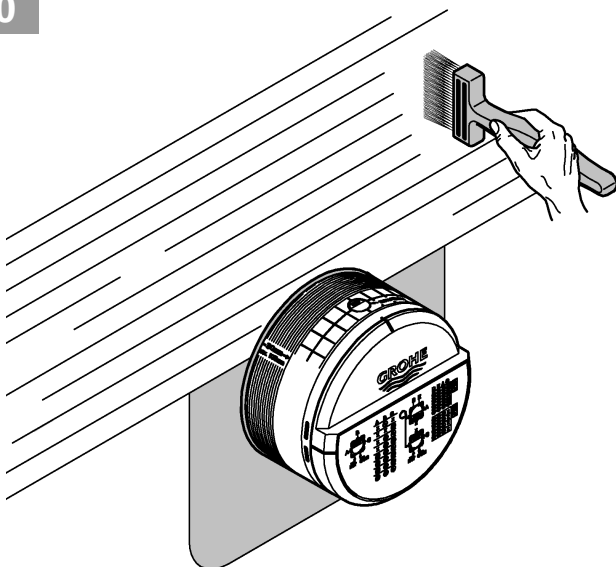

11

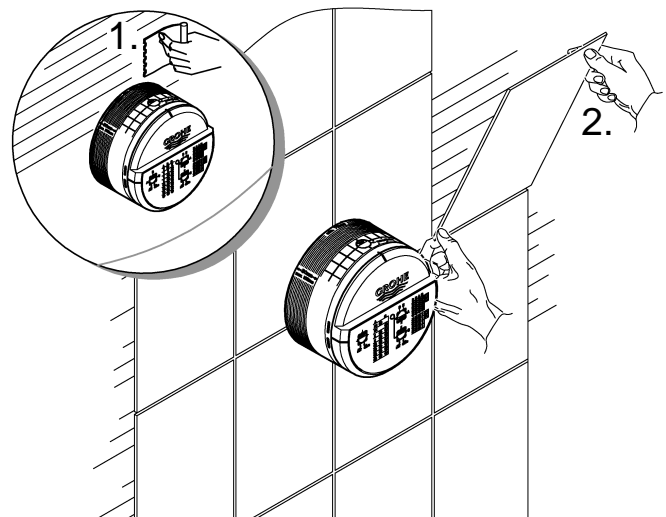

USA

Technical specifications Grotherm SmartControl

Thermostat

- Flow pressure
 - Minimum flow pressure without downstream resistances 7.25 psi
 - Minimum flow pressure with downstream resistances 14.5 psi
 - Recommended 21.75 – 72.5 psi
- Temperature
 - Hot water inlet max. 158 °F
 - Recommended for energy saving 140 °F
 - Thermal disinfection possible
- Hot water temperature at supply connection min. 3.6 °F higher than mixed water temperature

Flow rates without downstream resistances, see page 12-24. **These are to be observed when dimensioning the outlet!**

- Recommended configuration options, see from page 11-24.

The following special accessories are available:

- Extension 1" (prod. no.: 14 048)
- Service stops (prod. no.: 14 053)
- Reversed connection, hot on right – cold on left replace thermostat cartridges (prod. no.: 49 003)

F

Caractéristiques techniques Grotherm SmartControl

Thermostat

- Pression dynamique
 - Pression dynamique minimale sans résistances en aval 0,5 bar
 - Pression dynamique minimale avec résistances en aval 1 bar
 - Recommandée 1,5 à 5 bars
- Température
 - Arrivée d'eau chaude max. 70 °C
 - Recommandée pour une économie d'énergie 60 °C
 - Désinfection thermique possible
- Température de l'eau chaude au raccord d'alimentation au moins 2 °C de plus que la température de l'eau mitigée

Débits sans résistances en aval, voir pages 12-24.

Veillez en tenir compte lors du

dimensionnement de l'évacuation!

- Possibilités de configuration recommandées, voir à partir de la page 11-24.

Les accessoires spéciaux suivants sont disponibles :

- Rallonge de 25mm (réf. : 14 048)
- Robinets d'arrêt (réf. : 14 053)
- Raccordement inversé, chaud à droite - froid à gauche, remplacer la cartouche du thermostat (réf. : 49 003)

E

Datos técnicos de Grotherm SmartControl

Thermostat

- Presión de trabajo
 - Presión mínima de trabajo sin resistencias posacopladas 7.25 psi
 - Presión mínima de trabajo con resistencias posacopladas 14.5 psi
 - Presión recomendada 21.75 – 72.5 psi
- Temperatura
 - Entrada de agua caliente máx. 158 °F
 - Recomendada para ahorrar energía 140 °F
 - Desinfección térmica posible
- La temperatura del agua caliente en la acometida min. 3.6 °F superior a la temperatura del agua mezclada

Caudales sin resistencias posacopladas, véanse las páginas 12-24. **Tenga en cuenta las dimensiones del desagüe.**

- Posibilidades de configuración recomendadas, véase a partir de la página 11-24.

Los siguientes accesorios opcionales están disponibles:

- Prolongación de 1" (n.º de pedido: 14 048)
- Bloqueos de seguridad (n.º de pedido: 14 053)
- Conexión invertida, derecha caliente - izquierda frío sustituir los cartuchos del termostato (n.º de pedido: 49 003)

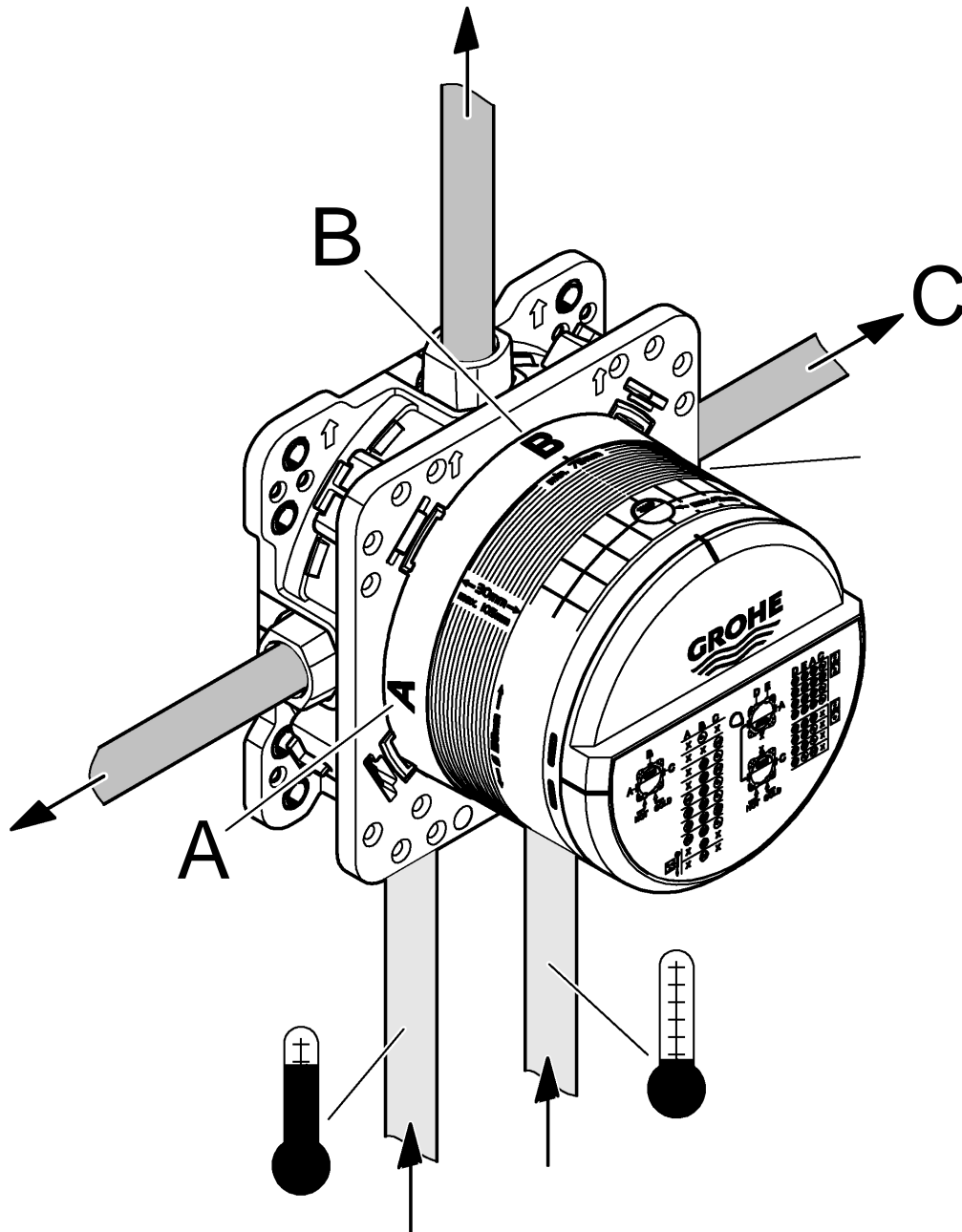



Grohtherm SmartControl

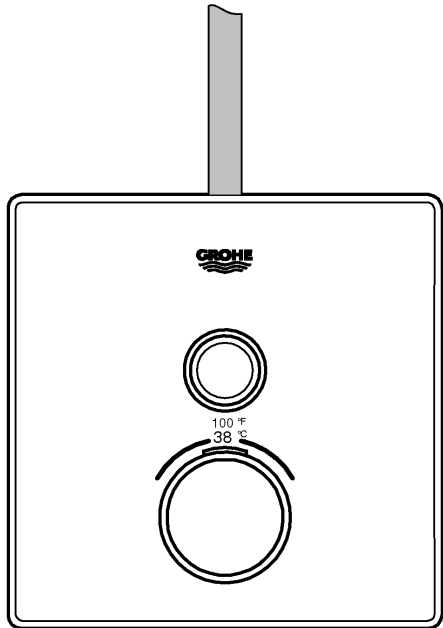

A	psi						B
	14,5	29	43,5	58	72,5	87	
B	4,4	6,3	7,7	8,8	9,9	10,8	gpm

A	bar						B
	1	2	3	4	5	6	
B	16,7	23,7	29	33,5	37,4	41	l/min

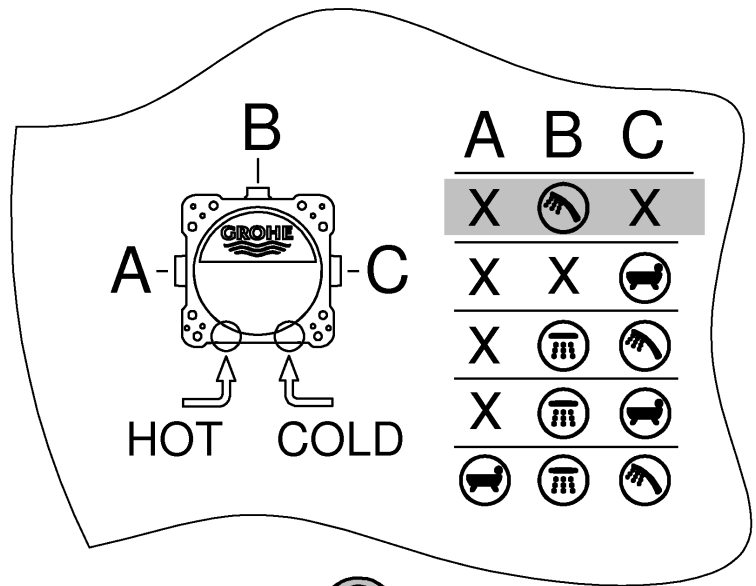

(A+C) X=



Grohtherm SmartControl

	psi						gpm
	14,5	29	43,5	58	72,5	87	
C	4,4	6,3	7,7	8,8	9,9	10,8	

	bar						l/min
	1	2	3	4	5	6	
C	16,7	23,7	29	33,5	37,4	41	

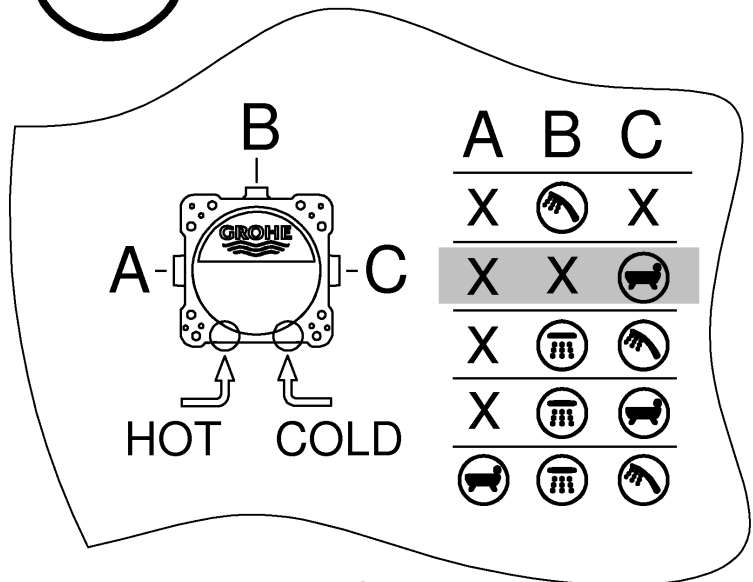
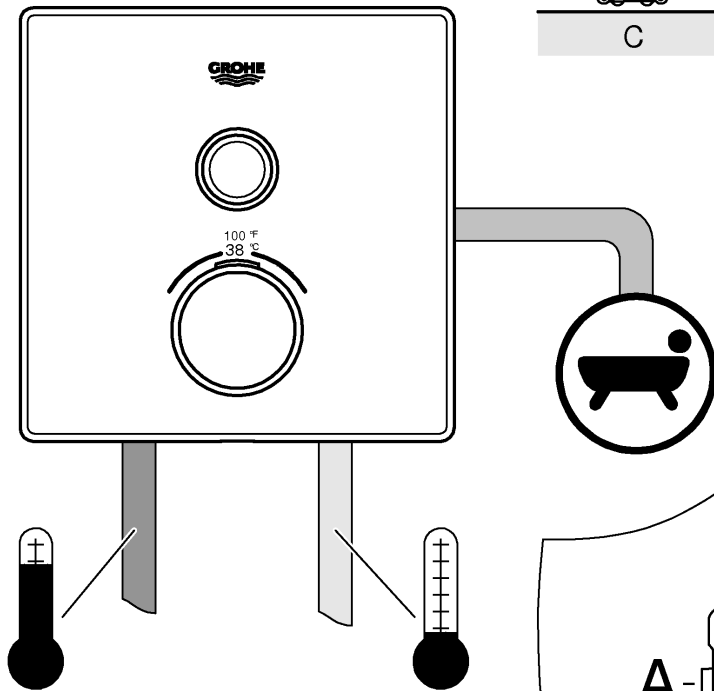

(A+B) X=



Grotherm SmartControl

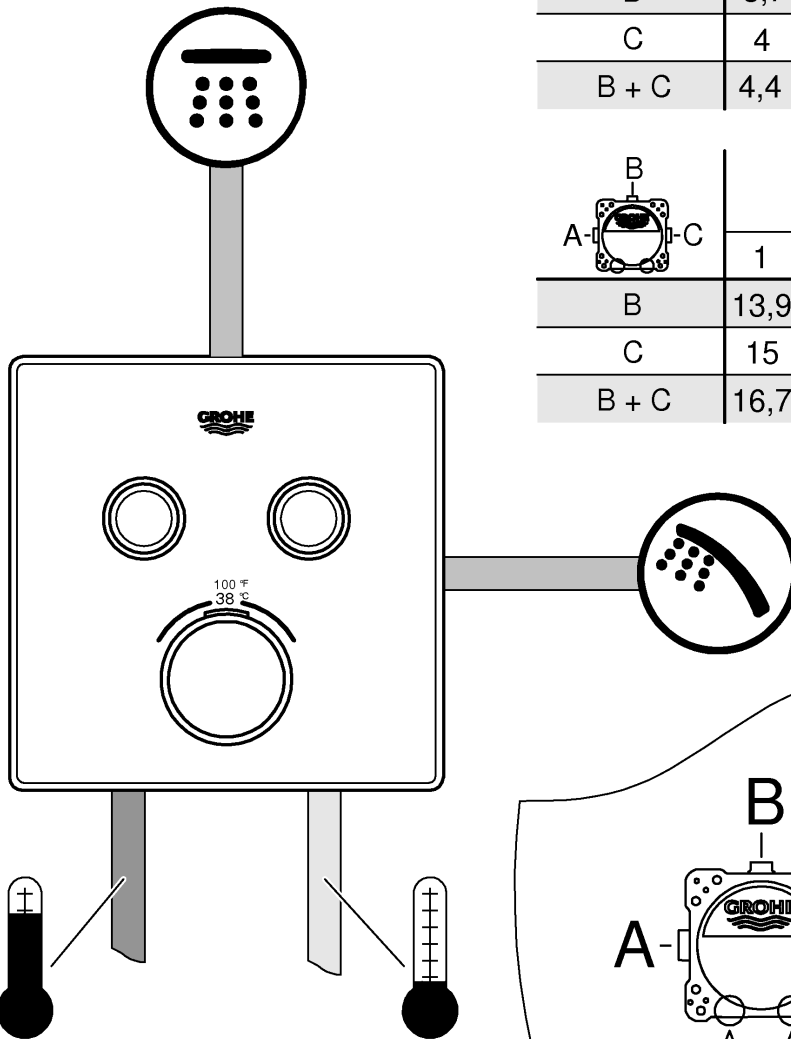

A- -C	psi						gpm
	14,5	29	43,5	58	72,5	87	
B	3,7	5,2	6,3	7,3	8,2	9	
C	4	5,6	6,9	7,9	8,9	9,7	
B + C	4,4	6,3	7,7	8,8	9,9	10,8	

A- -C	bar						l/min
	1	2	3	4	5	6	
B	13,9	19,6	24	27,7	31	33,9	
C	15	21,2	26	30	33,6	36,8	
B + C	16,7	23,7	29	33,5	37,4	41	

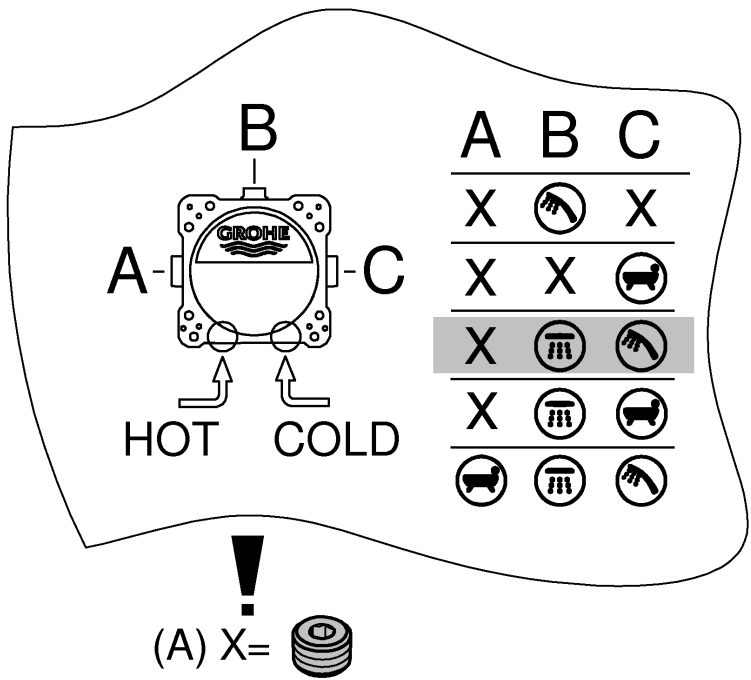





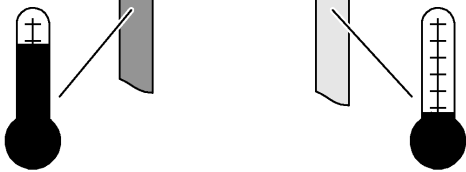
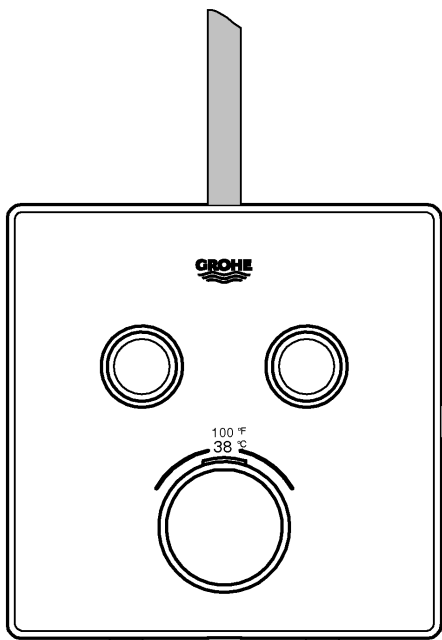
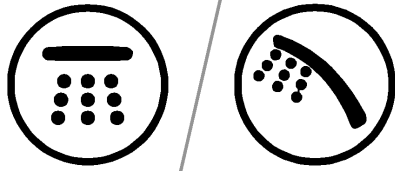

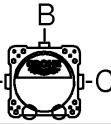

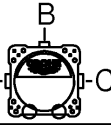

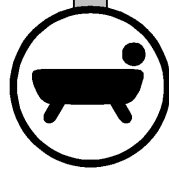

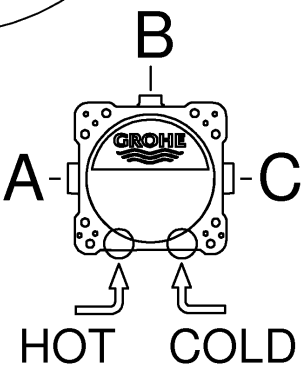



Grohtherm SmartControl

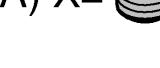

	psi						gpm
	14,5	29	43,5	58	72,5	87	
B	3,7	5,2	6,3	7,3	8,2	9	
C	4	5,6	6,9	7,9	8,9	9,7	
B + C	4,4	6,3	7,7	8,8	9,9	10,8	

	bar						l/min
	1	2	3	4	5	6	
B	13,9	19,6	24	27,7	31	33,9	
C	15	21,2	26	30	33,6	36,8	
B + C	16,7	23,7	29	33,5	37,4	41	



	A	B	C
	X		X
	X	X	
	X		
	X		
			

(A) X = 

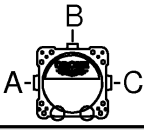

Grotherm SmartControl

	psi						gpm
	14,5	29	43,5	58	72,5	87	
A	3,5	5	6,1	7	7,8	8,6	
B	4,1	5,8	7,1	8,2	9,2	10,1	
C	3,5	5	6,1	7	7,8	8,6	
A+B	5	7,1	8,7	10,1	11,3	12,3	
A+B+C	5,5	7,8	9,5	11	12,3	13,4	

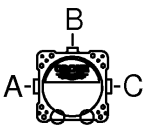
	bar						l/min
	1	2	3	4	5	6	
A	13,3	18,8	23	26,6	29,7	32,5	
B	15,6	22	27	31,2	34,9	38,2	
C	13,3	18,8	23	26,6	29,7	32,5	
A+B	19,1	26,9	33	38,1	42,6	46,7	
A+B+C	20,8	29,4	36	41,6	46,5	50,9	

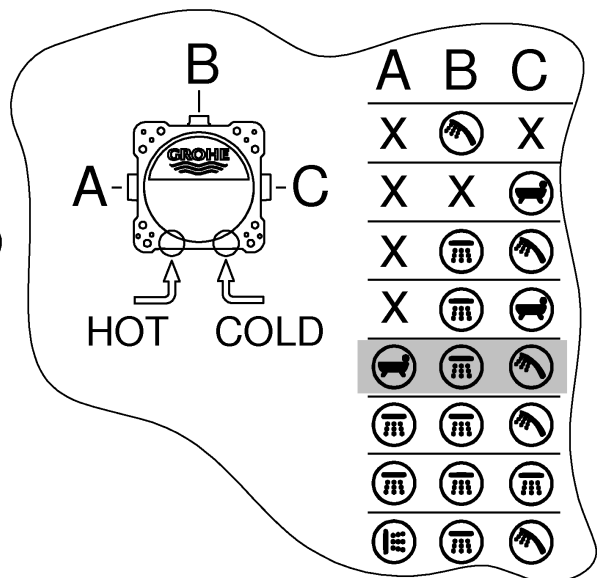
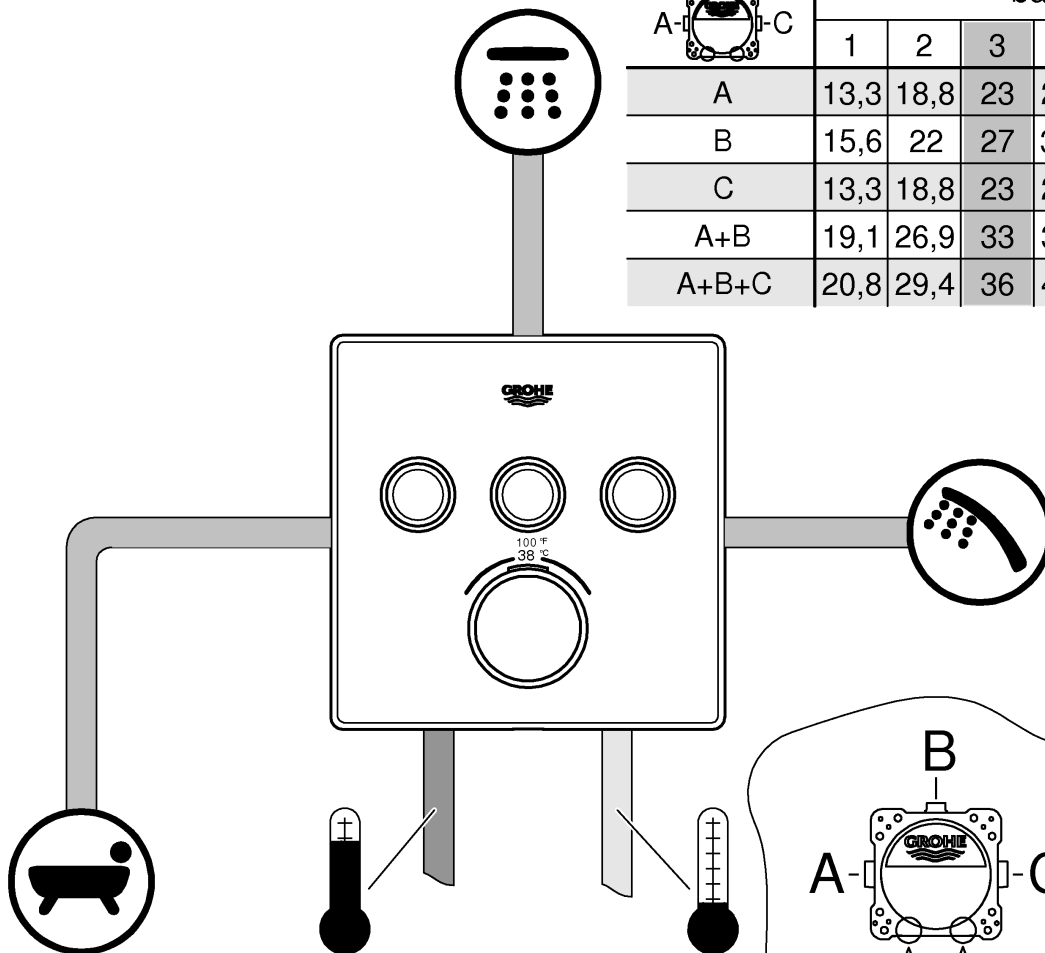

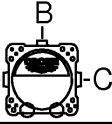

Grotherm SmartControl

	psi					
	14,5	29	43,5	58	72,5	87
A	3,5	5	6,1	7	7,8	8,6
B	4,1	5,8	7,1	8,2	9,2	10,1
C	3,5	5	6,1	7	7,8	8,6
A+B	5	7,1	8,7	10,1	11,3	12,3
A+B+C	5,5	7,8	9,5	11	12,3	13,4

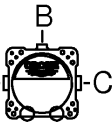
	bar					
	1	2	3	4	5	6
A	13,3	18,8	23	26,6	29,7	32,5
B	15,6	22	27	31,2	34,9	38,2
C	13,3	18,8	23	26,6	29,7	32,5
A+B	19,1	26,9	33	38,1	42,6	46,7
A+B+C	20,8	29,4	36	41,6	46,5	50,9

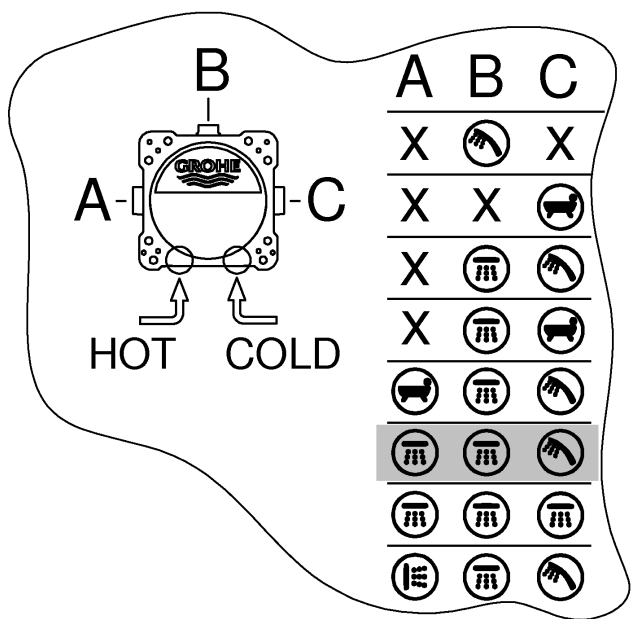
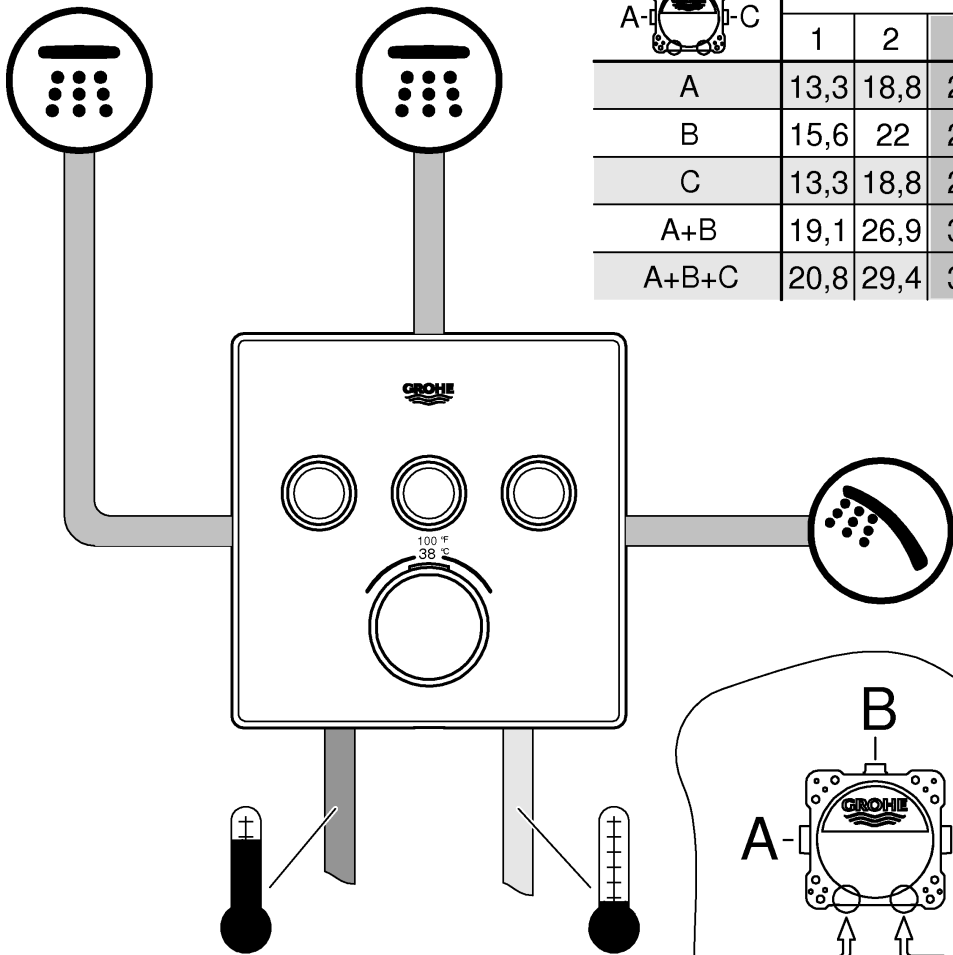

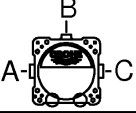

Grotherm SmartControl

	bar					
	1	2	3	4	5	6
A	13,3	18,8	23	26,6	29,7	32,5
B	15,6	22	27	31,2	34,9	38,2
C	13,3	18,8	23	26,6	29,7	32,5
A+B	19,1	26,9	33	38,1	42,6	46,7
A+B+C	20,8	29,4	36	41,6	46,5	50,9

l/min

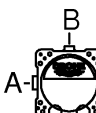
	psi					
	14,5	29	43,5	58	72,5	87
A	3,5	5	6,1	7	7,8	8,6
B	4,1	5,8	7,1	8,2	9,2	10,1
C	3,5	5	6,1	7	7,8	8,6
A+B	5	7,1	8,7	10,1	11,3	12,3
A+B+C	5,5	7,8	9,5	11	12,3	13,4

gpm

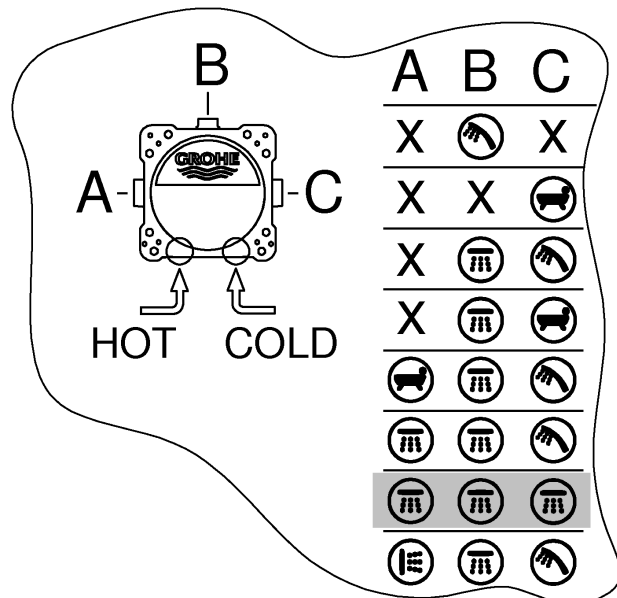
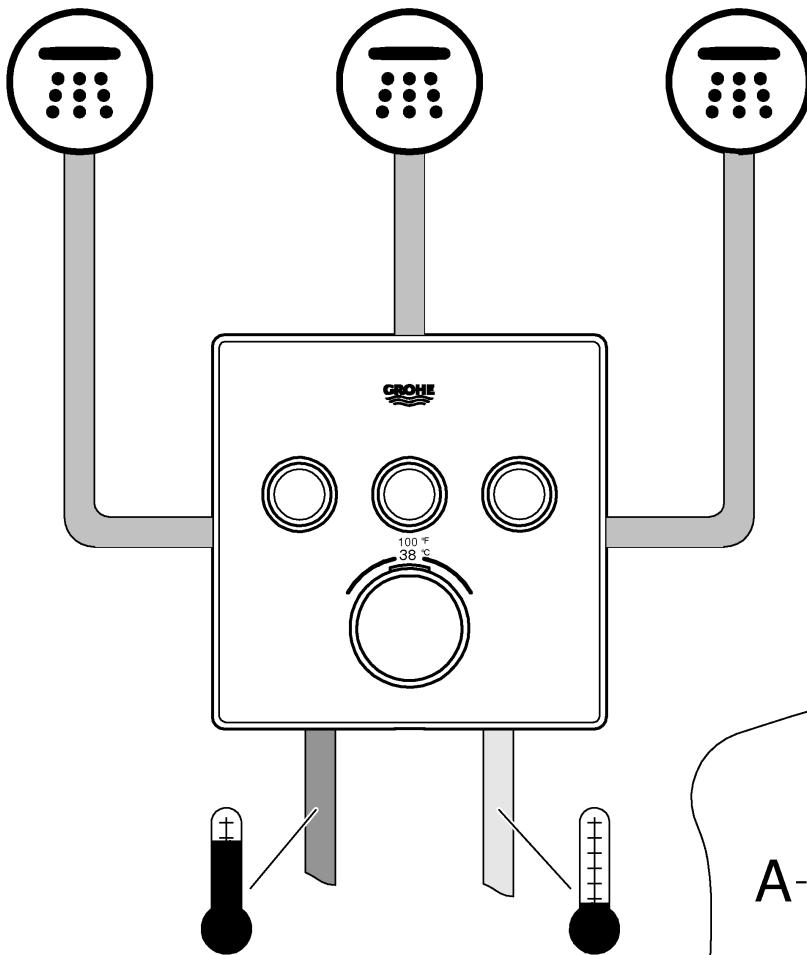

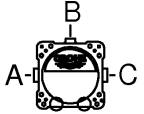

Grotherm SmartControl

	bar						l/min
	1	2	3	4	5	6	
A	13,3	18,8	23	26,6	29,7	32,5	
B	15,6	22	27	31,2	34,9	38,2	
C	13,3	18,8	23	26,6	29,7	32,5	
A+B	19,1	26,9	33	38,1	42,6	46,7	
A+B+C	20,8	29,4	36	41,6	46,5	50,9	

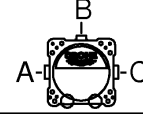
	psi						gpm
	14,5	29	43,5	58	72,5	87	
A	3,5	5	6,1	7	7,8	8,6	
B	4,1	5,8	7,1	8,2	9,2	10,1	
C	3,5	5	6,1	7	7,8	8,6	
A+B	5	7,1	8,7	10,1	11,3	12,3	
A+B+C	5,5	7,8	9,5	11	12,3	13,4	

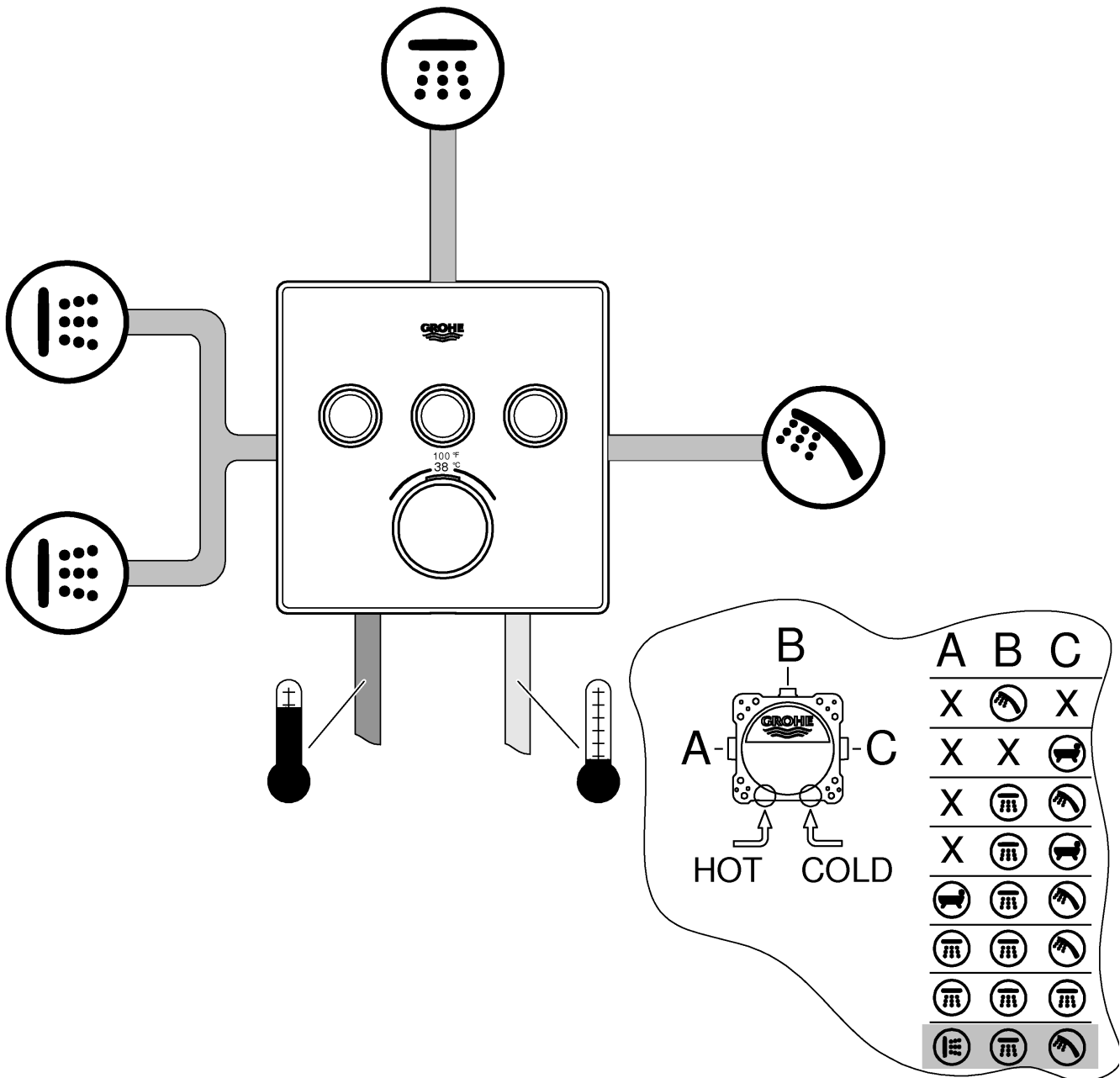

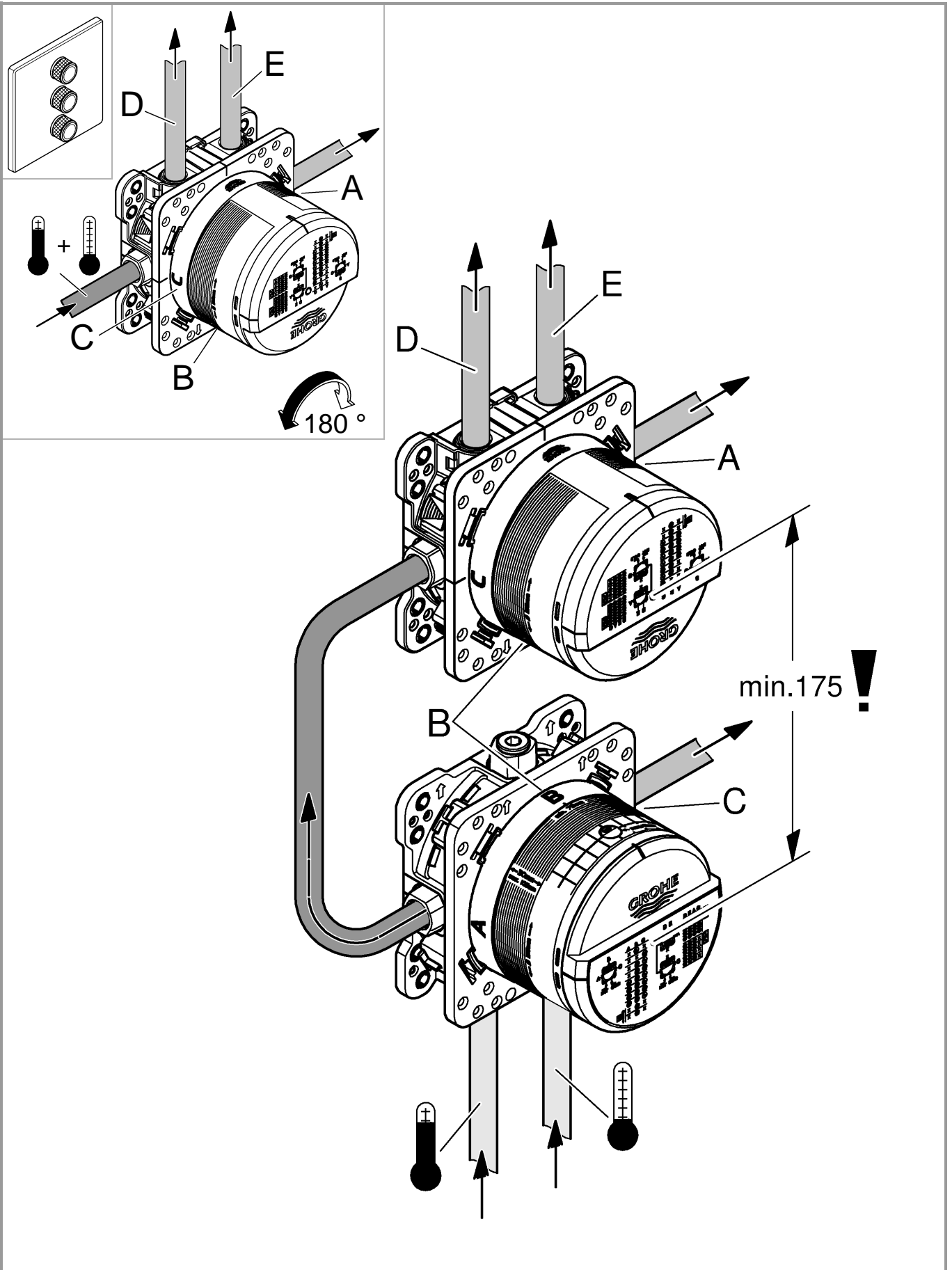

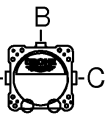

Grotherm SmartControl

	psi					
	14,5	29	43,5	58	72,5	87
D	3,2	4,5	5,5	6,4	7,2	7,8
E	3,2	4,5	5,5	6,4	7,2	7,8
A	3,2	4,5	5,5	6,4	7,2	7,8
C	4,4	6,3	7,7	8,8	9,9	10,8
D+E+A	4,4	6,3	7,7	8,8	9,9	10,8
D+E+A+C	5,5	7,8	9,5	11	12,3	13,4

gpm

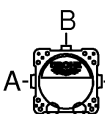
	bar					
	1	2	3	4	5	6
D	12,1	17,1	21	24,2	27,1	29,7
E	12,1	17,1	21	24,2	27,1	29,7
A	12,1	17,1	21	24,2	27,1	29,7
C	16,7	23,7	29	33,5	37,4	41
D+E+A	16,7	23,7	29	33,5	37,4	41
D+E+A+C	20,8	29,4	36	41,6	46,5	50,9

l/min

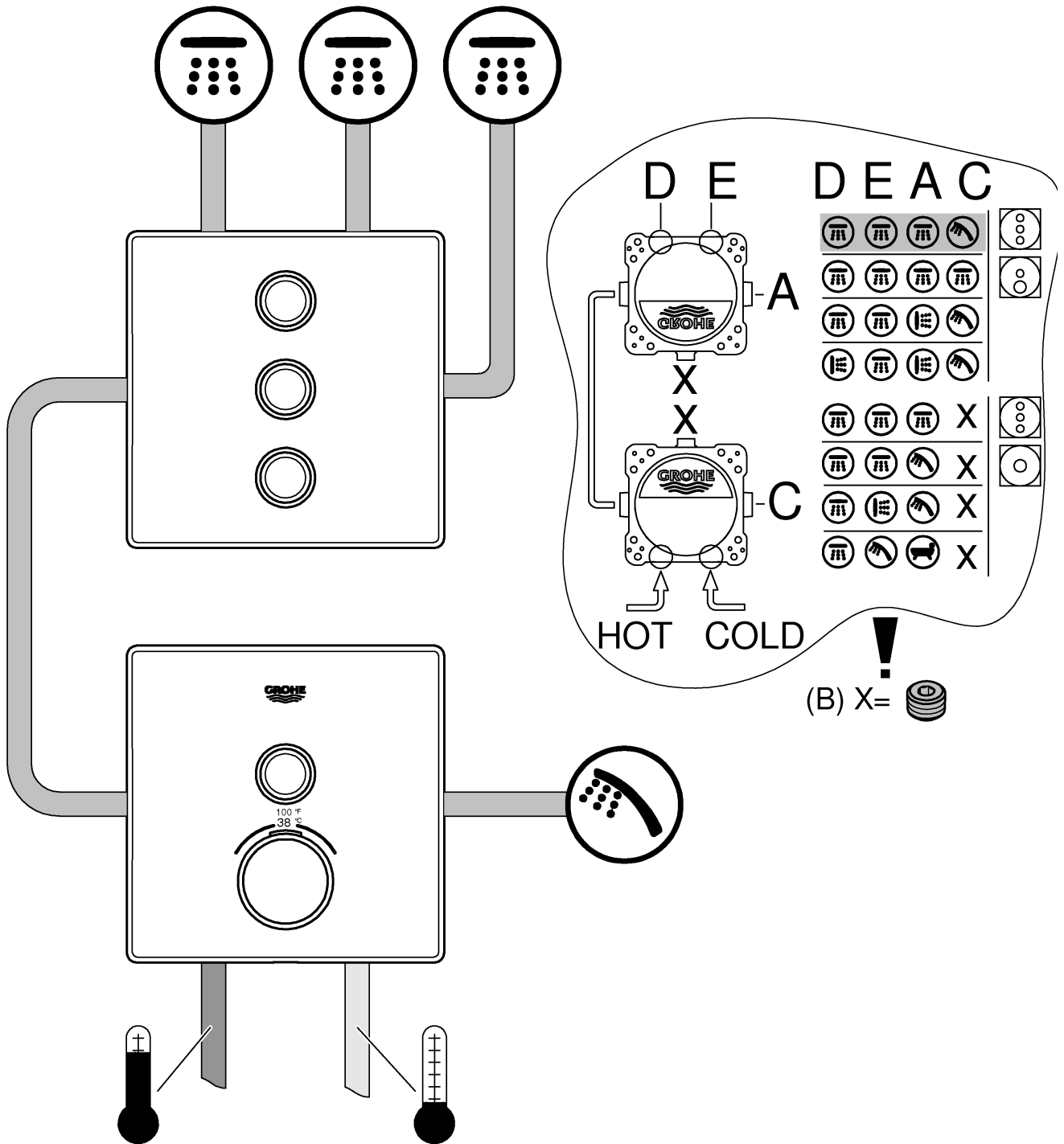



Grotherm SmartControl

A-B-C	psi						gpm
	14,5	29	43,5	58	72,5	87	
D	3,2	4,5	5,5	6,4	7,2	7,8	
E	3,2	4,5	5,5	6,4	7,2	7,8	
A	3,2	4,5	5,5	6,4	7,2	7,8	
C	4,4	6,3	7,7	8,8	9,9	10,8	
D+E+A	4,4	6,3	7,7	8,8	9,9	10,8	
D+E+A+C	5,5	7,8	9,5	11	12,3	13,4	

A-B-C	bar						l/min
	1	2	3	4	5	6	
D	12,1	17,1	21	24,2	27,1	29,7	
E	12,1	17,1	21	24,2	27,1	29,7	
A	12,1	17,1	21	24,2	27,1	29,7	
C	16,7	23,7	29	33,5	37,4	41	
D+E+A	16,7	23,7	29	33,5	37,4	41	
D+E+A+C	20,8	29,4	36	41,6	46,5	50,9	

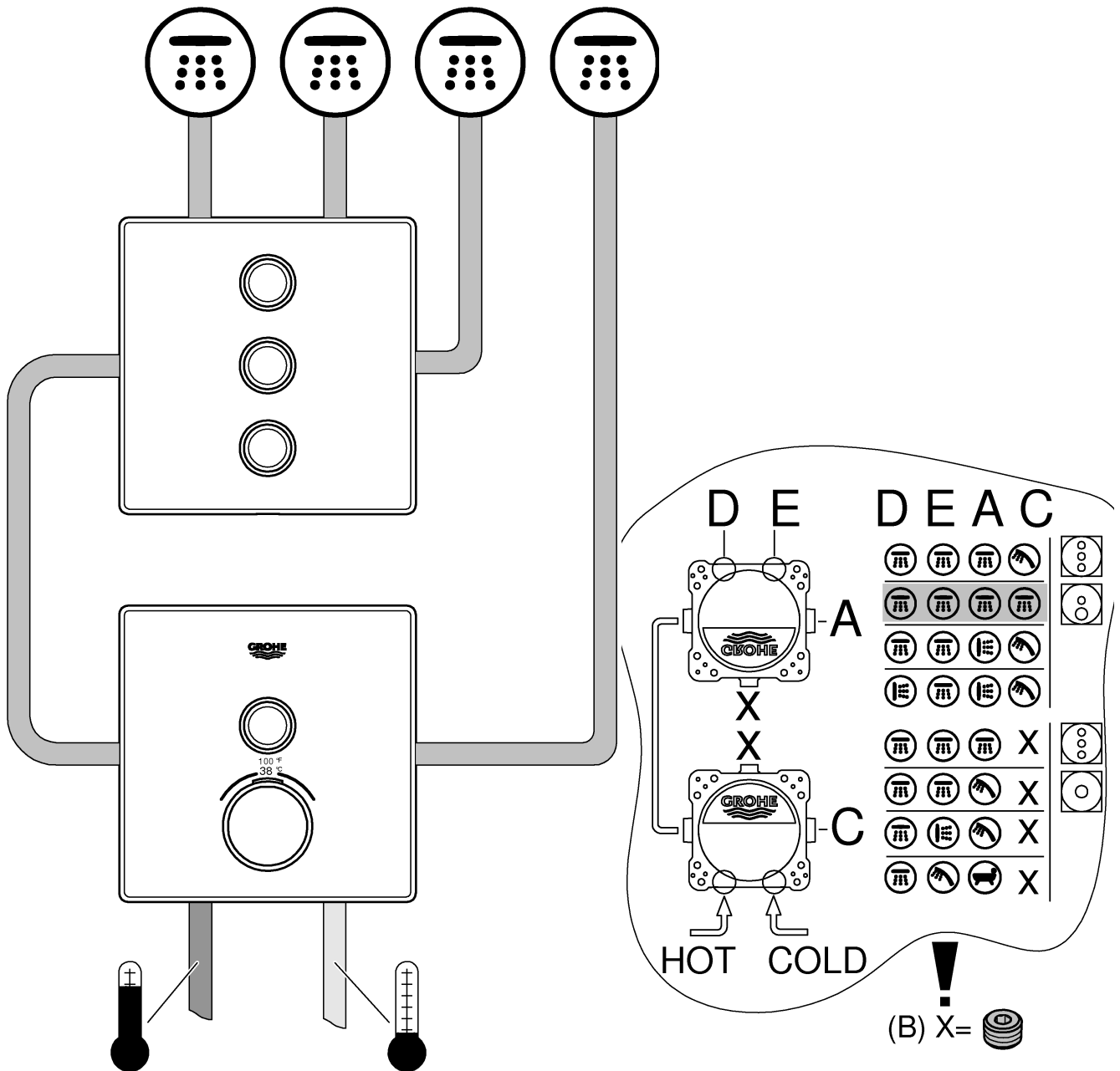



Grotherm SmartControl

A-B-C	psi					
	14,5	29	43,5	58	72,5	87
D	3,2	4,5	5,5	6,4	7,2	7,8
E	3,2	4,5	5,5	6,4	7,2	7,8
A	3,2	4,5	5,5	6,4	7,2	7,8
C	4,4	6,3	7,7	8,8	9,9	10,8
D+E+A	4,4	6,3	7,7	8,8	9,9	10,8
D+E+A+C	5,5	7,8	9,5	11	12,3	13,4

gpm

A-B-C	bar					
	1	2	3	4	5	6
D	12,1	17,1	21	24,2	27,1	29,7
E	12,1	17,1	21	24,2	27,1	29,7
A	12,1	17,1	21	24,2	27,1	29,7
C	16,7	23,7	29	33,5	37,4	41
D+E+A	16,7	23,7	29	33,5	37,4	41
D+E+A+C	20,8	29,4	36	41,6	46,5	50,9

l/min

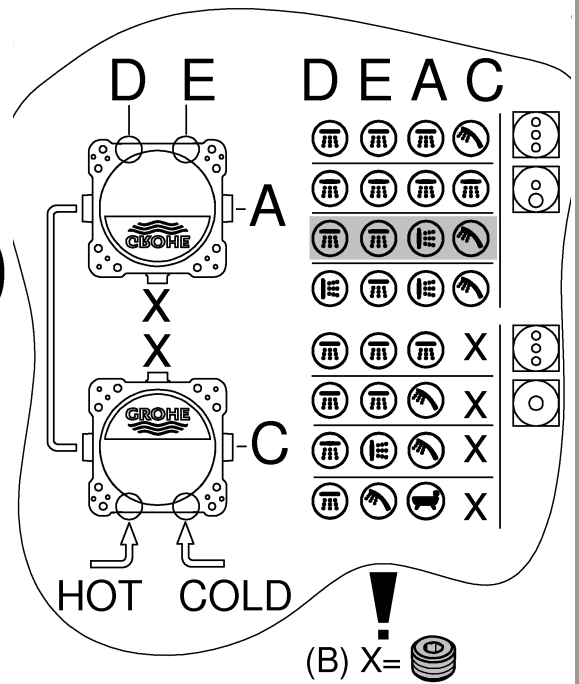
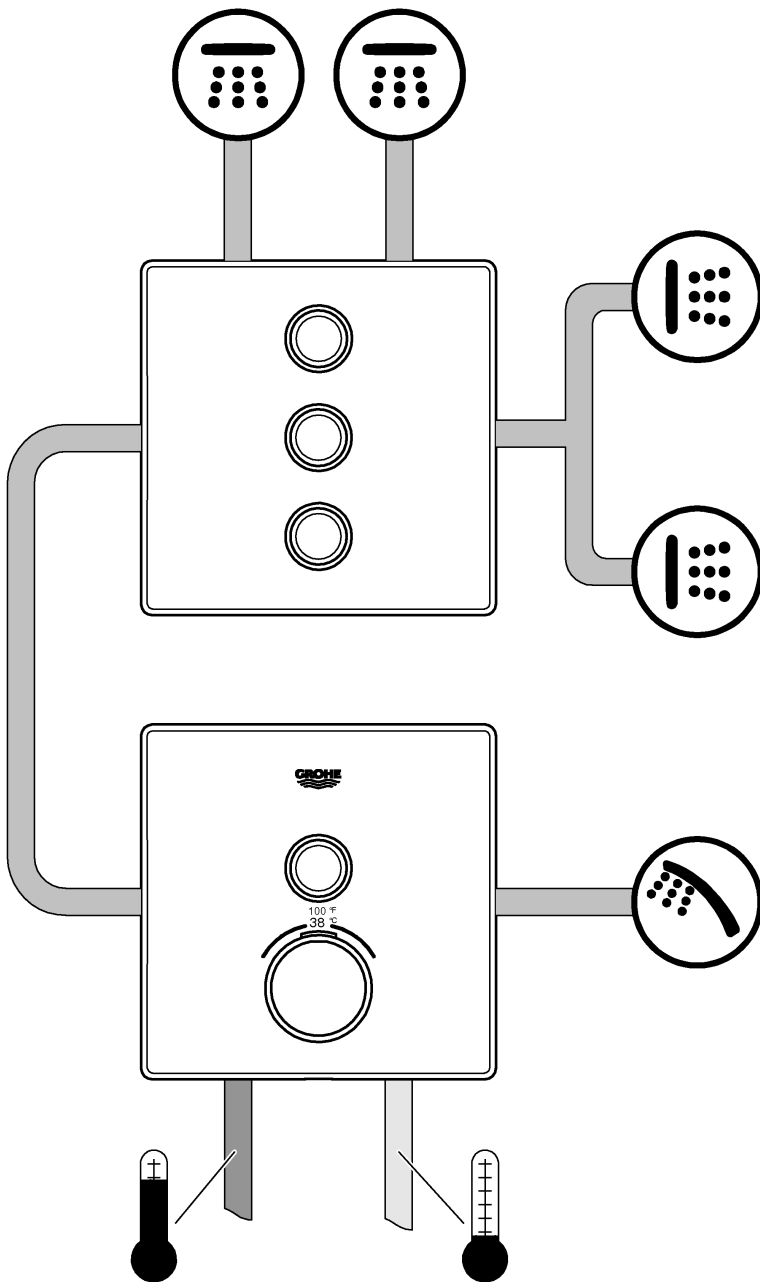

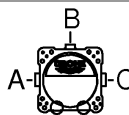

Grotherm SmartControl

	psi						gpm
	14,5	29	43,5	58	72,5	87	
D	3,2	4,5	5,5	6,4	7,2	7,8	
E	3,2	4,5	5,5	6,4	7,2	7,8	
A	3,2	4,5	5,5	6,4	7,2	7,8	
C	4,4	6,3	7,7	8,8	9,9	10,8	
D+E+A	4,4	6,3	7,7	8,8	9,9	10,8	
D+E+A+C	5,5	7,8	9,5	11	12,3	13,4	

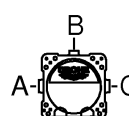
	bar						l/min
	1	2	3	4	5	6	
D	12,1	17,1	21	24,2	27,1	29,7	
E	12,1	17,1	21	24,2	27,1	29,7	
A	12,1	17,1	21	24,2	27,1	29,7	
C	16,7	23,7	29	33,5	37,4	41	
D+E+A	16,7	23,7	29	33,5	37,4	41	
D+E+A+C	20,8	29,4	36	41,6	46,5	50,9	

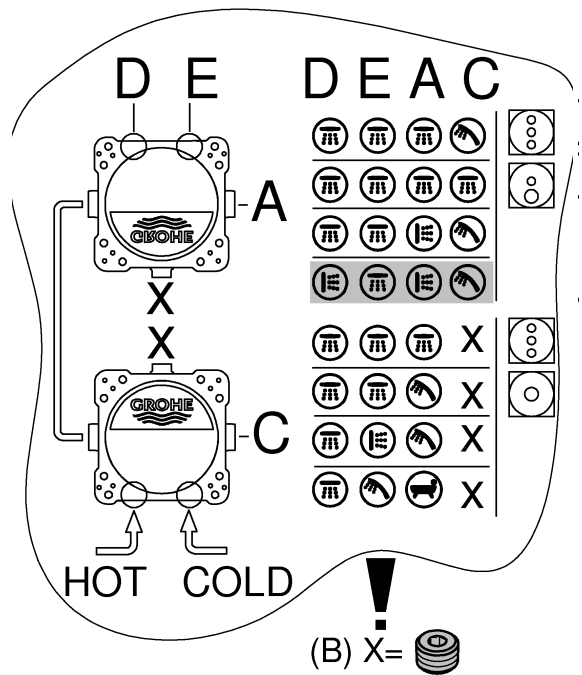
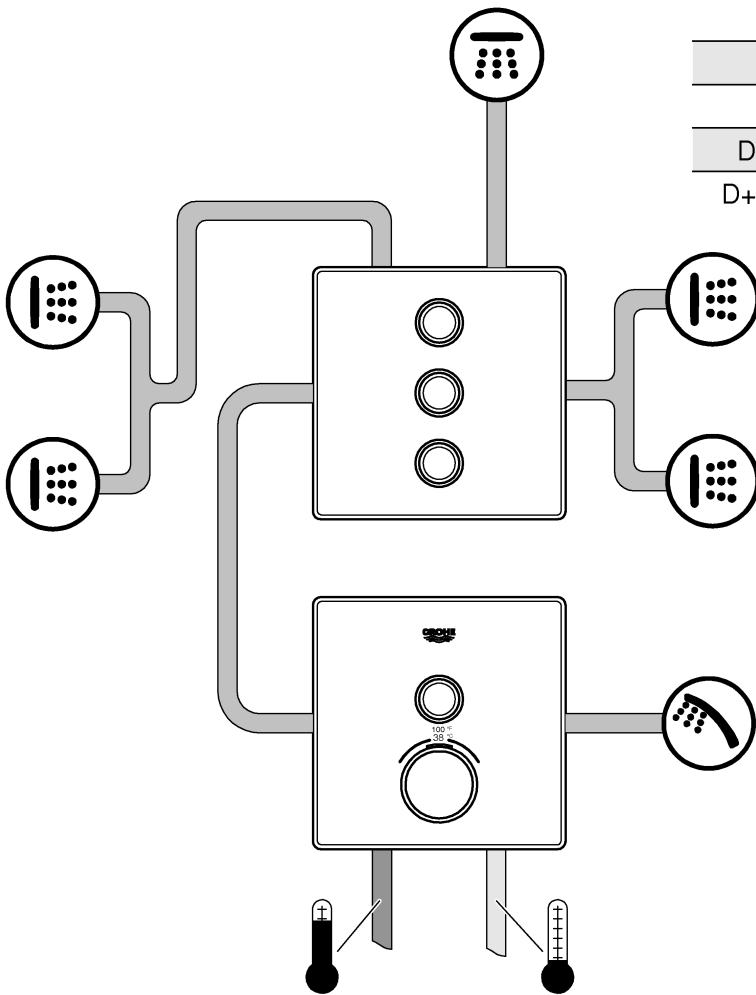

USA

Technical specifications Grohtherm 2-Handle Thermostat

- Flow pressure
 - Minimum flow pressure without downstream resistances 7.25 psi
 - Minimum flow pressure with downstream resistances 14.5 psi
 - Recommended 21.75-72.5 psi
- Minimum flow rate 1.3gpm
- Temperature
 - Hot water inlet max. 158 °F
 - Recommended for energy saving 140 °F
 - Thermal disinfection possible
- Hot water temperature at supply connection min. 3.6 °F higher than mixed water temperature

Flow rates without downstream resistances, see page 27-30. **These are to be observed when dimensioning the outlet!**

- Recommended configuration options, see from page 26-30.

The following special accessories are available:

- Extension 1" (prod. no.: 14 058)
- Service stops (prod. no.: 14 053)
- Reversed connection, hot on right – cold on left replace thermostat cartridges (prod. no.: 49 003)

F

Caractéristiques techniques Grohtherm 2-Handle Thermostat

- Pression dynamique
 - Pression dynamique minimale sans résistances en aval 0,5 bar
 - Pression dynamique minimale avec résistances en aval 1 bar
 - Recommandée 1,5 à 5 bars
- Débit minimal 5 l/min
- Température
 - Arrivée d'eau chaude max. 70 °C
 - Recommandée pour une économie d'énergie 60 °C
 - Désinfection thermique possible
- Température de l'eau chaude au raccord d'alimentation au moins 2 °C de plus que la température de l'eau mitigée

Débits sans résistances en aval, voir pages 27-30.

Veillez en tenir compte lors du dimensionnement de l'évacuation !

- Possibilités de configuration recommandées, voir à partir de la page 26-30.

Les accessoires spéciaux suivants sont disponibles :

- Rallonge de 25mm (réf. : 14 058)
- Robinets d'arrêt (réf. : 14 053)
- Raccordement inversé, chaud à droite - froid à gauche, remplacer la cartouche du thermostat (réf. : 49 003)

E

Datos técnicos de Grohtherm 2-Handle Thermostat

- Presión de trabajo
 - Presión mínima de trabajo sin resistencias posacopladas 7.25 psi
 - Presión mínima de trabajo con resistencias posacopladas 14.5 psi
 - Presión recomendada 21.75-72.5 psi
- Caudal mínimo 1.3gpm
- Temperatura
 - Entrada de agua caliente máx. 158 °F
 - Recomendada para ahorrar energía 140 °F
 - Desinfección térmica posible
- La temperatura del agua caliente en la acometida mín. 3.6 °F superior a la temperatura del agua mezclada

Caudales sin resistencias posacopladas, véanse las páginas 27-30. **Tenga en cuenta las dimensiones del desagüe.**

- Posibilidades de configuración recomendadas, véase a partir de la página 26-30.

Los siguientes accesorios opcionales están disponibles:

- Prolongación de 1" (n.º de pedido: 14 058)
- Bloqueos de seguridad (n.º de pedido: 14 053)
- Conexión invertida, derecha caliente - izquierda frío sustituir los cartuchos del termostato (n.º de pedido: 49 003)

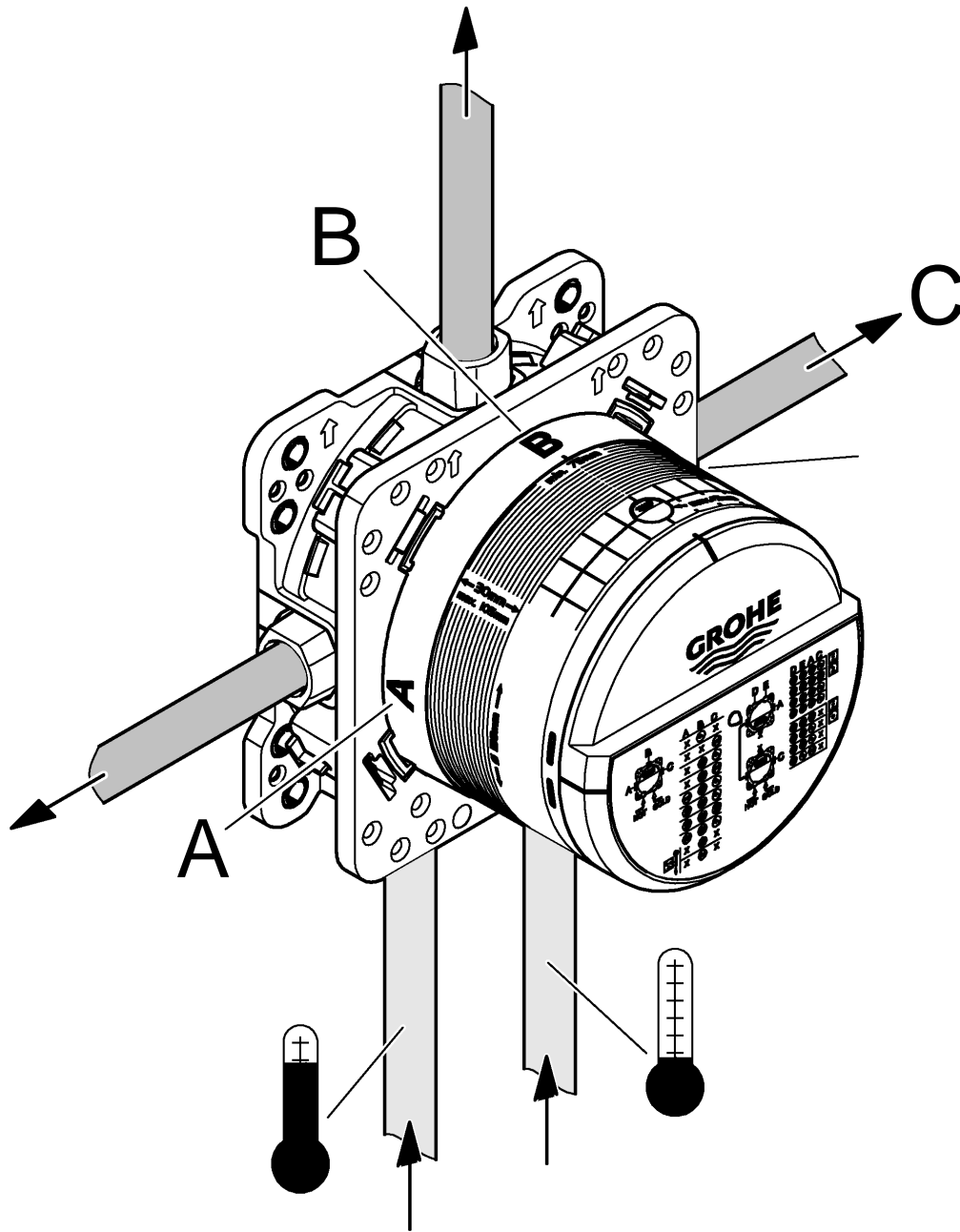



Grotherm 2-Handle Thermostat

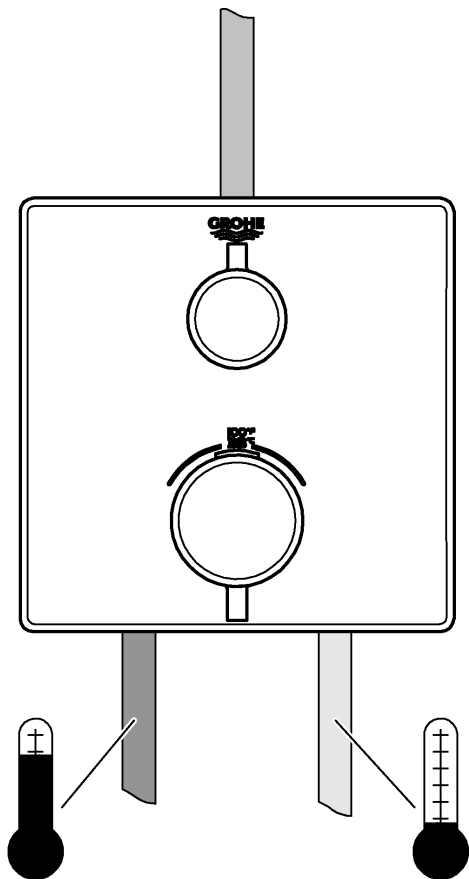
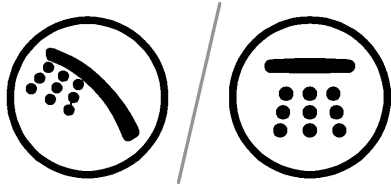

		psi						
A	B	C	14,5	29	43,5	58	72,5	87
			B	4,1	5,8	7,1	8,2	9,2

		bar						
A	B	C	1	2	3	4	5	6
			B	15,5	22	27	31,0	35

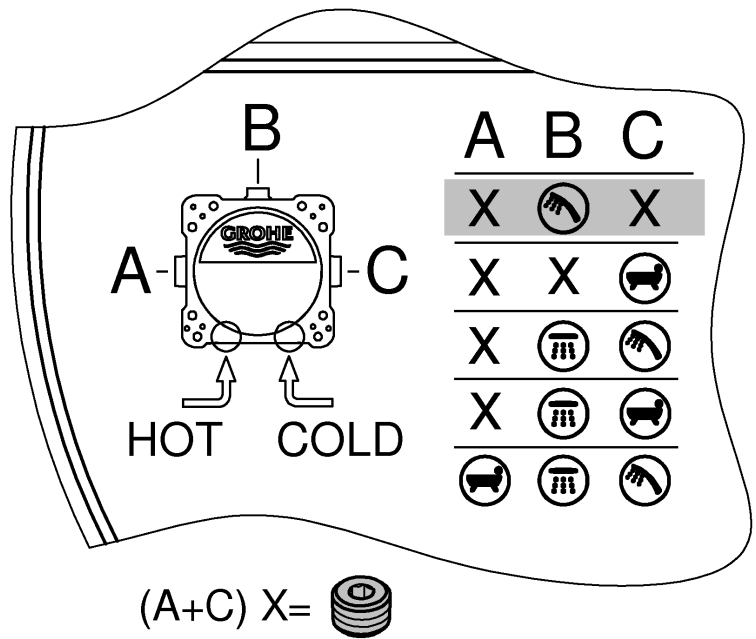



Grotherm 2-Handle Thermostat

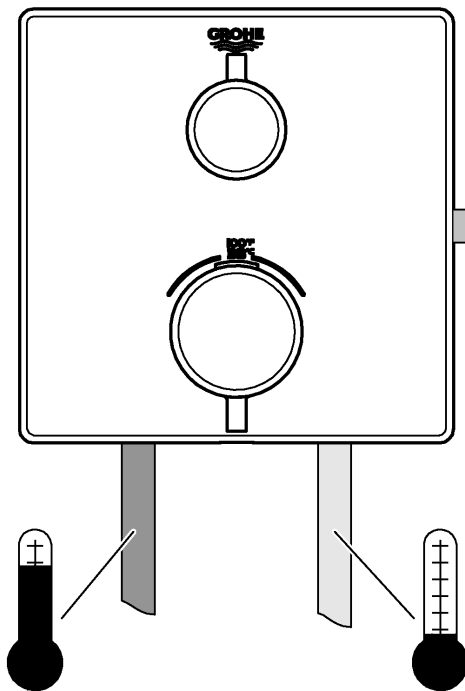

	psi						gpm
	14,5	29	43,5	58	72,5	87	
C	4,1	5,8	7,1	8,2	9,2	10	

	bar						l/min
	1	2	3	4	5	6	
C	15,5	22	27	31	35	38	

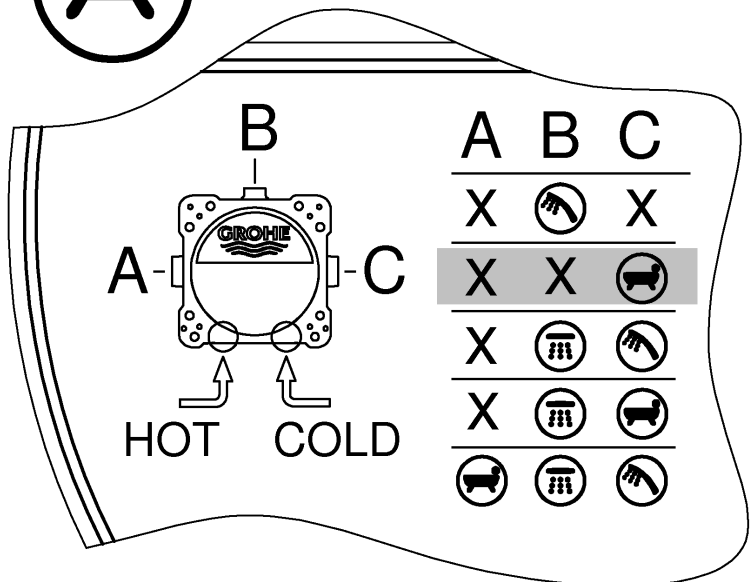

(A+B) X=



Grotherm 2-Handle Thermostat

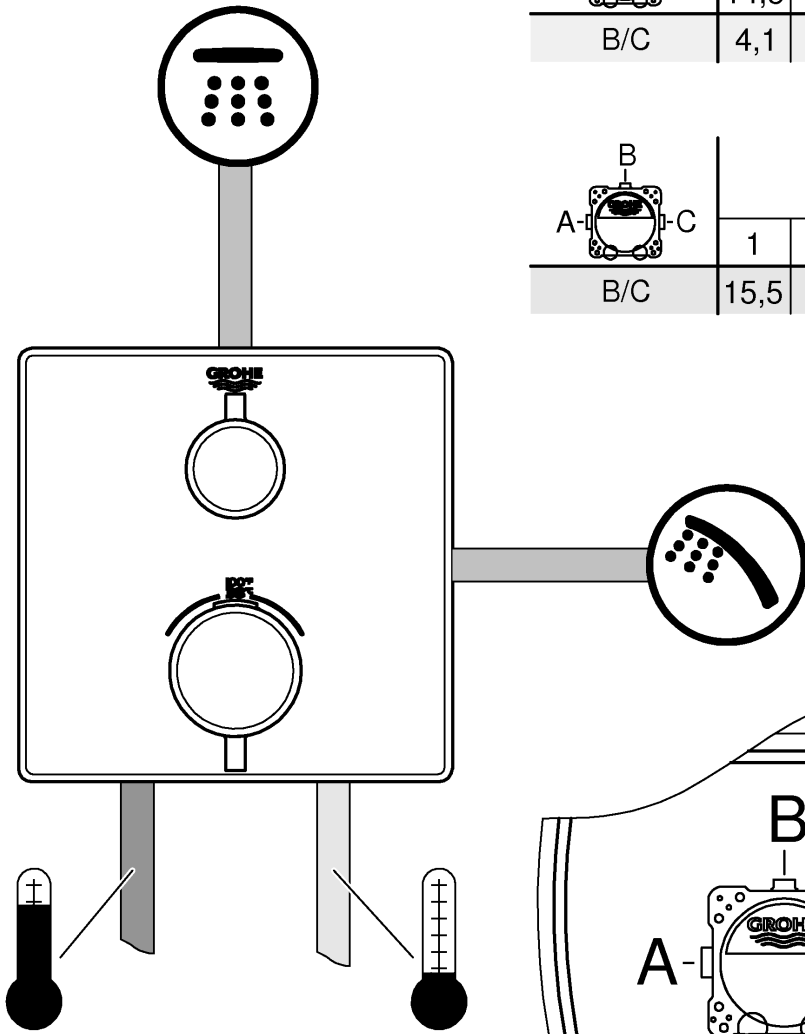

	psi						gpm
	14,5	29	43,5	58	72,5	87	
B/C	4,1	5,8	7,1	8,2	9,2	10,0	

	bar						l/min
	1	2	3	4	5	6	
B/C	15,5	22	27	31	35	38	

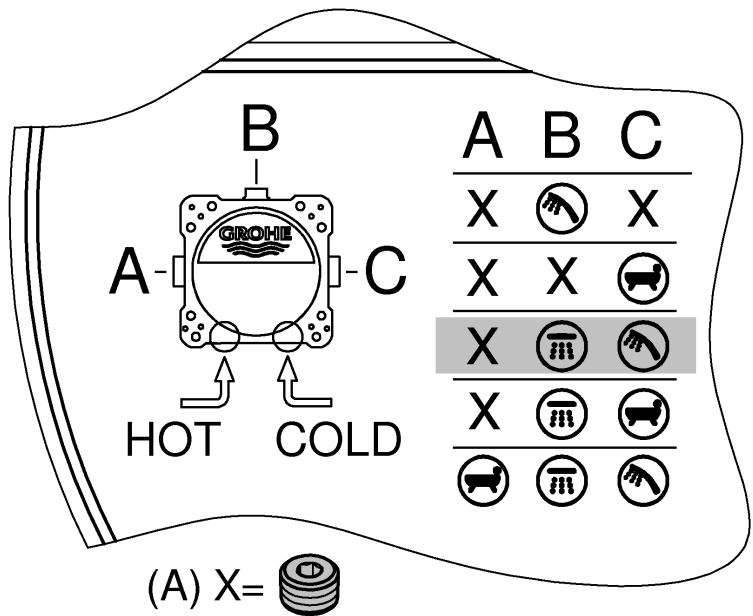



Grotherm 2-Handle Thermostat

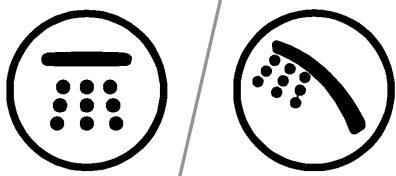

	psi						
	14,5	29	43,5	58	72,5	87	
B/C	4,1	5,8	7,1	8,2	9,2	10,0	gpm

	bar						
	1	2	3	4	5	6	
B/C	15,5	22	27	31	35	38	l/min

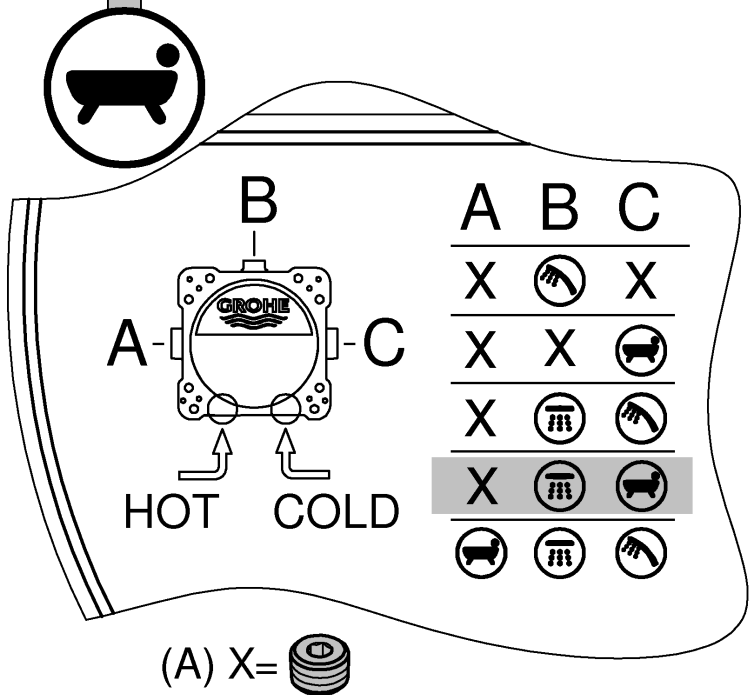
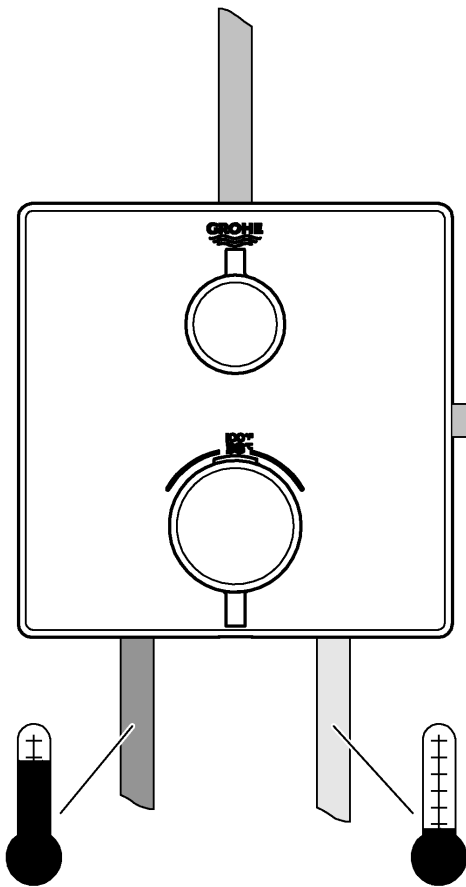

Pure Freude an Wasser

GROHE
WAVES

D

+49 571 3989 333
helpline@grohe.de

A

+43 1 68060
info-at@grohe.com

AUS

+(61) 1300 54945
grohe_australia@lixil.com

B

+32 16 230660
info.be@grohe.com

BG

+359 2 9719959
grohe-bulgaria@grohe.com

BR

0800 770 1222
falecom@grohe.com

CAU

+99 412 497 09 74
info-az@grohe.com

CDN

+1 888 6447643
info@grohe.ca

CH

+41 44 877 73 00
info@grohe.ch

CN

+86 4008811698
info.cn@grohe.com

CY

+357 22 465200
info@grome.com

CZ

+358 942 451 390
grohe-cz@grohe.com

DK

+45 44 656800
grohe@grohe.fi

E

+34 93 3368850
grohe@grohe.es

EST

+372 6616354
grohe@grohe.ee

F

+33 1 49972900
sav-fr@grohe.com

FIN

+358 942 451 390
grohe@grohe.fi

GB

+44 871 200 3414
info-uk@grohe.com

GR

+30 210 2712908
nsapountzis@ath.forthnet.gr

H

+36 1 2388045
info-hu@grohe.com

HK

+852 2969 7067
info@grohe.hk

I

+39 2 959401
info-it@grohe.com

IND

+91 1800 102 4475
customercare.in@grohe.com

IS

+354 515 4000
jonst@byko.is

J

+81 3 32989730
info@grohe.co.jp

KZ

+7 727 311 07 39
info-cac@grohe.com

LT

+372 6616354
grohe@grohe.ee

LV

+372 6616354
grohe@grohe.ee

MAL

info-malaysia@grohe.com

MX

01800 8391200
pregunta@grohe.com

N

+47 22 072070
grohe@grohe.no

NL

+31 79 3680133
vragen-nl@grohe.com

NZ

technicalenquiries@paterson
trading.co.nz

P

+351 234 529620
commercial-pt@grohe.com

PL

+48 22 5432640
biuro@grohe.com.pl

RI

0-800-1-046743
customercare-
indonesia@asia.lixil.com

RO

+40 21 2125050
info-ro@grohe.com

ROK

+82 2 1588 5903
info-singapore@grohe.com

RP

+63 2 8938681

RUS

+7 495 9819510
info@grohe.ru

S

+46 771 141314
grohe@grohe.se

SGP

+65 6311 3611
info-singapore@grohe.com

SK

+420 277 004 190
grohe-cz@grohe.com

T

+66 21681368
(Haco Group)
info@haco.co.th

TR

+90 216 441 23 70
GroheTurkey@grome.com

UA

+38 44 5375273
info-ua@grohe.com

USA

+1 800 4447643
us-customerservice@grohe.com

VN

+84 90 9694768
+84 90 9375068
info-vietnam@grohe.com

AL **BiH** **HR** **KS**

ME **MK** **SLO** **SRB**

+385 1 2911470
adria-hr@grohe.com

**Eastern Mediterranean,
Middle East - Africa
Area Sales Office:**

+357 22 465200
info@grome.com

IR **OM** **UAE** **YEM**

+971 4 3318070
grohedubai@grome.com

Far East Area Sales Office:

+65 6311 3600
info@grohe.com.sg

Latin America:

+52 818 3050626
pregunta@grohe.com

www.grohe.com

2016/09/28



26 632
27 489

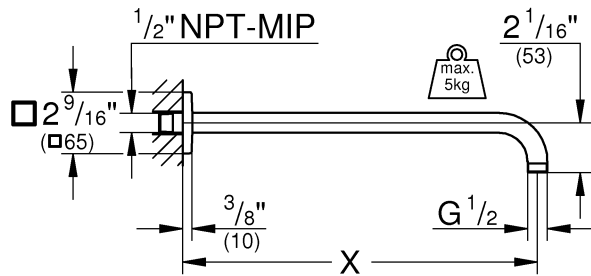

	X
26 632	14 3/4" (375)
27 489	10 13/16" (275)

26 633

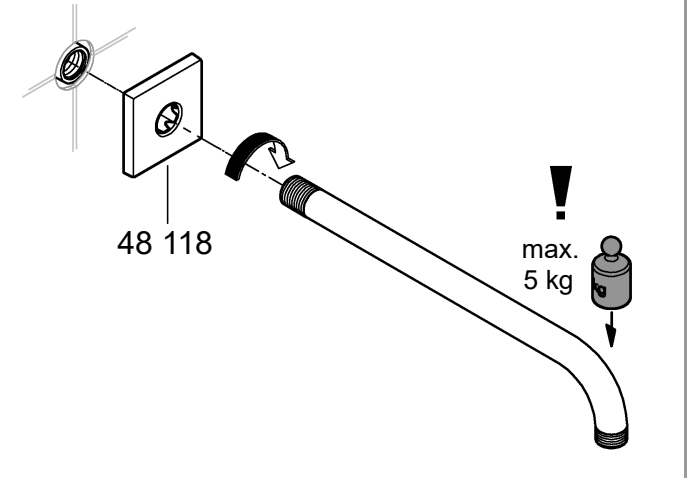
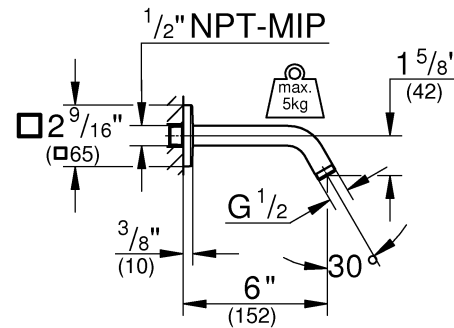

27 486
27 487

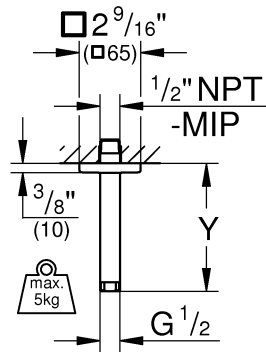

	Y
27 486	5 5/16" (135)
27 487	11 1/4" (285)

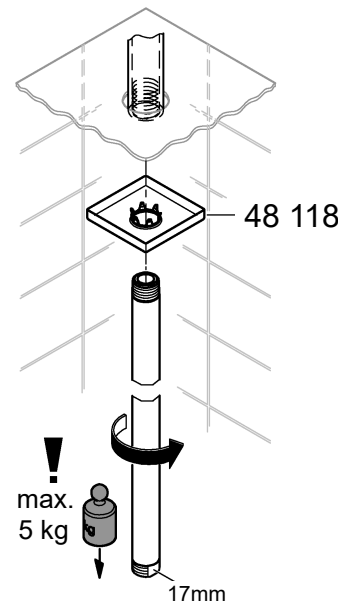

USA

When installing e.g. on plasterboard walls (not solid walls) it must be assured that an appropriate reinforcement is in place to ensure sufficient strength.

F

En cas de montage sur un support souple, une plaque de plâtre par ex., s'assurer que des renforts ont été montés sur le mur.

E

En el caso del montaje, por ejemplo en paredes de planchas de yeso (tabiques ligeros), debe asegurarse de que exista una firmeza suficiente mediante un refuerzo adecuado en la pared.



		<p>D</p> <p>Diese Kopfbrausen sollten nur in Verbindung mit Brausearm 27 484, 27 485, 27 488, 27 709 oder 27 711 verwendet werden!</p> <p>Bei Montage z.B. an Gipskartonwänden (keine feste Wand) muss sichergestellt sein, dass eine ausreichende Festigkeit durch eine entsprechende Verstärkung in der Wand vorhanden ist.</p> <p>5 Jahre Garantie auf die gleichbleibende Funktion der SpeedClean-Düsen. Durch die SpeedClean-Düsen, die regelmäßig gereinigt werden müssen, werden Kalkablagerungen am Strahlbildner durch einfaches Drüberstreichen entfernt, siehe Abb. [2].</p>	<p>GB</p> <p>These overhead showers should only be used in conjunction with shower arm 27 484, 27 485, 27 488, 27 709 or 27 711!</p> <p>When installing e.g. on plasterboard walls (not solid walls) it must be assured that an appropriate reinforcement is in place to ensure sufficient strength.</p> <p>The function of the SpeedClean nozzles is guaranteed for a period of five years. Thanks to the SpeedClean nozzles, which must be regularly cleaned, limescale deposits on the rose can be removed by simply rubbing with the fingers, see fig. [2].</p>	<p>F</p> <p>N'utiliser ces pommes de douche qu'avec les bras de douche 27 484, 27 485, 27 488, 27 709 ou 27 711!</p> <p>En cas de montage sur un support souple, une plaque de plâtre par ex., s'assurer que des renforts ont été montés sur le mur.</p> <p>Les buses SpeedClean sont garanties 5 ans.</p> <p>Les buses SpeedClean, qui doivent être nettoyées régulièrement, permettent d'éliminer, par frottement avec les doigts, les dépôts calcaires sur le diffuseur, voir fig. [2].</p>
<p>1</p>	<p>2</p>	<p>E</p> <p>¡Estas alcachofas de ducha solamente deben ser utilizadas junto con los brazos de ducha 27 484, 27 485, 27 488, 27 709 ó 27 711!</p> <p>En el caso del montaje, por ejemplo en paredes de planchas de yeso (tabiques ligeros), debe asegurarse de que exista una firmeza suficiente mediante un refuerzo adecuado en la pared.</p> <p>Los conos SpeedClean tienen 5 años de garantía de funcionamiento.</p> <p>Las boquillas SpeedClean deben limpiarse con regularidad y gracias a ellas los depósitos calcáreos que se hayan podido formar en el aro de salida se eliminan con un simple frotado, véase la fig. [2].</p>	<p>I</p> <p>Questi soffioni doccia dovrebbero essere utilizzati solo con il braccio 27 484, 27 485, 27 488, 27 709 o 27 711!</p> <p>Durante il montaggio per es. su pareti in cartongesso (parete non fissa) assicurarsi che vi sia adeguata stabilità grazie ad un rinforzo corrispondente nella parete.</p> <p>Garanzia di 5 anni sul funzionamento invariato degli ugelli SpeedClean.</p> <p>Grazie agli ugelli SpeedClean, che devono essere puliti regolarmente, i residui calcarei sul disco getti possono essere rimossi semplicemente passandovi sopra un dito, vedi fig. [2].</p>	<p>NL</p> <p>Deze hoofddouches mogen alleen in combinatie met douchearm 27 484, 27 485, 27 488, 27 709 of 27 711 worden gebruikt!</p> <p>Bij montage bijv. aan gipswanden (geen vaste wand) moet ervoor worden gezorgd, dat er voldoende stevigheid door een overeenkomstige versterking in de wand is.</p> <p>Wij verlenen 5 jaar garantie op het constant functioneren van de SpeedClean-sproeiers.</p> <p>Door de SpeedClean-sproeiers, die regelmatig moeten worden gereinigd, wordt kalkaanslag op de straalvormer door eenvoudig erover smeren verwijderd, zie afb. [2].</p>
	<p>USA</p> <p>These overhead showers should only be used in conjunction with shower arm 27 486, 27 487, 27 489, 27 710 or 27 712!</p> <p>When installing e.g. on plasterboard walls (not solid walls) it must be assured that an appropriate reinforcement is in place to ensure sufficient strength.</p> <p>The function of the SpeedClean nozzles is guaranteed for a period of five years. Thanks to the SpeedClean nozzles, which must be regularly cleaned, limescale deposits on the rose can be removed by simply rubbing with the fingers, see fig. [2].</p>	<p>S</p> <p>Dessa huvudduschar bör endast användas i kombination med duscharm 27 484, 27 485, 27 488, 27 709 eller 27 711!</p> <p>Vid montering t.ex. på gipsväggar (inte fast vägg), måste kontrolleras att tillräcklig hållfasthet garanteras av en förstärkning i väggen.</p> <p>5 års garanti för att SpeedClean-munstyckenas funktion förblir oförändrad.</p> <p>Tack vare SpeedClean-munstycken, som måste rengöras med jämna mellanrum, kan kalkavlagringar på strålmunstycket tas bort enkelt genom att stryka över det, se fig. [2].</p>	<p>DK</p> <p>Disse hovedbrusere bør kun anvendes i kombination med bruserarm 27 484, 27 485, 27 488, 27 709 eller 27 711!</p> <p>Ved montering på f.eks. vægge af gipsplader (ikke faste vægge) skal væggen være tilstrækkelig solid og derfor evt. forstærkes.</p> <p>5 års garanti på SpeedClean-dysernes funktion.</p> <p>SpeedClean-dyserne, der skal rengøres jævnligt, gør, at kalkaflejringer på stråleformeren ganske enkelt kan fjernes ved at tørre hen over dem, se ill. [2].</p>	<p>N</p> <p>Disse hodedusjene bør bare brukes i forbindelse med dusjarm 27 484, 27 485, 27 488, 27 709 eller 27 711!</p> <p>Ved montering på f.eks. gipsplater (ikke fast vegg), må man kontrollere at det er forsterkning i veggen.</p> <p>5 års garanti på stabil funksjon av SpeedClean-dyser.</p> <p>Med SpeedClean-dyser, som må rengjøres jevnlig, fjernes kalkavleiringer på perlatoren ved å gni over den, se bilde [2].</p>

<p>FIN</p> <p>Näitä yläsuihkuja tulee käyttää vain suihkuvarren 27 484, 27 485, 27 488, 27 709 tai 27 711 yhteydessä!</p> <p>Kun asennus tehdään esim. kipsilevyseiniiin (kevytrakenteinen seinä), seinässä täytyy olla riittävä vahvike pitävän kiinnityksen varmistamiseksi.</p> <p>SpeedClean-suuttimien toimintakyvyn säilymiselle myönnetään 5 vuoden takuu.</p> <p>Säännöllisesti puhdistettavien SpeedClean-suuttimien avulla kalkkikerrostumat poistetaan suihkunmuodostajasta yhdellä pyyhkäisyllä, ks. kuva [2].</p>	<p>PL</p> <p>Te górne glowice prysznicowe mogą być używane tylko z ramieniem prysznicza 27 484, 27 485, 27 488, 27 709 lub 27 711!</p> <p>W przypadku montażu np. na ścianach gipsowo-kartonowych (nie na ścianach stałych) należy zwiększyć wytrzymałość ściany przez wykonanie odpowiedniego wzmocnienia.</p> <p>5 lat gwarancji na niezawodne działanie dysz samooczyszczających SpeedClean.</p> <p>Dzięki dyszom SpeedClean, które należy regulować, osady wapienne z kształtownika strumienia można usunąć poprzez przetarcie jego powierzchni, zob. rys. [2].</p>	<p>UAE</p> <p>التركيب</p> <p>ينبغي عدم استخدام هذه الرشاش الرأسية إلا ارتباطاً مع ذراع الرشاة 27 484, 27 485, 27 488, 27 709 أو 27 711!</p> <p>عند التركيب على جدران الكرتون المخصصة على سبيل المثال (جدار غير ثابت) يجب التأكد من وجود ثبات كافي عن طريق تسليح مناسب في الجدار.</p> <p>نحن نضمن لك بقاء وظيفة منافذ التنظيف السريع SpeedClean بنفس مستوى الجودة لمدة 5 سنوات.</p> <p>يفضل منافذ التنظيف السريع SpeedClean يتم إزالة الترسبات الكلسية المتراكمة على فتحات تشكيل التدفق من خلال مسح فوقها بكل بساطة، انظر الشكل [2].</p>	<p>GR</p> <p>Αυτές οι κεφαλές ντους θα πρέπει να χρησιμοποιηθούν μόνον σε συνδυασμό με τους βραχιόνες ντους 27 484, 27 485, 27 488, 27 709 ή 27 711!</p> <p>Σε περίπτωση τοποθέτησης σε γυψοσανίδες (όχι σε σταθερή τοιχοποιία) θα πρέπει να φροντίσετε ώστε ο τοίχος να παρουσιάζει την απαιτούμενη αντοχή, π.χ. με κατάλληλη ενίσχυση.</p> <p>5 χρόνια εγγύηση για την αδιάκοπη λειτουργία των θηλών - Speed clean.</p> <p>Με τις θηλές SpeedClean, οι οποίες πρέπει να καθαρίζονται τακτικά, οι επικαθίσεις αλάτων ασβεστίου απομακρύνονται από το διαμορφωτή ψεκασμού με ένα απλό καθαρίσμα από πάνω, βλέπε εικ. [2].</p>	<p>CZ</p> <p>Tyto horní sprchy použijte pouze ve spojení s ramenem sprchy 27 484, 27 485, 27 488, 27 709 nebo 27 711!</p> <p>Při montáži např. na sádkartonové stěny (není pevná stěna) se musí zkontrolovat, zdali je odpovídajícím zesílením zajištěna dostatečná pevnost stěny.</p> <p>Na konstantní funkci trysek SpeedClean se poskytuje záruka 5 let. Usazeniny vodního kamene na regulátoru rozptylu paprsků lze odstranit jednoduchým přetřením povrchu trysek SpeedClean, vizzobr. [2]. Tyto trysky čistěte pravidelně.</p>	<p>H</p> <p>Ezt a fejuhany-rózsát csak a 27 484, 27 485, 27 488, 27 709 vagy 27 711 számú zuhanykarral együtt szabad alkalmazni!</p> <p>Gipszkarton falra (nem szilárd fal) történő szerelés esetén meg kell bizonyosodni arról, hogy a falba épített erősítő betét segítségével a megfelelő szilárdság biztosítható legyen.</p> <p>A SpeedClean fúvókákra 5 év garancia érvényes.</p> <p>A SpeedClean fúvókák révén, amelyeket rendszeresen tisztítani kell, a sugárképzőn keletkezett vízkölerakódások egyszerű, kézzel történő simítással eltávolíthatók, lásd a [2]-as ábrát.</p>
<p>P</p> <p>Estes chuveiros à parede deverão ser utilizados apenas com os braços para duche 27 484, 27 485, 27 488, 27 709 ou 27 711!</p> <p>Se a montagem for feita em paredes ligeiras (placas de gesso por exemplo), é necessário assegurar uma suficiente fixação na parede através de um reforço.</p> <p>5 anos de garantia de manutenção de um funcionamento igual dos orifícios de saída SpeedClean.</p> <p>Através das saídas SpeedClean, as quais têm de ser limpas regularmente, os depósitos de calcário no formador do jacto de água são eliminados com uma simples passagem da mão, ver fig. [2].</p>	<p>TR</p> <p>Tepe duşları 27 484, 27 485, 27 488, 27 709 veya 27 711 kodlu çıkış dirsekleri ile birlikte kullanılmalıdır!</p> <p>Örn. alçı duvarlara (sabit duvar değil) yapılacak montajda, duvarın uygun takviyeyle yeterli ölçüde sağlamlştırıldığından emin olunmalıdır.</p> <p>SpeedClean çıkışları 5 sene garanti kapsamındadır.</p> <p>Düzenli olarak temizlenmesi gereken, SpeedClean-uçları sayesinde kireç tabakalarını temizlemek için parmağınızı duşun üzerinden geçirmeniz yeterlidir, bkz. şekil [2].</p>	<p>SK</p> <p>Tieto horné sprchy použite len v spojení s ramenom sprchy 27 484, 27 485, 27 488, 27 709 alebo 27 711!</p> <p>Pri montáži napr. na sádkartónové steny (nie je pevná stena) sa musí skontrolovať, či je odpovedajúcim vystužením zaisťená dostatočná pevnosť steny.</p> <p>Na konštantnú funkciu trysiiek SpeedClean sa poskytuje záruka 5 rokov.</p> <p>Vápenaté usadeniny na regulátore rozptylu prúdu sa dajú odstrániť jednoduchým pretretím povrchu trysiiek SpeedClean, ktoré je potrebné pravidelne čistiť, pozri obr. [2].</p>	<p>SLO</p> <p>Ti razpršilci za prho se naj uporabljajo samo v kombinaciji z modeli 27 484, 27 485, 27 488, 27 709 ali 27 711!</p> <p>Pri montaži na suhomontažne stene, (gips in podobno), je potrebno uporabiti ustrezne montažne elemente, ki zagotavljajo potrebno trdnost stene.</p> <p>5-letna garancija za nespremenjeno delovanje šob SpeedClean.</p> <p>Šobe SpeedClean, ki jih je treba redno čistiti, omogočajo, da nabrani vodni kamen z glave razpršilnika odstranite tako, da preprosto potegnete čeznje, glej sliko [2].</p>	<p>HR</p> <p>Ove tuševe iznad glave trebalo bi koristiti samo u spoju sa rukom tuša 27 484, 27 485, 27 488, 27 709 i 27 711!</p> <p>Pri postavljanju npr. na zid iz od gips-kartona (brz čvrstog zida) mora se osigurati dostatna dovoljna čvrstoća postavljanjem odgovarajućeg odgovarajućeg ojačanja u zidu.</p> <p>Petogodišnje jamstvo na za nepromijenjenu funkcijubespriječerno funkcioniranje SpeedClean-sapnica. Pomoću SpeedClean-sapnica, koje se moraju redovito čistiti, mogu se odstraniti talozi vapnenca na oblikovniku mlaza, tako da se jednostavno prebrišu, pogledaj sl. [2].</p>	<p>BG</p> <p>Тези душеве за глава трябва да се използват само в комбинация със съединително коляно Кат.№ 27 484, 27 485, 27 488, 27 709 или 27 711!</p> <p>При монтаж напр. върху стени от гипскартон (не твърди стени) трябва да се осигури достатъчна здравина чрез съответно подсилване на стената.</p> <p>5 години гаранция за функционирането на дюзите - SpeedClean.</p> <p>С помощта на дюзите SpeedClean, които трябва редовно да се почистват, отлагания от варовик по струйника се отстраняват лесно чрез избърсване с ръка, виж фиг. [2].</p>
<p>EST</p> <p>Neid peadušše saab kasutada vaid koos dušikonsoolidega 27 484, 27 485, 27 488, 27 709 või 27 711!</p> <p>Paigaldamisel nt kipsseinale (mitte kindlale seinale) tuleb kõigepealt teha kindlaks, et sein oleks teatud piisavalt vastupidavaks vastava tugevduse abil seinas.</p> <p>SpeedClean-düüside muutmatu töötamise garantiiajaks on 5 aastat. SpeedClean-düüside kaudu, mida tuleb korrapäraselt puhastada, saab dušipihustit lubjasetet eemaldada lihtsa ülepühkimise teel, vt joonis [2].</p>	<p>LV</p> <p>Šīs augšējās dušas vajadzētu lietot komplektā ar dušas rokuri 27 484, 27 485, 27 488, 27 709 vai 27 711!</p> <p>Montējot, piemēram, pie ģipškartona sienām (siena nav monolīta) jāpārlicinās, lai sienā būtu pietiekoši stiprs, atbilstošs nostiprinājums.</p> <p>SpeedClean sprauslu darbam tiek dota 5 gadu garantija.</p> <p>Kaļķu nogulsņņumus no strūklas veidotāja var viegli notīrīt, paberzējot Speed Clean sprauslas, kas regulāri jātīra, skat. attēlu [2].</p>	<p>LT</p> <p>Šios dušo galvutės turi būti naudojami tik su dušo rankena Nr. 27 484, 27 485, 27 488, 27 709 arba 27 711!</p> <p>Montuojant dušą, pvz., prie gipsinių (netvirtų) sienų, būtina patikrinti, ar ji pakankamai sustiprinta.</p> <p>„SpeedClean“ purkštukams suteikiama 5 metų nuolatinio veikimo garantija. Dušo galvutės dugne yra įtaisyti „SpeedClean“ palengvina dušo, kurį reikia valyti reguliariai, priežiūra. Pakanka per dušo galvutės skylutes perbraukti ranka ir nuo jų nubyrés susidariusios kalkių nuosėdos, žr. pav. [2].</p>	<p>RO</p> <p>Aceste duşuri de cap trebuie folosite numai cu braţul de duş 27 484, 27 485, 27 488, 27 709 sau 27 711!</p> <p>La montarea pe pereţi din rigips (pereţi fără rigiditate), de exemplu, trebuie să se asigure o rigiditate suficientă printr-o consolidare corespunzătoare pe perete.</p> <p>5 ani garanţie pentru funcţionarea stabilă a duzelor SpeedClean.</p> <p>Prin duzele cu spălare rapidă (SpeedClean), care trebuie să fie curăţate regulat, pot fi înlăturate prin simplă frecare depunerile de piatră de pe formatorul de jet; a se vedea fig. [2].</p>	<p>CN</p> <p>安裝</p> <p>这些头顶花洒只能与淋浴支架 27 484, 27 485, 27 488, 27 709 或 27 711 一同连接使用!</p> <p>如果在石膏墙面（而非实体墙）上安装，务必进行必要的加固以确保有足够的支撑力。</p> <p>快速清洁 (SpeedClean) 喷嘴功能正常工作的保证期为 5 年。</p> <p>由于采用快速清洁 (SpeedClean) 喷嘴 (必须定期清洁)，喷雾器喷嘴上的钙质沉积可以用手指直接擦去 参见图 [2]。</p>	<p>RUS</p> <p>Эти верхние души следует использовать только с душевыми кронштейнами 27 484, 27 485, 27 488, 27 709 или 27 711!</p> <p>При монтаже, например, на стенах из гипсокартона (не обладающих прочностью) необходимо удостовериться, что достаточная прочность обеспечена за счет соответствующего усиления стены.</p> <p>5 лет гарантии на неизменное функционирование быстро очищаемых форсунок.</p> <p>Благодаря форсунам быстрого очищения SpeedClean, которые необходимо периодически чистить, известковые отложения на формирователе струй удаляются простым вытиранием, см. рис. [2].</p>

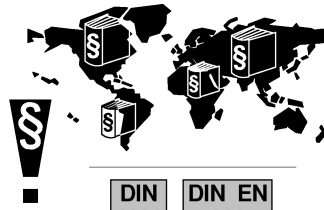

DIN
1988

DIN EN
806

26 634

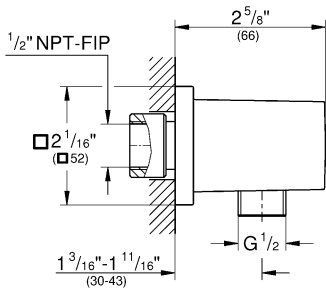

27 704

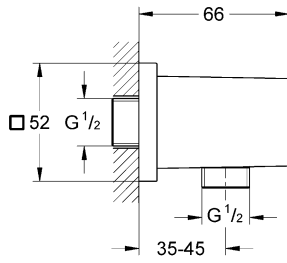

27 707

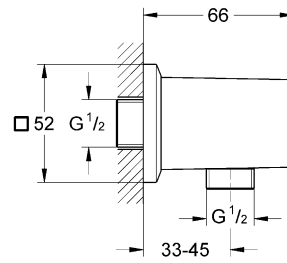

27 708

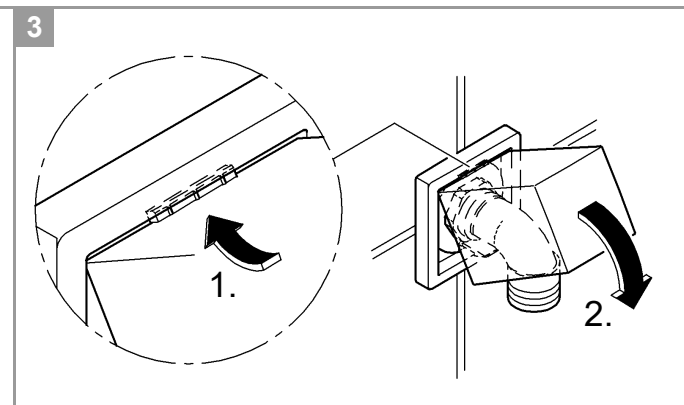
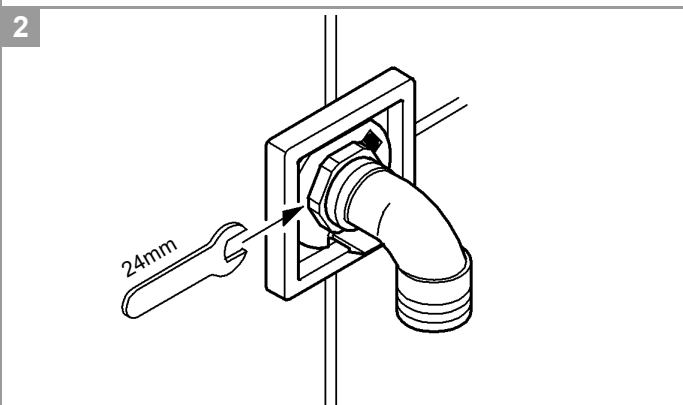
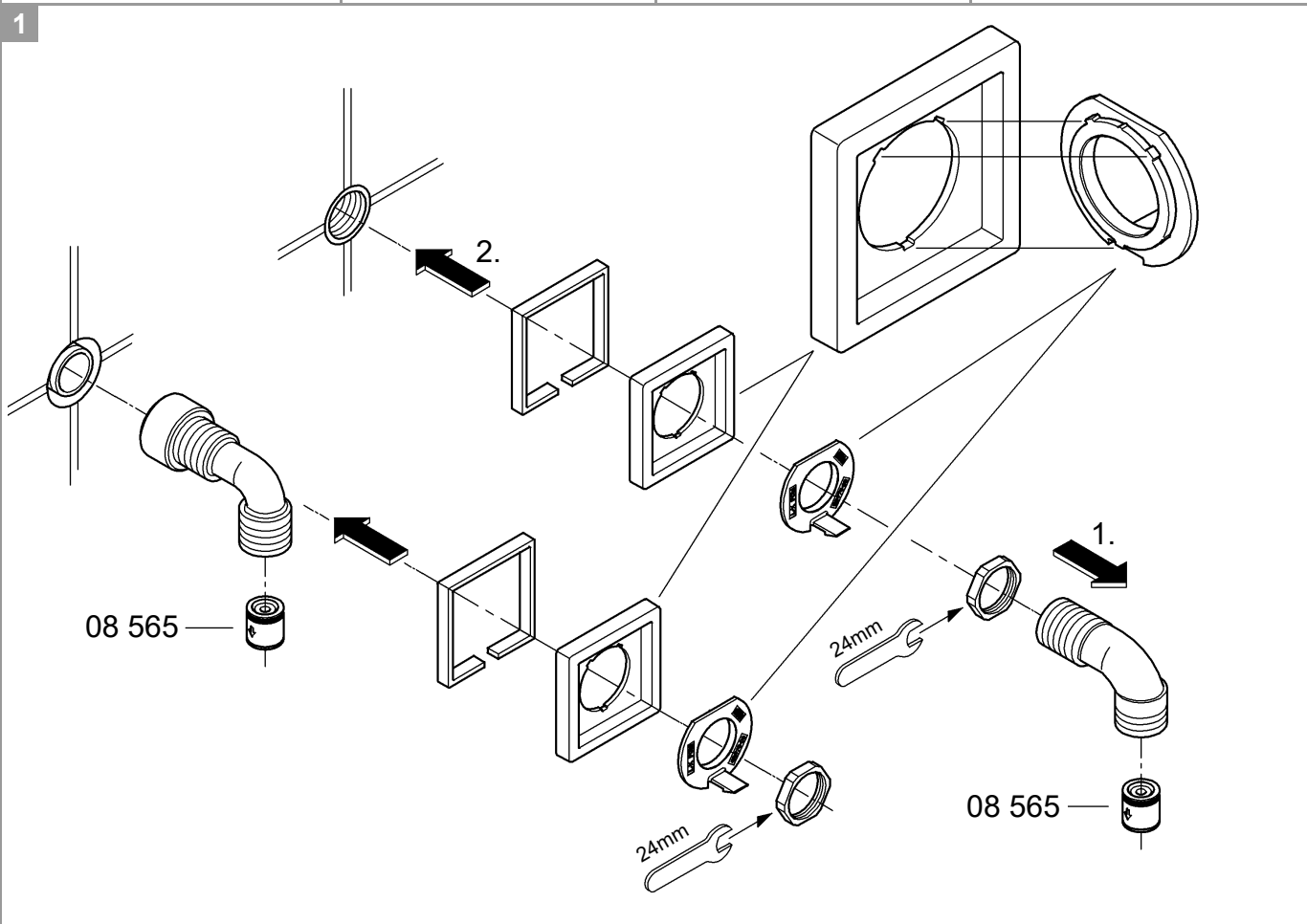
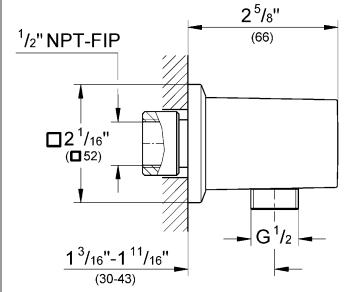

26 396
27 693

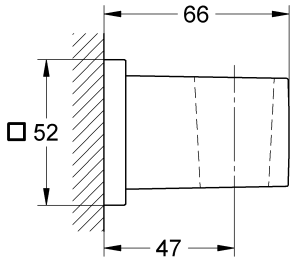

27 706

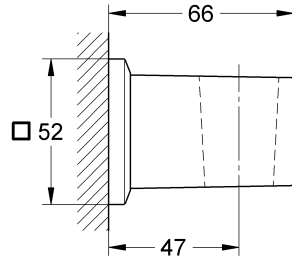

26 370

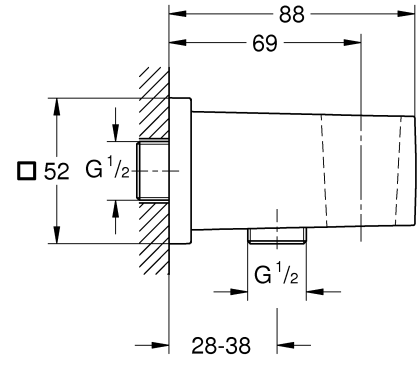

26 396
27 693
27 706

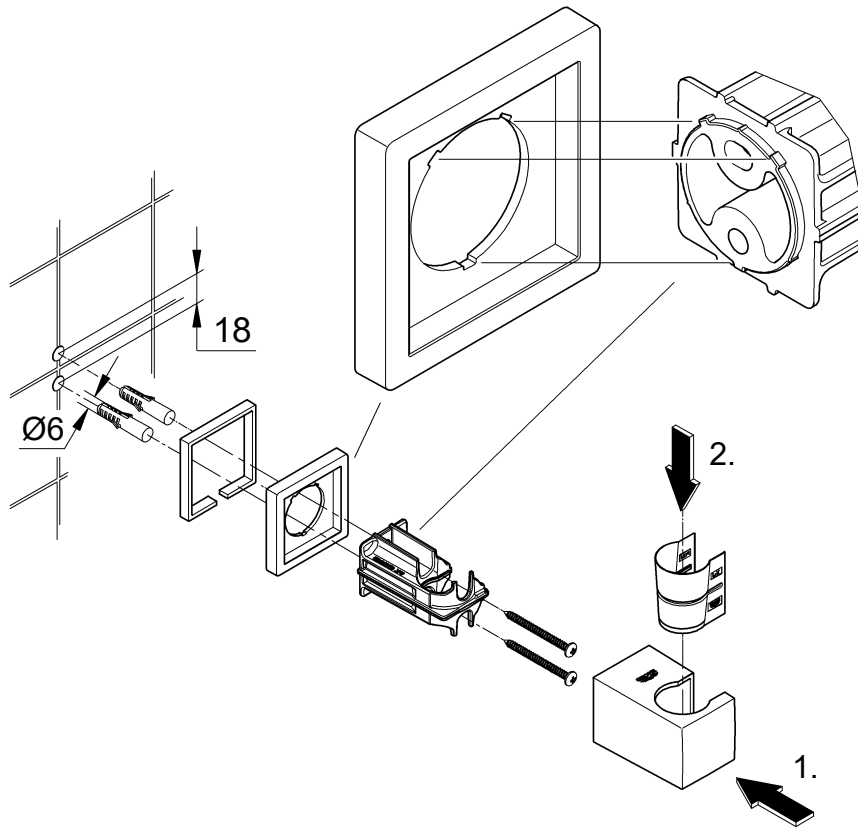

1

26 370

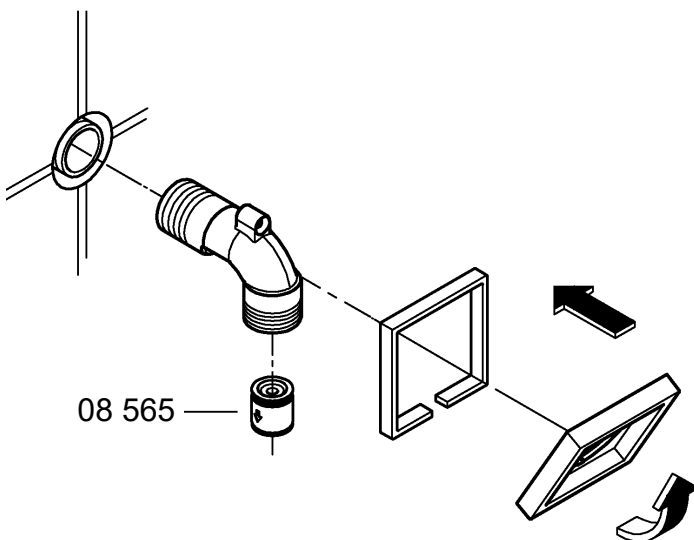

2

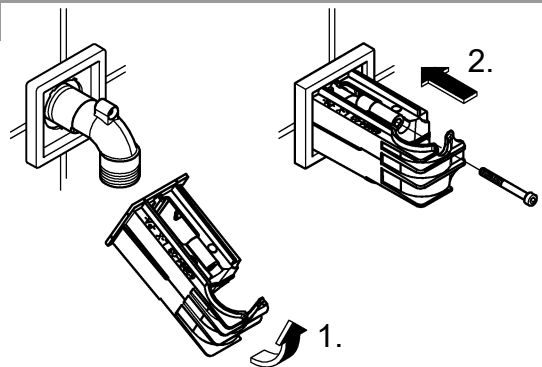

3

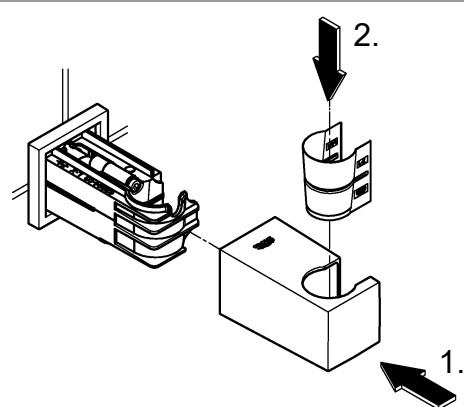

26 396
27 693

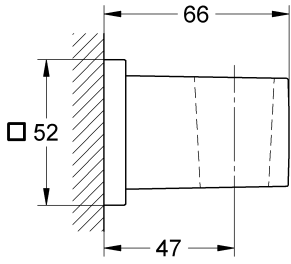

27 706

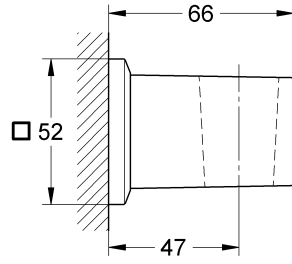

26 370

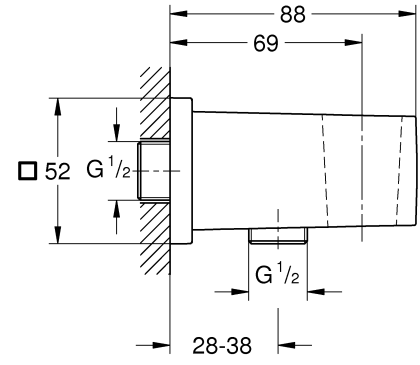

26 396
27 693
27 706

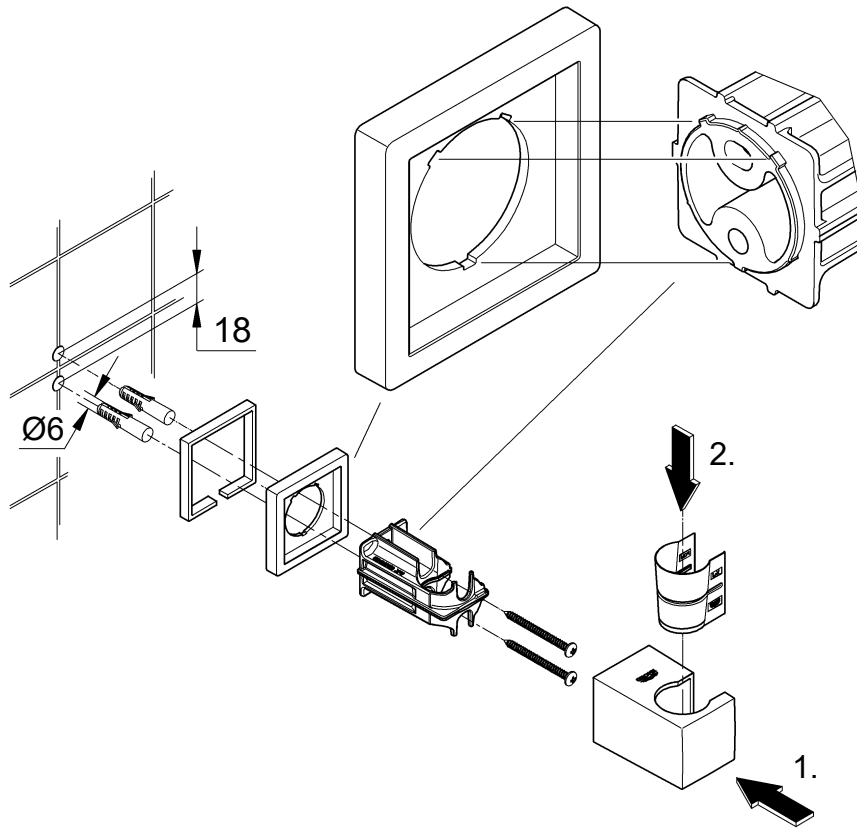

1

26 370

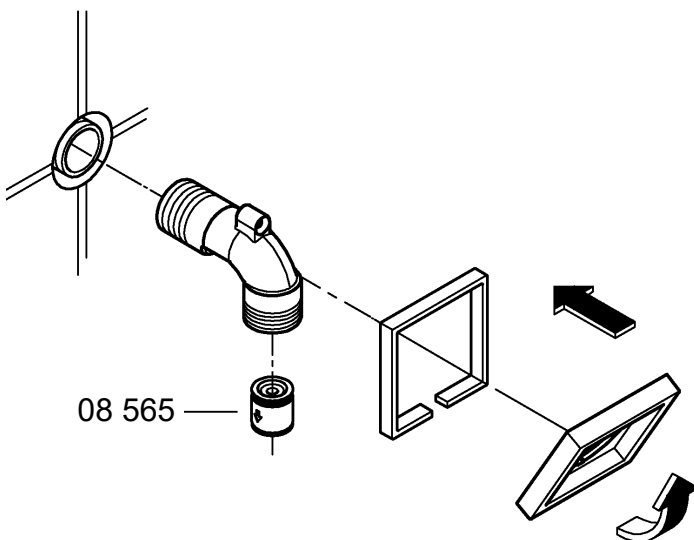

2

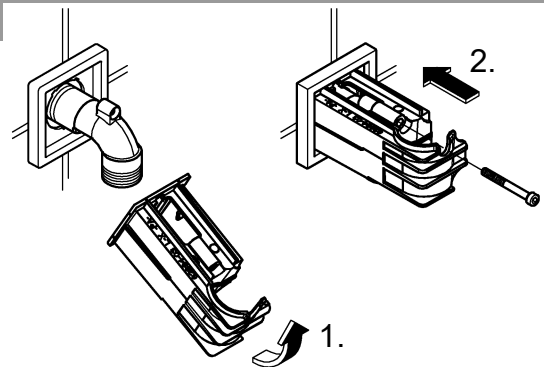

3

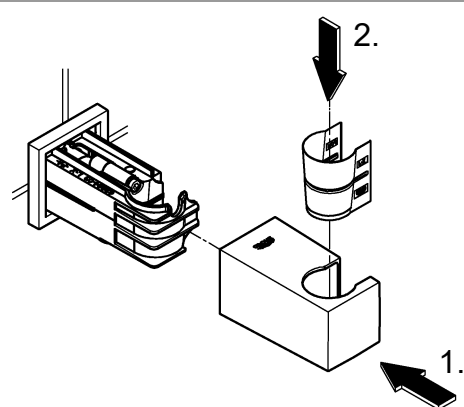

13 305

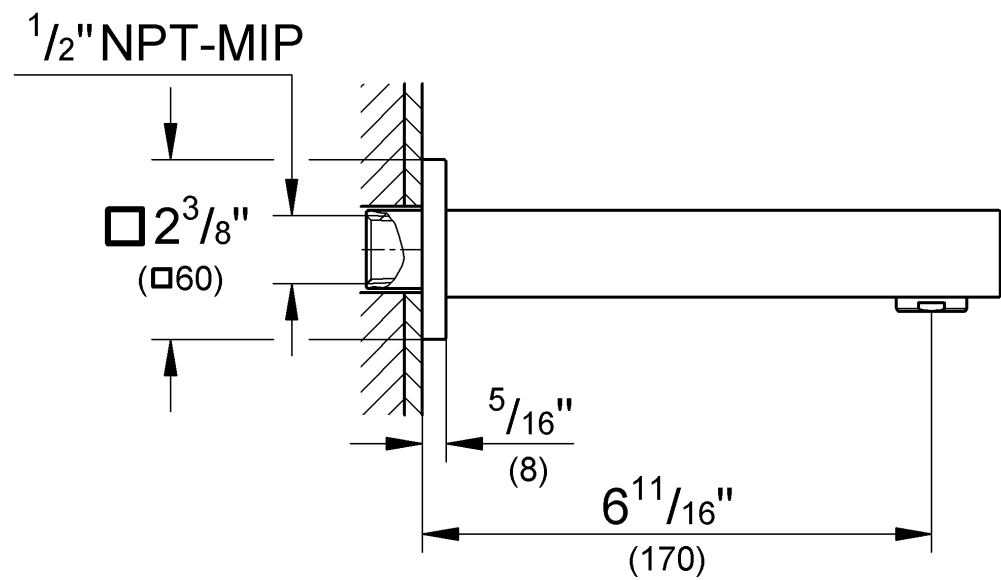

13 307

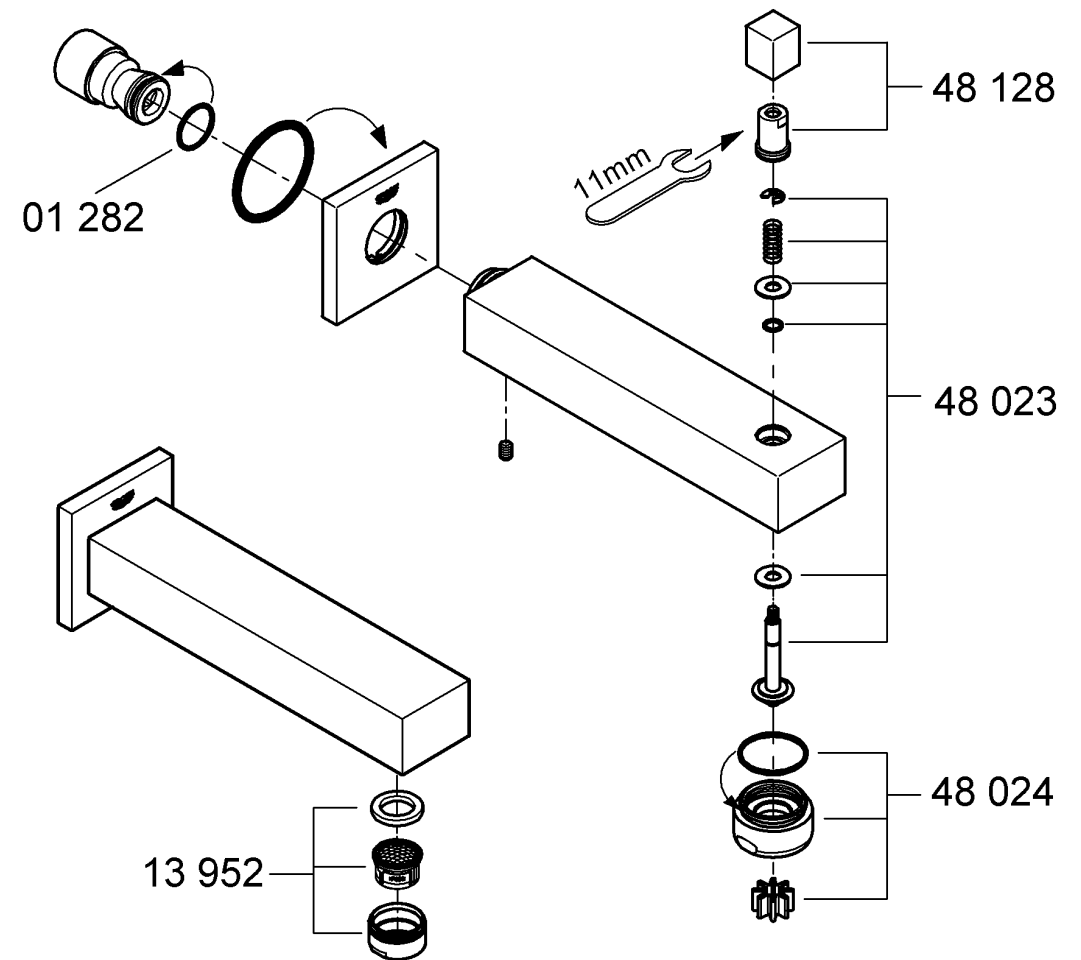
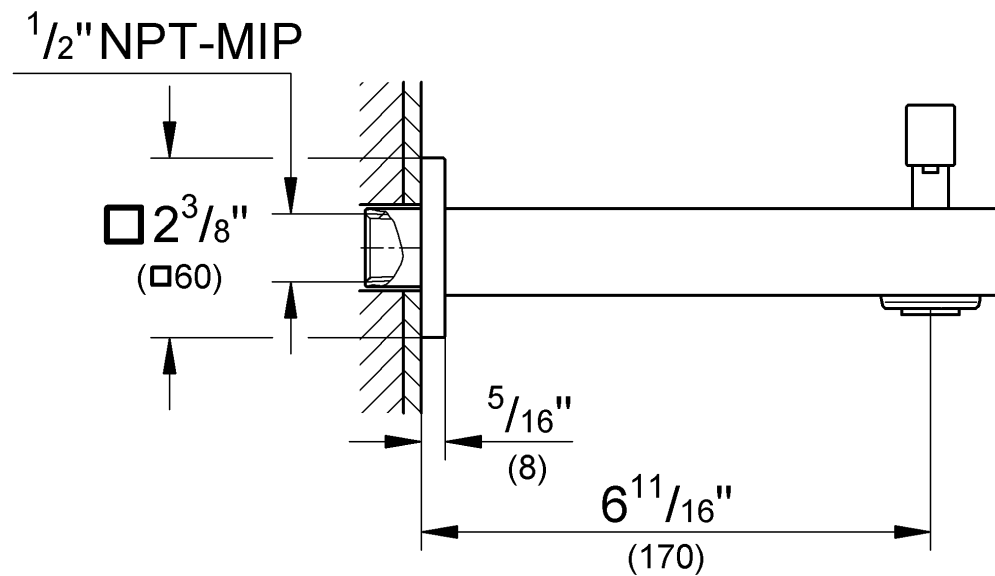

1.

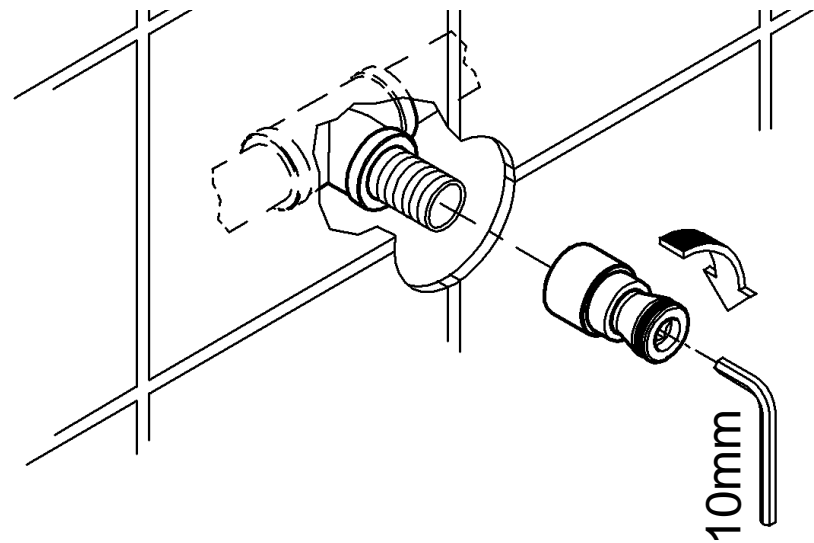

3.

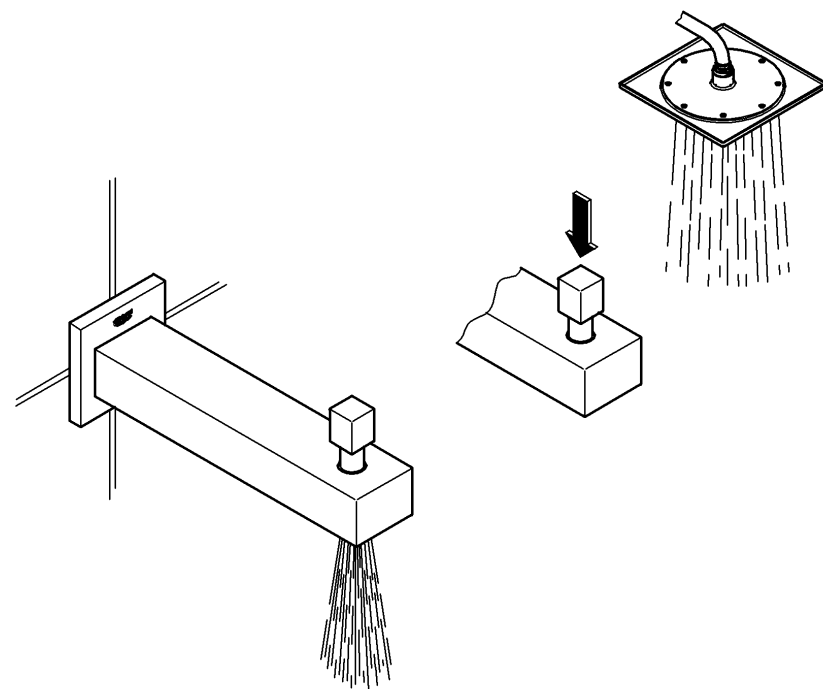

2.

