



Model # 5138

INSTRUCTIONS

1. Attach the S-Union to the tub with flat metal washer and 1/2" lock nut. Make sure that escutcheon is tight against S-Union arm (hand tighten only).

2. Attach faucet to S-Unions (3/4" rubber washers must be installed) and adjust faucet so that it sits level. Now tighten hex nuts on back of faucet to secure the S-Unions. Then tighten the 1/2" lock nuts on the back of the S-Unions to secure faucet on vertical surface.

3. Next connect the water supply lines. Must have hot going to hot side & cold to the cold side. If using 1/2" OD decorative supply line connect the hex nuts at the top of the supply lines to the back of the S-Unions. If installing inside the wall use copper fittings.

4. Once installed, remove aerator to flush faucet and water lines. This will remove any debris that may be trapped. Then attach aerator.

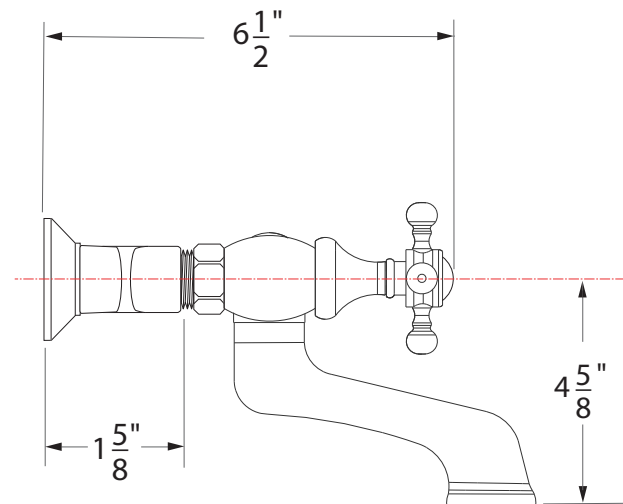
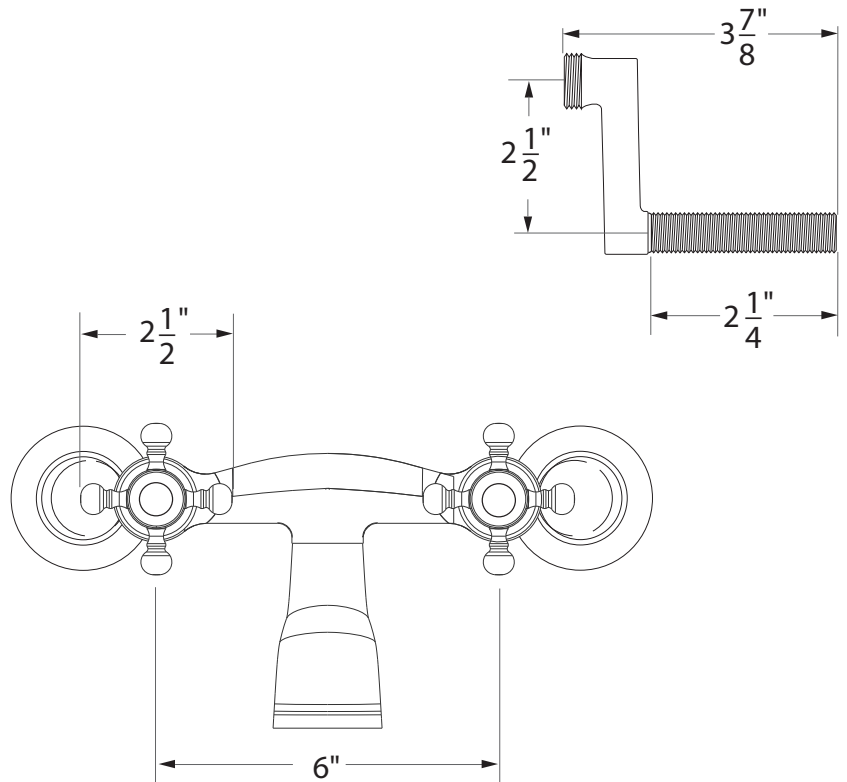

CARE AND MAINTENANCE

Minimum Maintenance is required to maintain product finish. With proper maintenance your CHEVIOT Faucet will continually look like new. Special care should be taken when cleaning your faucet and the following suggestions should help extend your faucet life.

- Cleaning should be done regularly using a soft cotton cloth and warm water, then towel dry.
- Do not use cleaners that contain abrasives or harsh chemicals; Care should be taken in selecting cleaning supplies. Many cleaners contain detergents, ammonia, or other corrosive solvents that could damage your faucet finish.
- occasionally clean with a non-abrasive wax polish.



Model # 3970 & 3970XL

INSTRUCTIONS

1. Drill two holes 1-1/8" as per your determined measurements.

2. Slide escutcheons up on bottom of each riser tube and install one 3/4" brass flange nut on each riser. Measure from bottom of valve to make sure that the nuts are threaded at same distance.

3. Lower riser tubes through floor (make sure you have valve handles facing out from each other). Install other 3/4" brass flange nuts (leave loose and attach faucet). Then tighten flange nuts, securing riser tubes to floor.

4a. If you are using plastic water lines a 3/4" FIP X barb adapter will attach directly to the 3/4" running thread on riser tube.

4b. If you are using copper pipe - you will have to use the 3/4" & 1/2" brass reducers and 3/4" fibre washers (make sure you soak the washers in water before using). Put washer between riser tube and reducer and tighten using Allen wrench. Attach to your copper line.

5. Pressure test riser tubes before closing access plate.

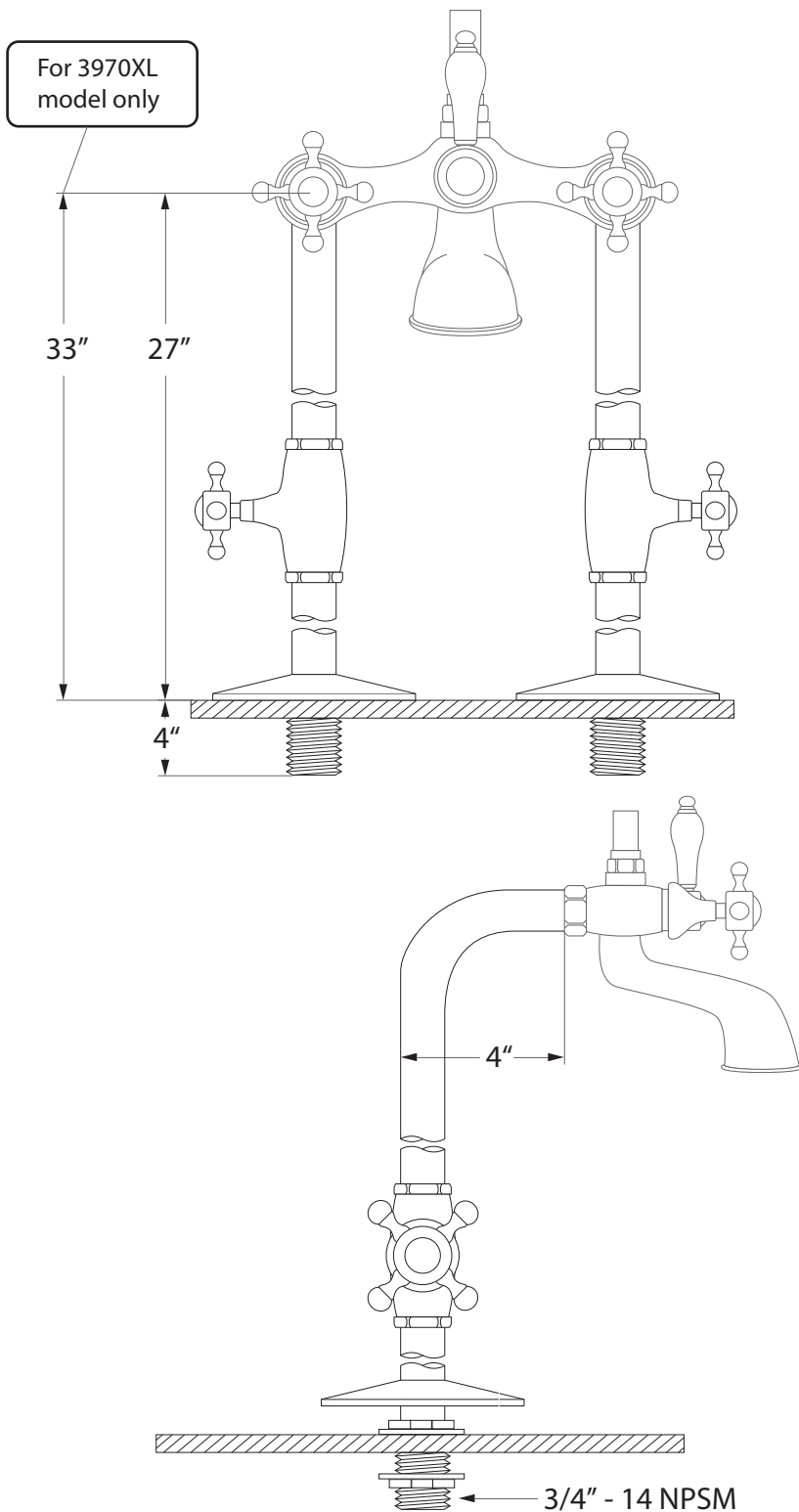

NOTE

Before drilling holes in floor, determine the width of the faucet supply nuts that you want to attach the riser tubes to (these will be for how far apart you will be drilling holes). Now determine where your tub lip will be to make sure faucet spout is at least 1" inside of tub lip.

CARE AND MAINTENANCE

Minimum Maintenance is required to maintain product finish. With proper maintenance your CHEVIOT Faucet will continually look like new. Special care should be taken when cleaning your faucet and the following suggestions should help extend your faucet life.

- Cleaning should be done regularly using a soft cotton cloth and warm water, then towel dry.
- Do not use cleaners that contain abrasives or harsh chemicals; Care should be taken in selecting cleaning supplies. Many cleaners contain detergents, ammonia, or other corrosive solvents that could damage your faucet finish.
- occasionally clean with a non-abrasive wax polish.