

TECHNICAL SPECIFICATIONS

Shower Name : *Atlantide 36 [2 pieces]*
 Collection : Shower Collection
 Dimensions : 36 X 36 X 78

Trois-Pistoles

FRONT VIEW

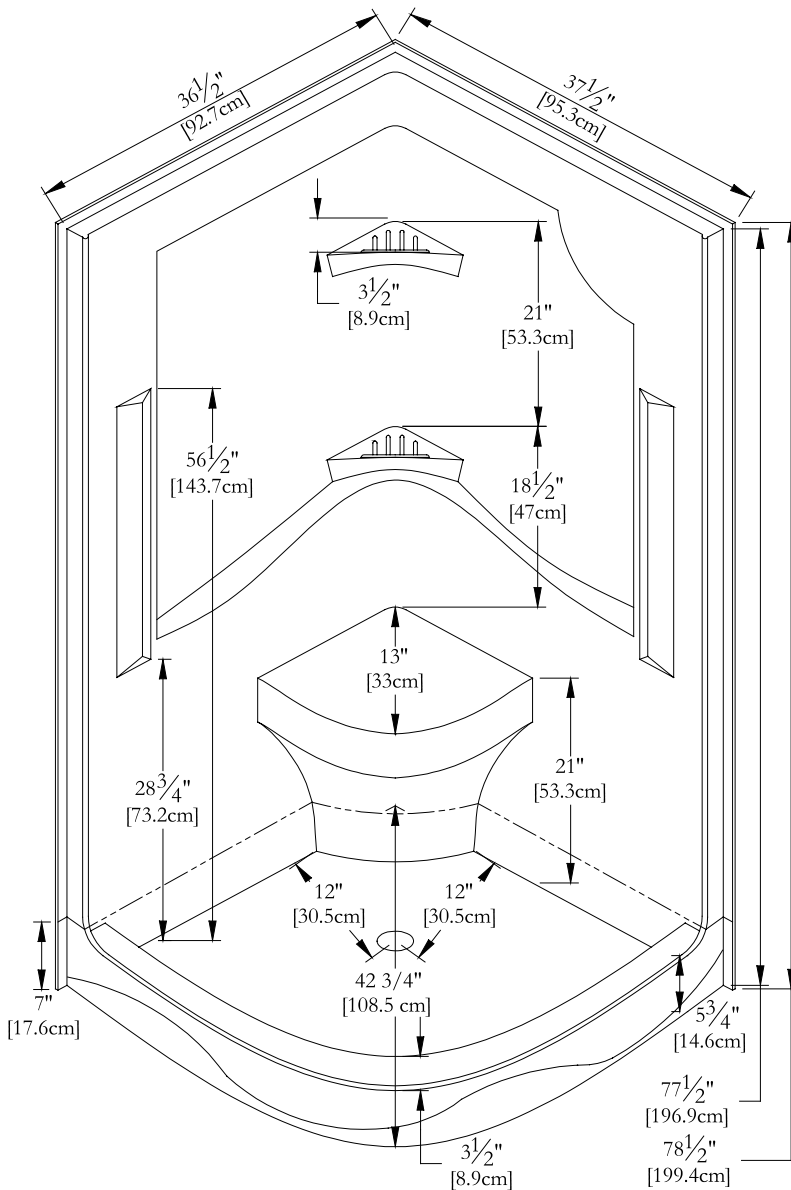

TOP VIEW

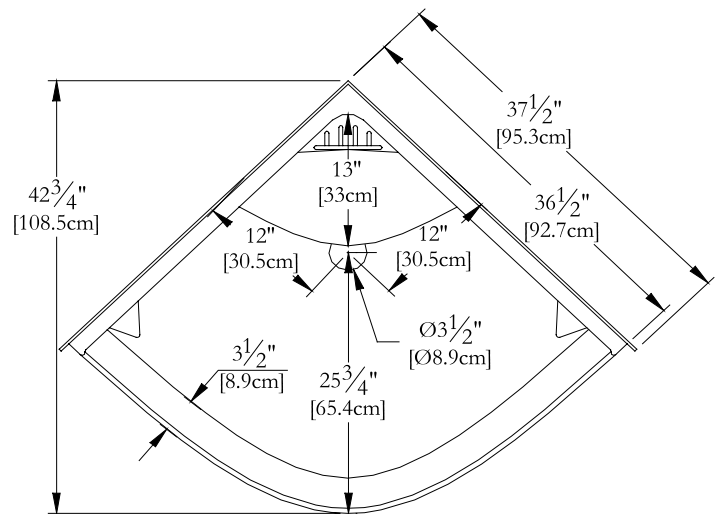

* All measurements are precise to $\pm 1/4"$ [0.63 cm]. Technical specifications are subject to change without prior notice.

HYDRO SHOWER SYSTEM

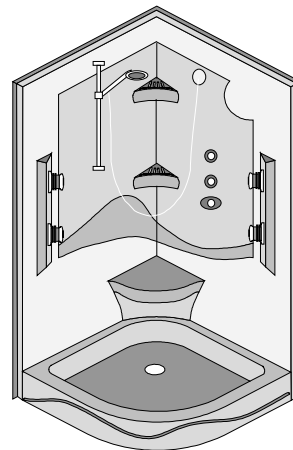

* Optional Hydro-Massage systems are factory pre-plumbed as illustrated.

* Please specify **RIGHT** or **LEFT** on order for valve installation. Right hand shown.

Océania Baths inc.

8, rue Patrice Côté
Trois-Pistoles (Québec)
Canada, G0L 4K0
MAR 2008 / REV 02

Info-Line

1-888-851-8918
1-877-332-4224

Fax

1-877-880-8918
1-866-460-4334

www.oceaniabaths.com

Home Office :

Océania Baths inc.
591, avenue des Entreprises
Thetford Mines (Québec)
Canada, G6H 4B2