

GENERAL DESCRIPTION:

Cast brass valve body. The single unit contains one handle, which sets the desired temperature. The temperature is maintained by a wax element moving a shuttle valve between hot and cold. Includes Hot Limit Safety Stop. Maximum temperature limit is 112°F. Escutcheon plate is stamped brass. Available with 1/2" or 3/4" NPT inlets and outlets. The valve has a high flow rate, ideal for multiple outlet installations.

MODEL NUMBER:

TRIM KITS:

- T010.730 Central Thermostat Trim Kit**
Less volume control. LESS Valve.

ROUGH VALVES:

- R510 Rough Valve Body only**
1/2" NPT inlets/outlets. LESS Trim.
- R530 Rough Valve Body only**
3/4" NPT inlets/outlets. LESS Trim.

NOTE:

- Requires separate on/off volume control.
- When used as a Bath/Shower:
EITHER
- a separate diverter valve (such as R420 or R430)
OR
- a diverter tub spout (requires twin ell - Model #8888.120)
IS REQUIRED

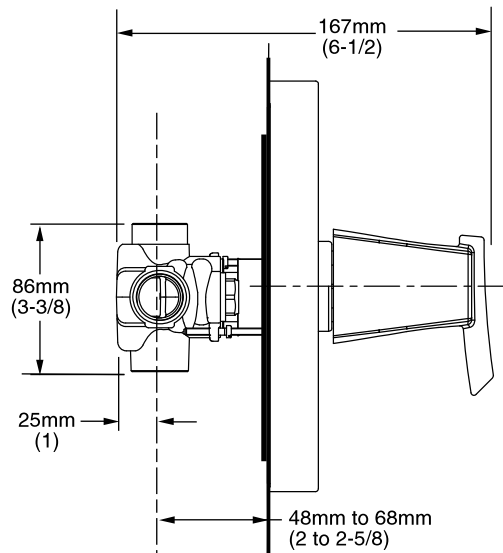

PRODUCT FEATURES:

Brass Casting: Highest quality faucet material for durability & long life.

Wax Thermostatic Unit: Permits shuttle valve to move between the hot and cold seats to maintain the pre-selected constant water temperature.

Back to Back Capable: Hot and cold can be reversed.

Spring-Loaded Check Valves: When the hot and cold water enters the fitting, both supplies pass through the spring-loaded check valves to prevent cross flow of hot and cold water.

Integrated Stop Valves: Ensure easy cleaning and servicing.

Adjustable Hot Limit Safety Stop: Limits the amount of hot water allowed to mix with cold. Reduces the risk of accidental scalding. Maximum water temperature limit may be reduced to 104 or 109 degrees Fahrenheit.

SUGGESTED SPECIFICATION:

Central Thermostat shall feature a cast brass valve body. Thermostat shall be a wax element shuttle valve. Shall also feature 1/2" or 3/4" NPT inlets and outlets. Fitting shall be American Standard Model # T010.730.____ (Trim Kit) and R510 or R530 (Rough Valve).