

SPECIFICATIONS

5 Port In-Wall Diverter Valve & Trim

1.001086

Windham Handle

(1.001086T Trim Only)

FEATURES:

This product meets and exceeds the following codes and standards:

ASME A112.18.1-2005/CSAB125.1-2005

- Replacement Cartridge: No. 18.30.112
- Two 3/4" inlets, one 3/4" outlet & two 1/2" outlets

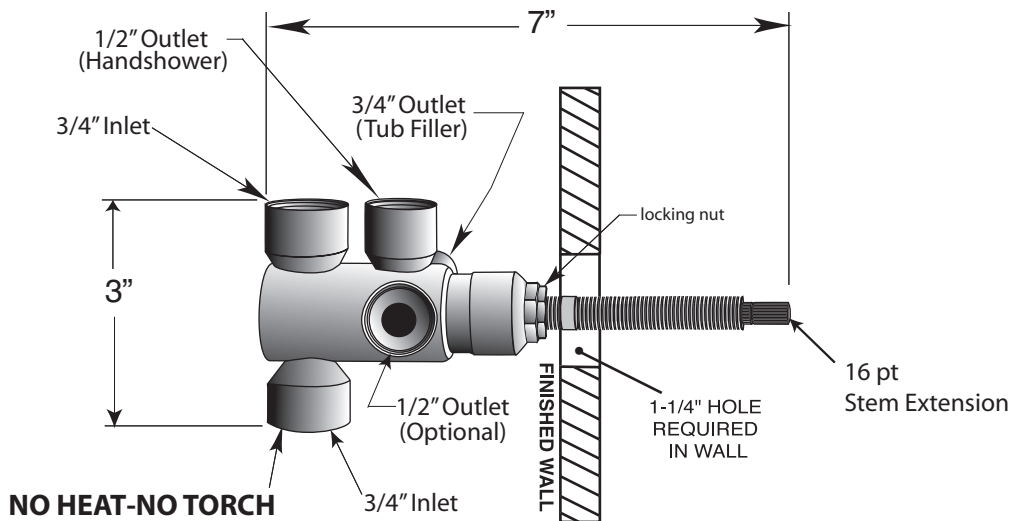
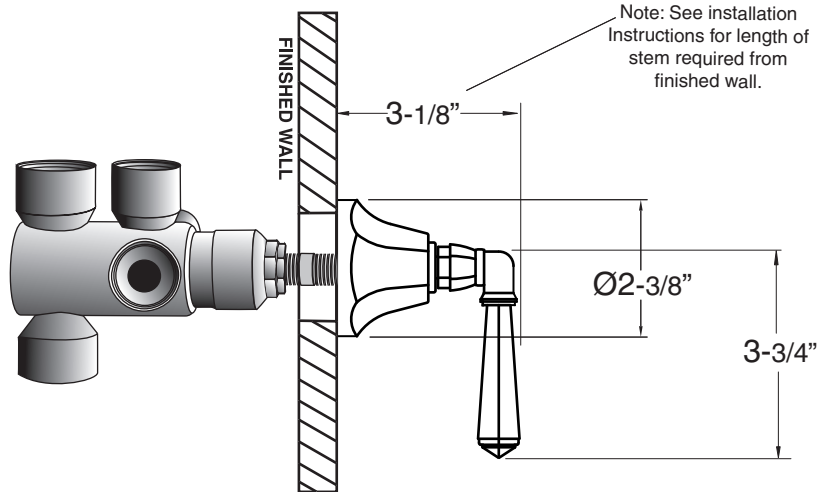

Note: Measurements are subject to change or cancellation. No responsibility is assumed for use of superseded or voided pages.