

Date:

Client:

Project:

VOLA product: RB1E



RB1E

Basin pillar tap with on-off sensor for 'hands free' operation. RB1E comes complete with batteries. Valve box for electronic mixer, VR2617 enclosed.

Flow

	Bar:	1,0	2,0	3,0	4,0	5,0
RB1E	(l/min)	5,0	5,0	5,0	5,0	5,0

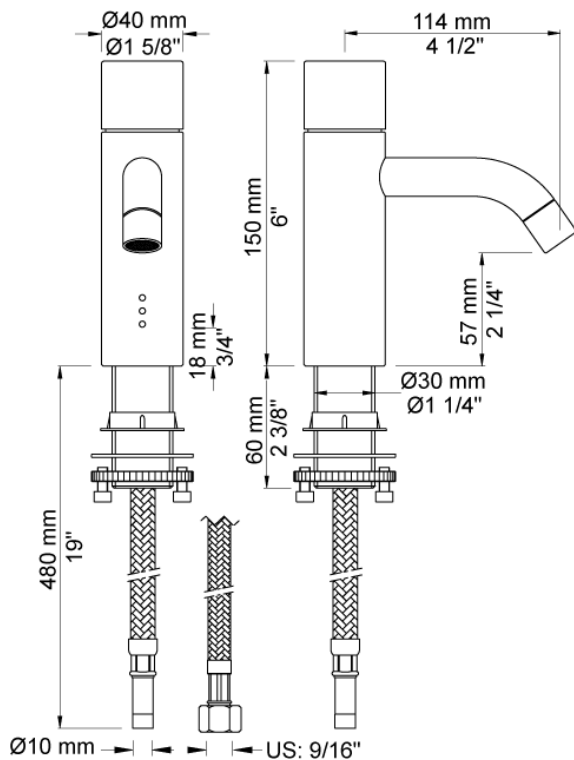

Available in colours

- Color 02, Grey
- Color 04, Light blue
- Color 05, Orange
- Color 06, Light green
- Color 08, Yellow
- Color 09, Dark grey
- Color 12, Mocca
- Color 14, Bright red
- Color 15, Dark blue
- Color 16, Polished chrome
- Color 17, Gloss black
- Color 18, White
- Color 19, Natural brass
- Color 20, Brushed chrome
- Color 21, Carmine red
- Color 25, Pink
- Color 27, Matt black
- Color 40, Brushed stainless steel



Date:

Client:

Project:

VOLA product: RB1E

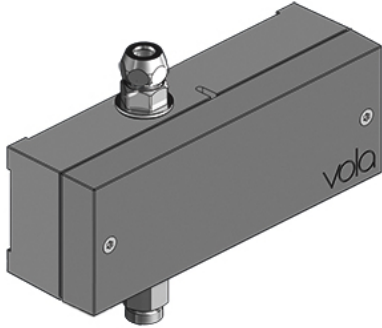

VR2617
Valve box for RB1E/4000

