

Model

CS 42™

72" x 42" x 20"

Water capacity
Maximum 74 G
Minimum 48 G

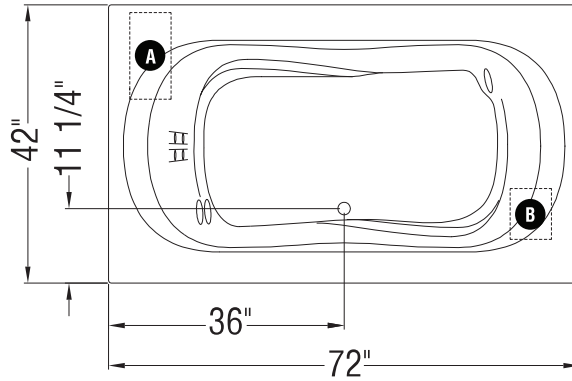

All dimensions are approximate. Structure measurements must be verified against the unit to ensure proper fit.

TRUE WHIRLPOOL
SYSTEM

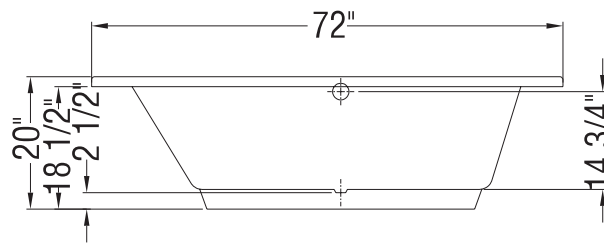
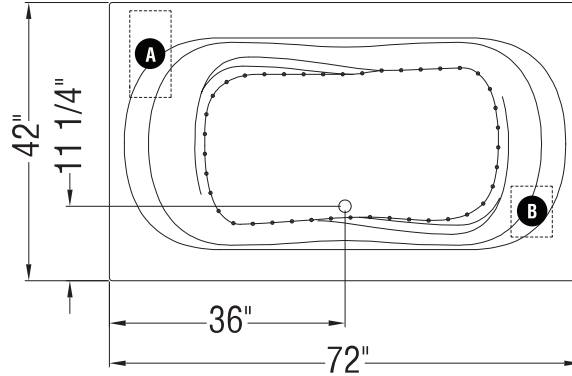

AEROEFFECT
AIR SYSTEM



- A** : Indicates pump or blower positioning
- B** : Indicates pump or blower positioning
- () : Indicates True Whirlpool jets positioning
- () : Indicates Aeroeffect airjets positioning