

*SPECIFICATIONS FOR*  
**30" CUZCO VANITY**

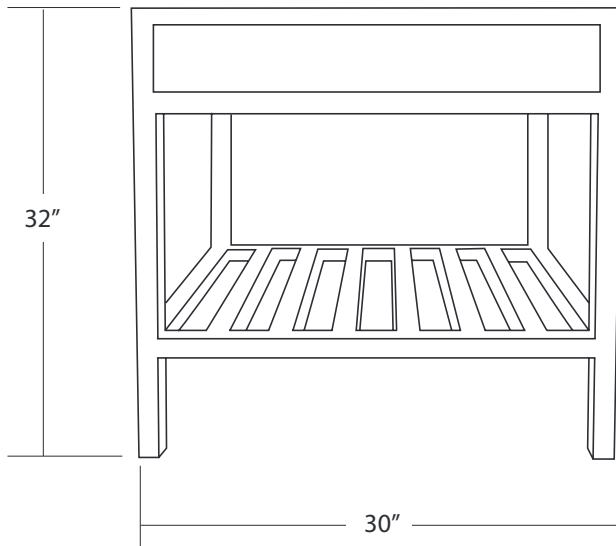

VNR302- Antique  
VNR305- Brushed Nickel

**PRODUCT DETAILS**

- \* 30" w x 21.5" d x 32" h
- \* Wrought iron
- \* Hand hammered 16 gauge recycled copper
- \* Dimensions are not exact and may vary  $\pm 1/2"$

**INSTALLATION**

- \* Freestanding vanity base

**COORDINATING PRODUCTS**

- \* Native Trails stone or Sedona vanity tops
- \* Decorative bottle trap

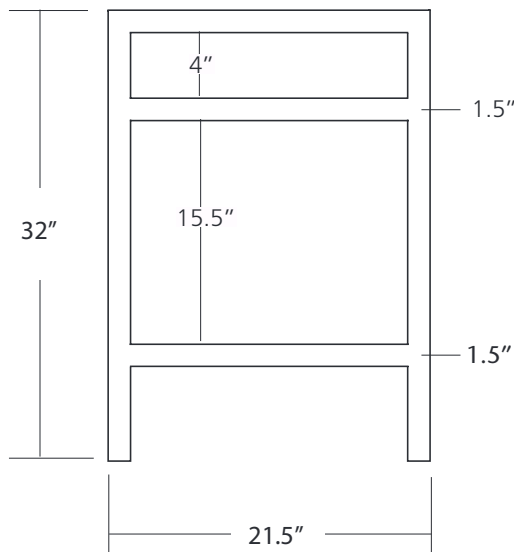

**IMPORTANT**

Due to the handcrafted nature of this product, it will vary in finish, texture, hammering, and other details. Dimensions may vary up to  $1/2"$ . We strongly recommend that you wait for the actual product before making any installation cuts.