

**FALKNER
68" COPPER DOUBLE
SLIPPER TUB**

Cat. No.
COTDSN68B-MO



L: 68"
W: 31"
H: 21 1/2" - 25"

Rim: 2 3/4"
Overflow hole: 1 1/2"
Water depth: 11 1/2" to overflow

Features:

- ▶ Constructed of 16 gauge copper (Copper is a living finish and will patina over time)
- ▶ Smooth antique copper interior and artistic mosaic exterior
- ▶ Hand polished
- ▶ No faucet holes
- ▶ With overflow
- ▶ Includes decorative base
- ▶ Drain and overflow in the center of the tub
- ▶ Hand-crafted construction makes each tub unique

Tub Finishes:

MO Mosaic

The following is recommended for COTDSN tubs without faucet holes:

- Faucet: **Part #4602, 7393 or 7410**
- Freestanding bath supplies: **Part# 4502**
- Leg tub drain: **Part# 5599**

| | |
|------------------|----------|
| Gallon Capacity: | 55 |
| Shipping Weight: | 395 lbs. |
| Empty Weight: | 170 lbs. |
| Filled Weight: | 630 lbs. |

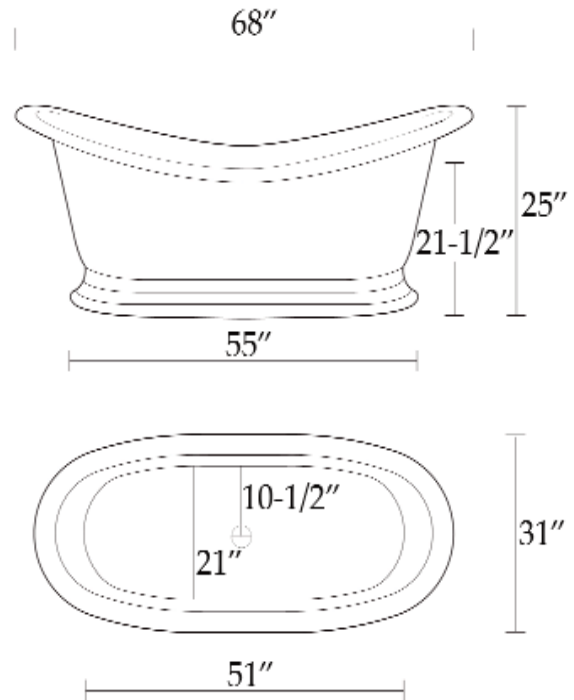

Dimensions and specifications subject to change without notice.