

Date:

Client:

Project:

VOLA product: 4011



4011

Build-in basin tap with on-off sensor for 'hands free' operation.
 4011UP = Valve 4000.
 4011AP = 160 mm spout 010, sensor VR1218K, sensor cable VR509, 2 pcs. 60 mm circular flanges 001.
 Valve box VR2617 enclosed.

Flow

	Psi:	14,5	29,0	43,5	58,0	72,5
4011	(gal/min)	1,3	1,3	1,3	1,3	1,3

Available in colours

- Color 02, Grey
- Color 04, Light blue
- Color 05, Orange
- Color 06, Light green
- Color 08, Yellow
- Color 09, Dark grey
- Color 12, Mocca
- Color 14, Bright red
- Color 15, Dark blue
- Color 16, Polished chrome
- Color 17, Gloss black
- Color 18, White
- Color 19, Natural brass
- Color 20, Brushed chrome
- Color 21, Carmine red
- Color 25, Pink
- Color 27, Matt black
- Color 40, Brushed stainless steel

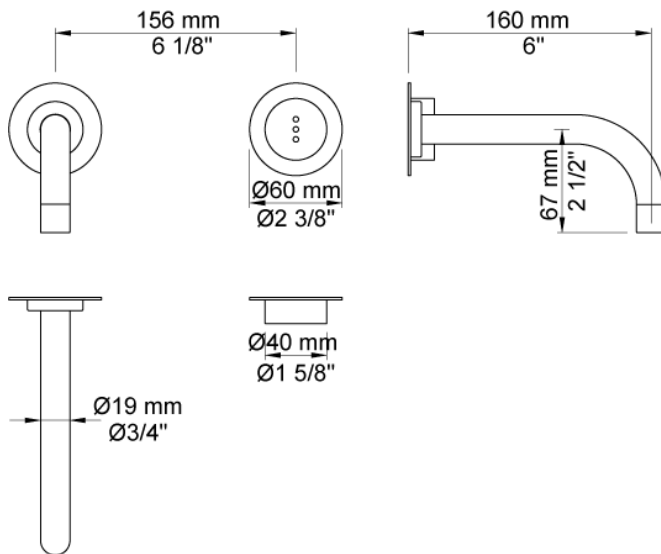

Date:

Client:

Project:

VOLA product: 4011

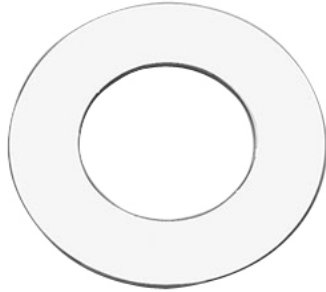

001
60 mm circular flange.
Hole Ø33 mm.



010
160 mm fixed spout with water saving aerator.

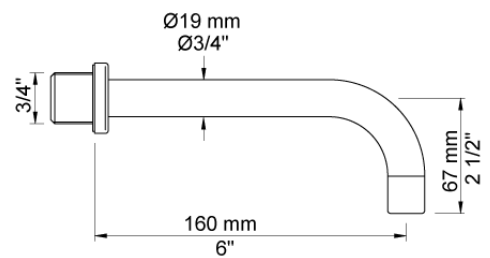

4900
Build-in basin mixer with on-off sensor for 'hands free' operation, with temperature regulation.
Valve box for electronic mixer, VR2618 enclosed.

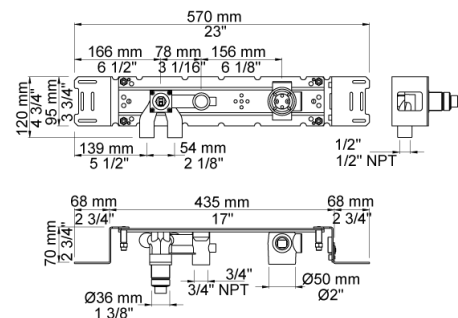

Date:

Client:

Project:

VOLA product: 4011

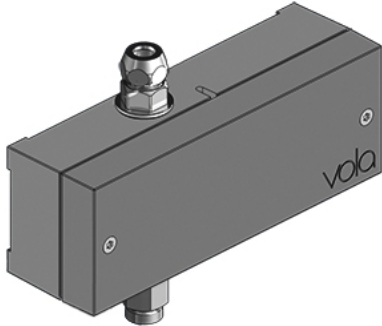

VR2617
Valve box for electronic RB1E/4000/4300/4800

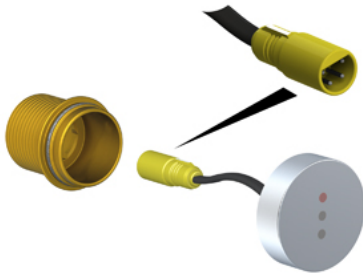
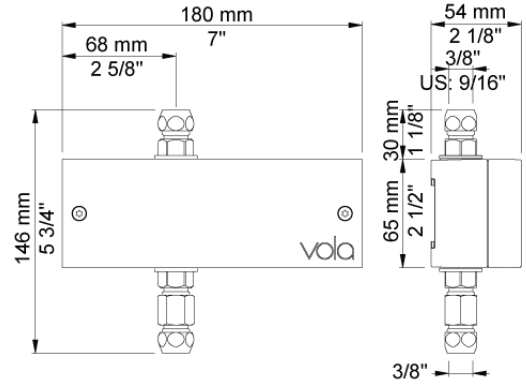

VR1218K
Sensor for electronic mixer 4000 and 4100. As of 06-2014.

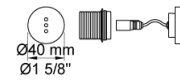

VR509

