

**Centerset:** Cast & tubular brass, no swivel.

**Trim:** Hot forged brass.  
Three handles available

**Valve:** 1/2" Ceramic disc valve cartridge.  
1,000,000 Tested cycles.  
1/4 Turn positive on/off.  
Non-rising spindle.

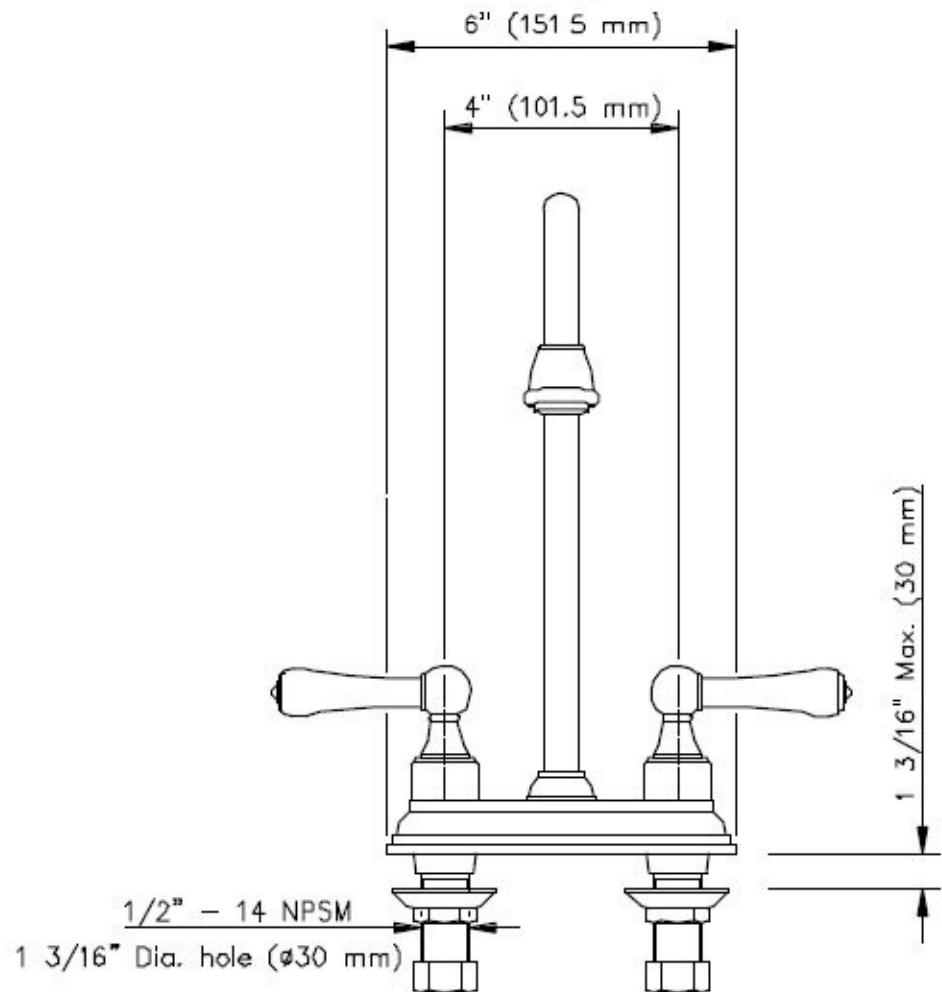

**Inlets:** Sized for either coupling or sweat connections

**Pressure:** Maximum (tested): 200 psi (14.1 kg/cm).  
Recommended (flowing): 15-75 psi (1.1-5.3 kg/cm)

**Waste:** 1 1/4" Pop-up waste.

**Flow rates:** 2.2 GPM @ 60psi (flowing); (8.4 l/min. @ 4.2 kg/cm (flowing))