

Features:

- Forged brass construction
- Ceramic disk valve cartridge 18.30.865
- Adjustable hot limit safety stop
- Reversible cartridge
- 5.6 GPM @ 45 PSI
- Meets: ASME A112.18.1-2005/CSAB125.1-2005

**SPECIFICATIONS**  
**Series 300**

Pressure Balance Tub & Shower  
1.300968  
Salem Handle  
(1.300968T Trim Only)

Cutaway View

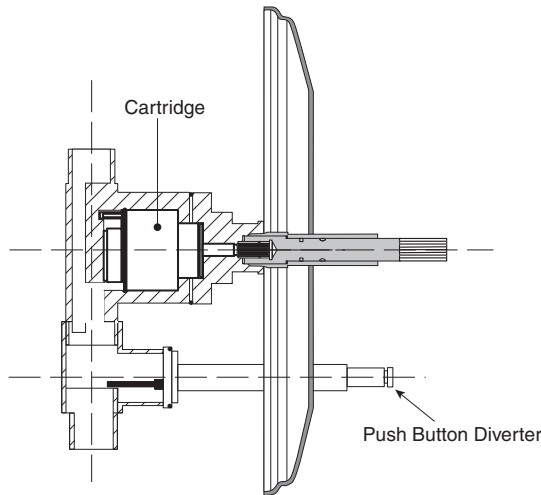

Top View

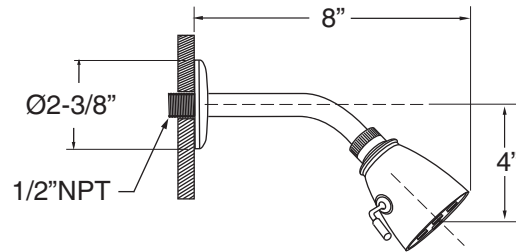
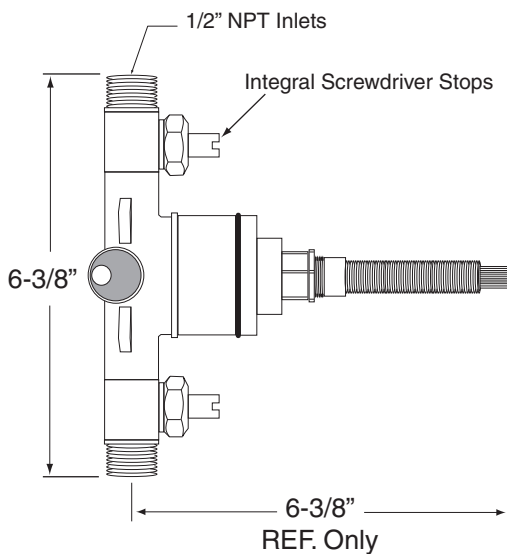

Note: See installation instructions for length of stem required from finished wall.

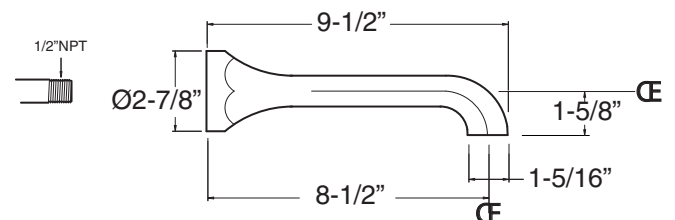
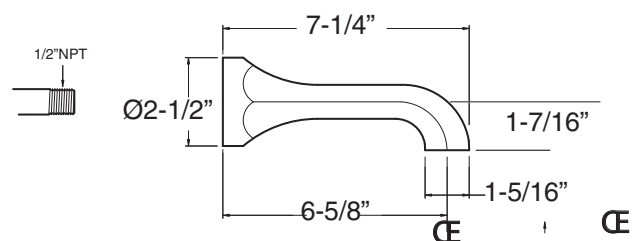
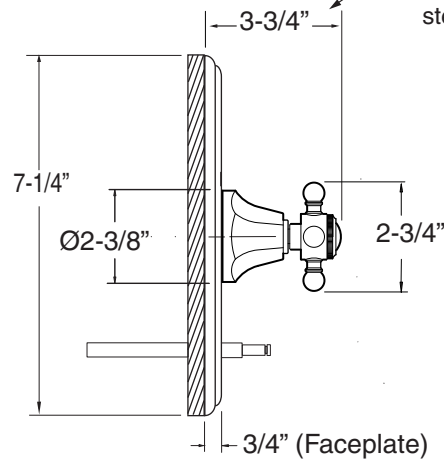

Note: Measurements are subject to change or cancellation. No responsibility is assumed for use of superseded or voided pages.

# Series 300

## Salem Pressure Balance Tub & Shower Set

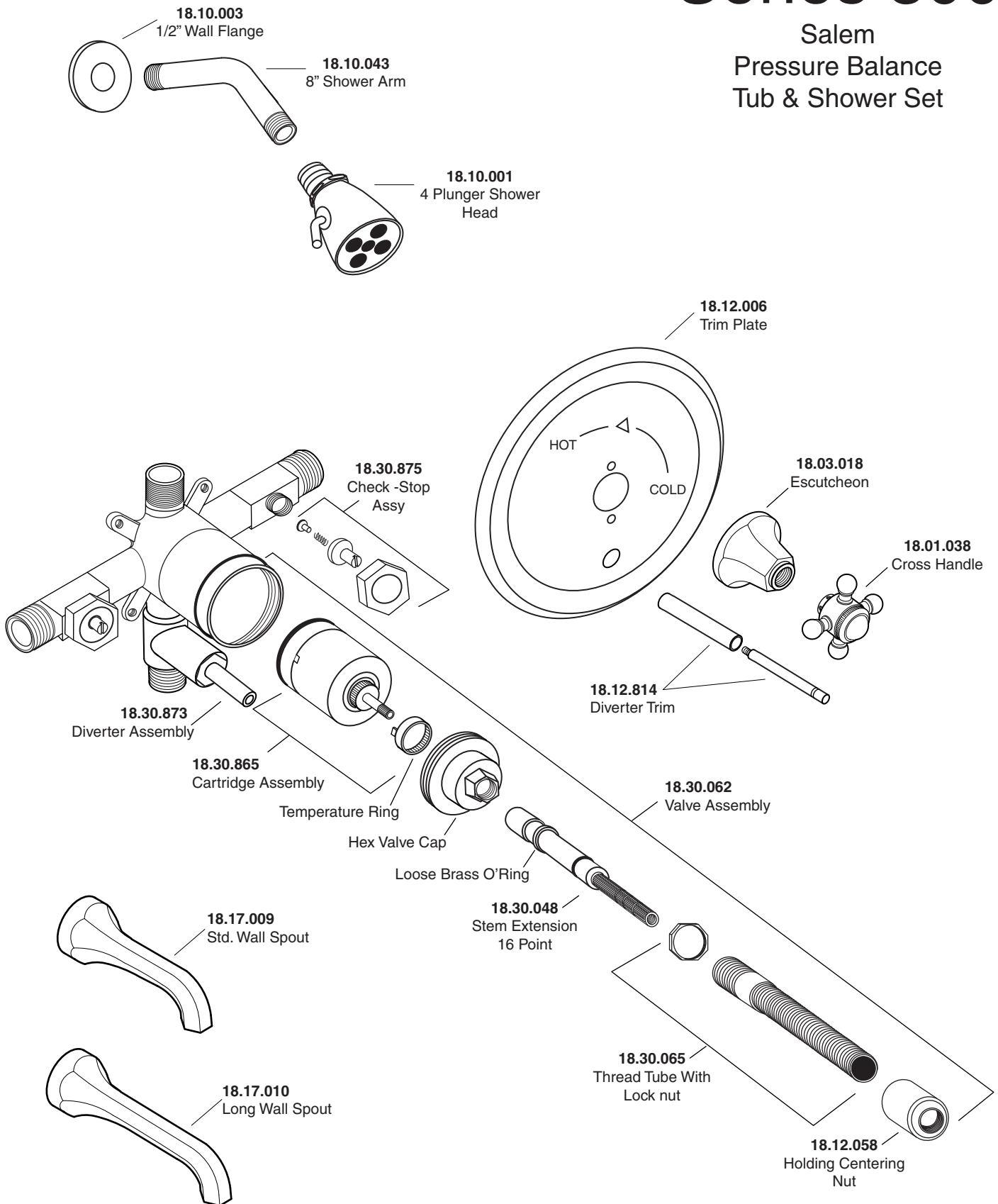

American Faucet & Coatings Corporation.

Tel: 760-598-5895, Toll Free Fax 800-621-8383, customerservice@sigmafaucet.com