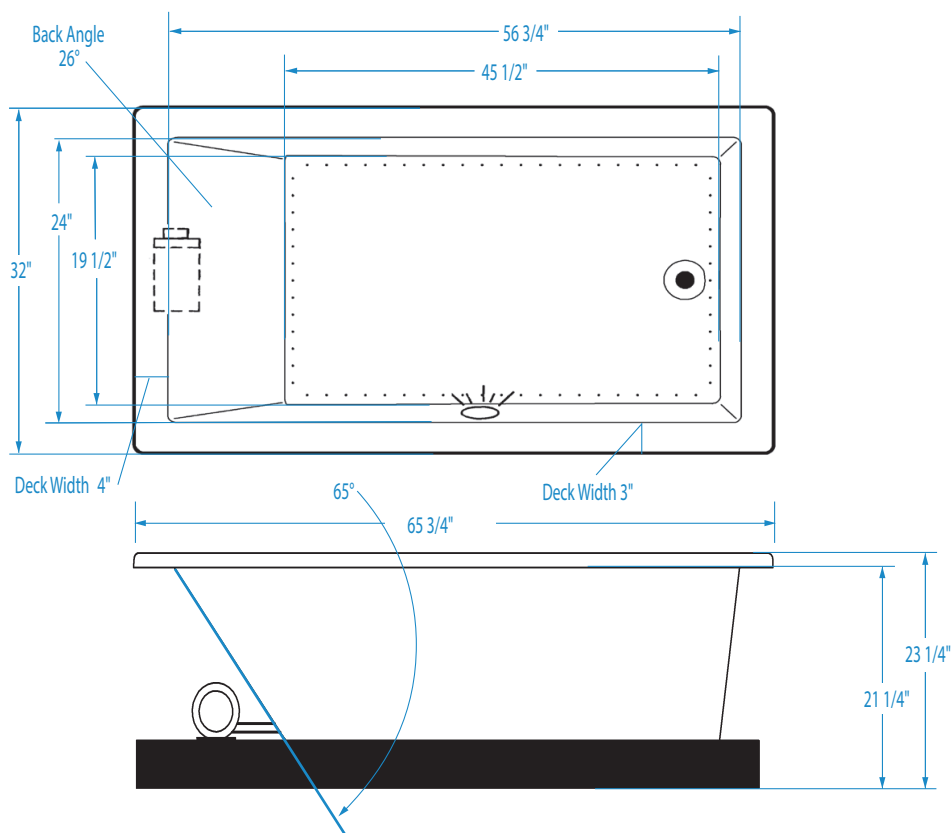

SERENITY 34

 65 3/4 x 32 x 23 1/4 (1670 x 810 x 590)
 inches (mm)

FEATURES lbs (kg) Dimensional Tolerance ± 3/8". Dimensions needed for site preparation should be measured from the unit. Aquatic assumes no responsibility for preparatory work.

Type and Model #	Material	System	Powered By	Heater	Controls	Drain	Pkg. Wt.
Soaker #AI34AIR6632TO	Acrylic	–	–	–	–	Universal	156 (71)
HotSoak #AI34AIR6632HS	Acrylic	Water circulation	Pump	1.5 kW Inline maintenance	Electronic	Universal	186 (84)
Air Bath #AI34AIR6632	Acrylic	Air channel	Variable speed blower	Integrated	Electronic	Universal	186 (84)
DriftBath #AI34AIR6632DB	Acrylic	Water circulation	Pump	Integrated	Electronic	Universal	197 (89)

DIMENSIONS inches (mm)

Width Overall / Net	Depth Overall / Net	Height Overall / Net	Skirt Height
65 3/4 (1670)	32 (810)	23 1/4 (590)	–

SUMP DATA inches (mm)

Capacity to Overflow gal (ltr)	Min. Operating Capacity gal (ltr)	WIDTH @ centerline		DEPTH @ centerline	
		Top	Bottom	Top	Bottom
79 (299)	–	56 3/4 (1440)	45 1/2 (1155)	24 (610)	19 1/2 (495)

PLUMBING DIMENSIONS inches (mm)

A	B	Drain Diameter / Clearance
2 3/4 (70)	10 3/4 (275)	

ELECTRICAL DATA

Component	Specification	Requirement
Heated Blower (Air Bath)	10.5 AMP; 120V	15 AMP; 120V, separate circuit; Class A GFCI
Pump (HotSoak)	1/15 HP; 1.3 AMP; 120V	20 AMP; 120V, separate circuit; Class A GFCI
Heater (HotSoak)	1.5 kW; 12 AMP; 120V	
Pump (DriftBath)	3/4 HP; 8.8 AMP; 120V	15 AMP; 120V, separate circuit; Class A GFCI

NOTES:

1) Where applicable, utilize cut-out templates packed with unit for deck cutouts.

2) 16 x 16 (405 x 405) minimum access required at pump/blower location(s).

3) For Low Profile Deck, framing height will need to be increased by an additional 1".

Each Serenity air bath is equipped with an air heating system to raise the temperature of the air entering the bath. This air temperature will be lower than the bathing temperature of the water, but will help reduce rapid decrease in water temperature. In addition, the air coming from the air jets will feel cool against the skin. This system does not heat the water.