



## PS-111

### FEATURES:

- \* Sink Size: 21" x 14 3/4" x 6"
- \* Material: Vitreous China
- \* Counter Top Recessed Sink
- \* Recommended Drain: DS-001
- \* For Faucets With Overflow
- \* For Use With Standard Pop Up Drain
- \* Warranty: One Year Limited Warranty

### CODES / STANDARDS APPLICABLE

- \* CSA B45
- \* ASME A112.19.2

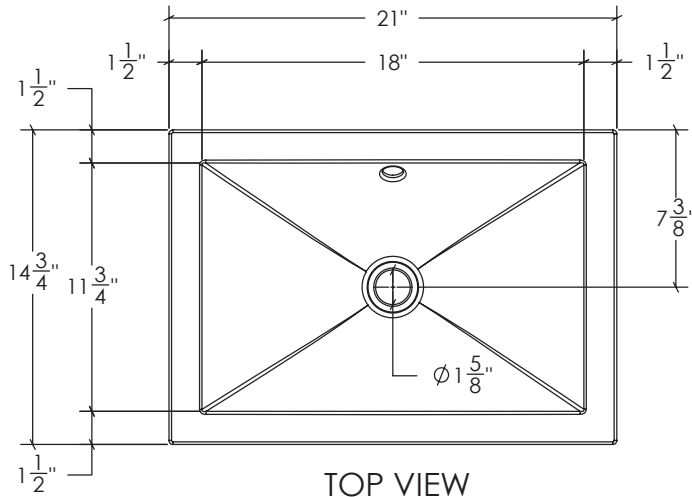

TOP VIEW

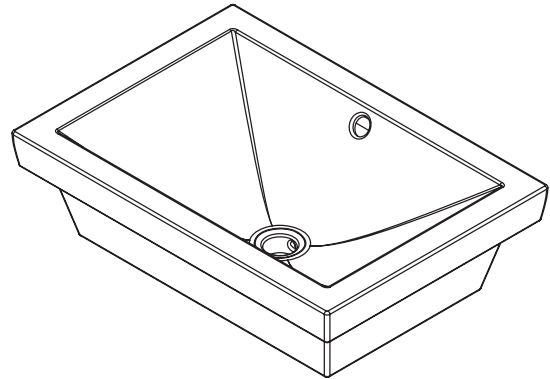

3D VIEW

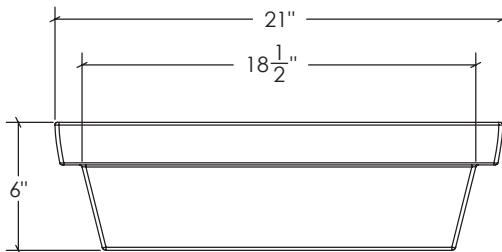

FRONT VIEW

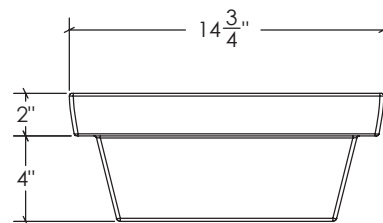

SIDE VIEW

## JOB INFORMATION:

Job Name \_\_\_\_\_

Date Specified \_\_\_\_\_

Contractor \_\_\_\_\_

\* Specifications and drawings provided on this sheet are for illustration only. Cantrio Concepts will not be held responsible for cutouts made without the actual product or product template.