

4

3

2

1

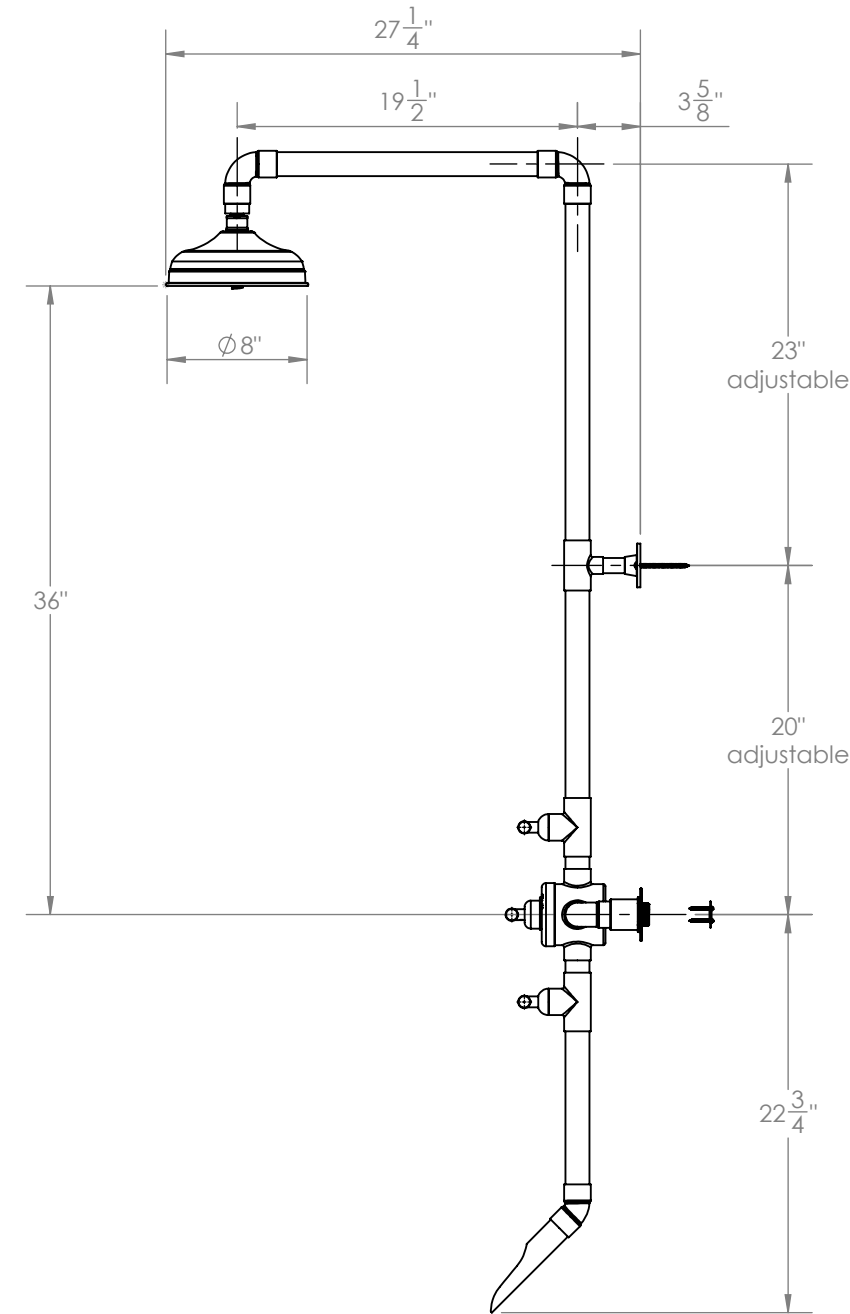
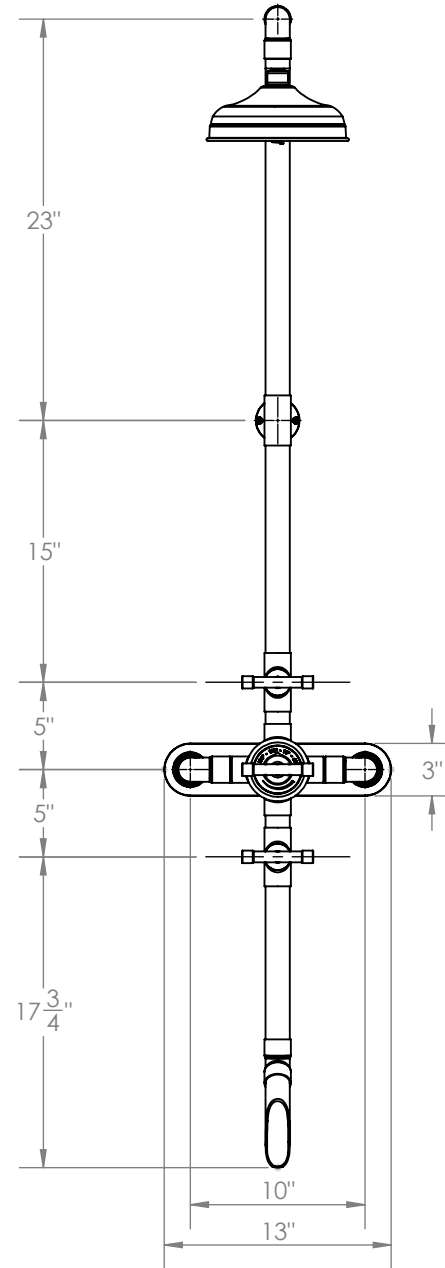
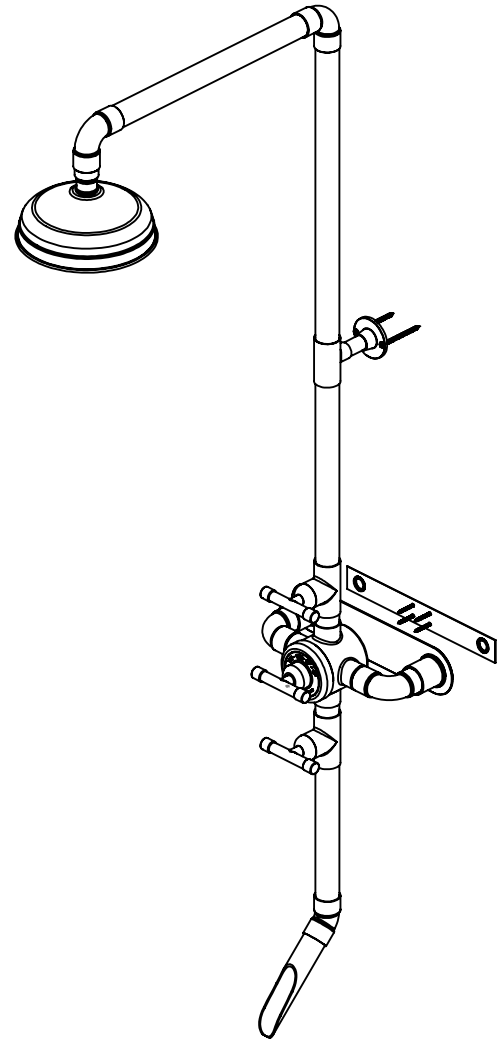

**PROPRIETARY AND CONFIDENTIAL**  
 THE INFORMATION CONTAINED IN THIS DRAWING IS THE SOLE PROPERTY OF Sonoma Forge. ANY REPRODUCTION IN PART OR AS A WHOLE WITHOUT THE WRITTEN PERMISSION OF Sonoma Forge IS PROHIBITED.

		UNLESS OTHERWISE SPECIFIED:		NAME	DATE	Sonoma Forge	
		DIMENSIONS ARE IN INCHES TOLERANCES: .005" FRACTIONAL ± ANGULAR: MACH ± BEND ± TWO PLACE DECIMAL ±.01 THREE PLACE DECIMAL ±.005		DRAWN	TAD	11/10/2021	TITLE:
		INTERPRET GEOMETRIC TOLERANCING PER:		CHECKED			Waterbridge 670 Wall Mounted Thermostatic Shower
		MATERIAL		ENG APPR.			
		FINISH		MFG APPR.			SIZE
NEXT ASSY	USED ON			Q.A.			DWG. NO.
APPLICATION		DO NOT SCALE DRAWING		COMMENTS:			WB-SHW-670
							REV
							SCALE: 1:11 WEIGHT:
							SHEET 1 OF 1

4

3

2

1

B

B

A

A