

MODERN INDUSTRIAL 12" HEAVY DUTY DRAWER PULL

HMP-1200

• FITS MATERIALS FROM 1/4" TO 1-1/2" THICK

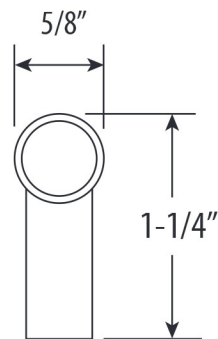
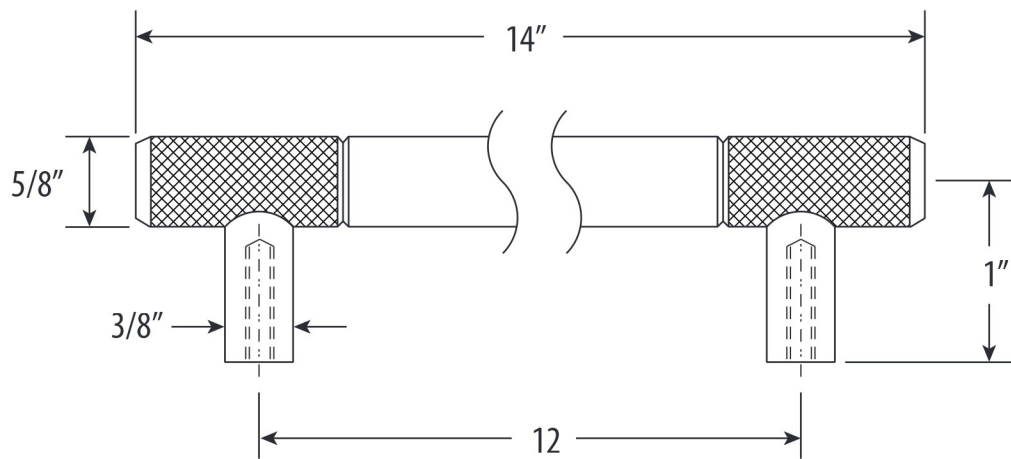

END VIEW



DIMENSIONS MAY VARY AND ARE SUBJECT TO CHANGE. NO RESPONSIBILITY IS ASSUMED FOR USE OF SUPERCEDED OR VOIDED DATA