



California Faucets®

# StyleTherm®

## TO-TH1L/THC1L/THF1L/THO1L-XX

### 1/2" Thermostatic Valve with Single Volume Control Trim Installation Instructions

CALIFORNIA FAUCETS RECOMMENDS THAT ALL PLUMBING PRODUCTS BE INSTALLED BY A LICENSED PROFESSIONAL

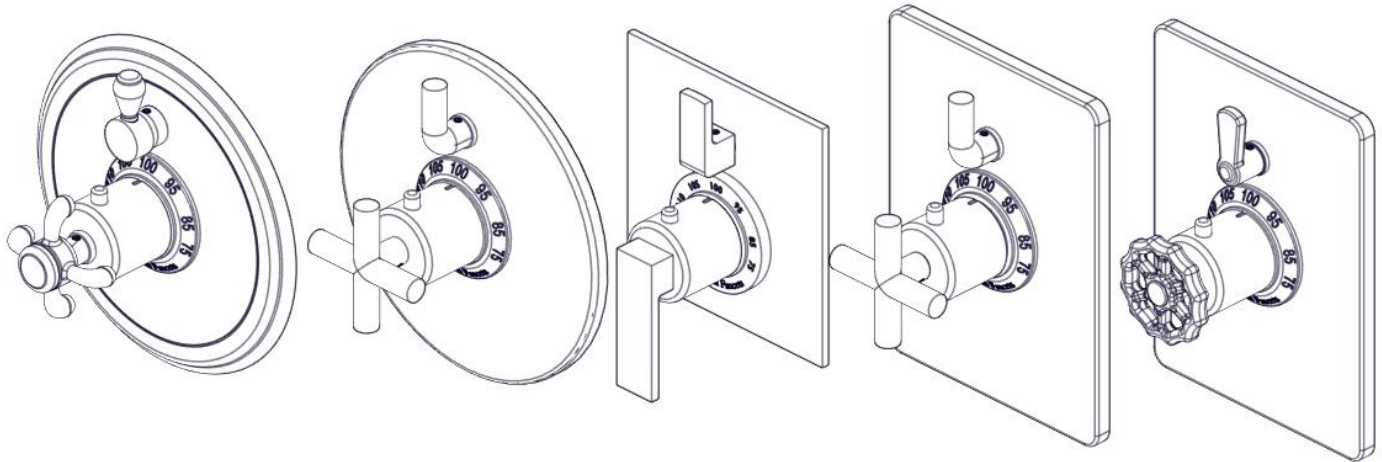

#### IMPORTANT: Instructions to the Installer

Please read these instructions, fill in blanks below, and then give these instructions to the end user.

#### WARNING: Risk of Scalding

This valve **MUST** have the TEMPERATURE SETTING verified during installations. The **INSTALLER** is responsible for installing the valve and setting of water temperature in accordance with these instructions.

THIS THERMOSTATIC VALVE HAS BEEN PRESET

BY \_\_\_\_\_

OF \_\_\_\_\_

TO A MAXIMUM DISCHARGE TEMPERATURE OF \_\_\_\_\_ °F.

ANY CHANGES TO THIS SETTING MAY INCREASE THE DISCHARGE TEMPERATURE AND COULD RISK SCALDING OF END USER.

DATE \_\_\_\_\_

**CAUTION: Danger of scald injury.** Valve can be recalibrated to provide higher temperature water. This valve has been preset at the factory to provide a range of water temperatures. Any change in settings or water inlet conditions from those used during calibration at the factory may raise the outlet temperature and may cause scalding. The responsibility for the proper installation and any recalibration of this valve lies with the installer.

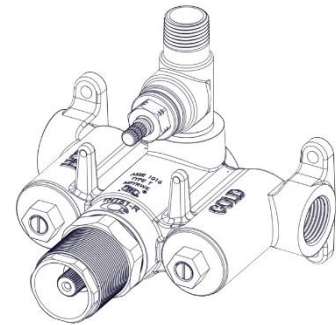

TH51-R  
(ROUGH)

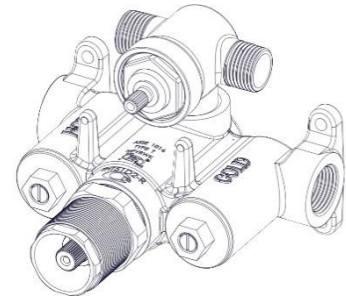

TH51D2-R  
(ROUGH)

## TEMPERATURE SETTING

- Remove SCREW (2), WASHER (3), and MUDGUARD (4) from installed VALVE (1)
- Push plastic TEMPERATURE LIMIT STOP (6) onto THERMOSTATIC CARTRIDGE (7) as shown
- Temporarily place BONNET (8) onto THERMOSTATIC CARTRIDGE STEM (7a)
- Place STEM (19) onto STOP/VOLUME CONTROL (19a) and using PHILLIPS SCREWDRIVER (19c) secure STEM (19) with SCREW (19b)
- With both hot and cold water supplies on, open STOP/VOLUME CONTROL (19) valve to one output device
- Use temperature measuring device to confirm temperature is 100°F [38°C] when BONNET (8) button is positioned straight up at 12 o'clock
- When button on BONNET (8) is depressed and rotated full left (CCW), the maximum temperature discharged from valve will be 115°F [46°C] (**Note:** Follow all applicable local plumbing codes when setting maximum discharge water temperature)
- Carefully remove BONNET (8) and place aside until trim is installed

**NOTE:** If temperature is not 100°F [38°C] with BONNET (8), button at 12 o'clock, the CARTRIDGE STEM (7a) must be rotated to change temperature setting (clockwise (CW) for cooler & counter-clockwise (CCW) for warmer)

**WARNING:** Forcibly rotating thermostatic cartridge stem prior to installing handle trim, will damage cartridge and void warranty

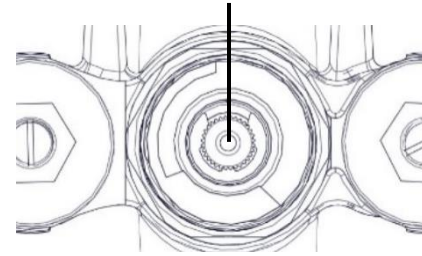
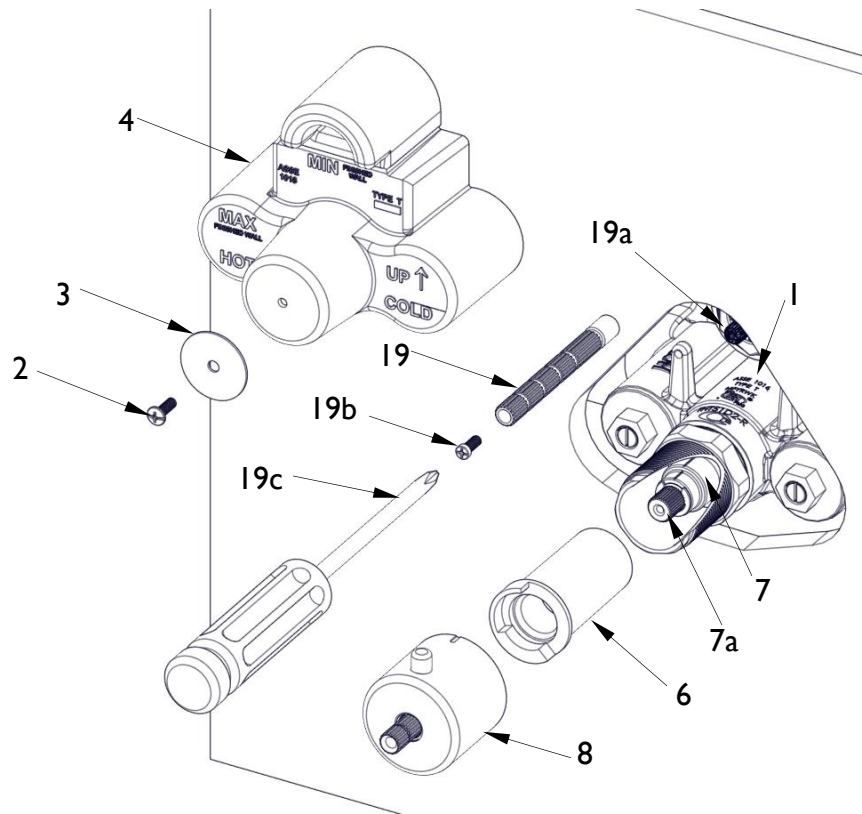

Front view of TEMPERATURE LIMIT STOP

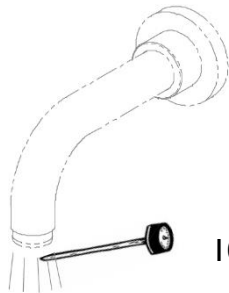

100°F [38°C]

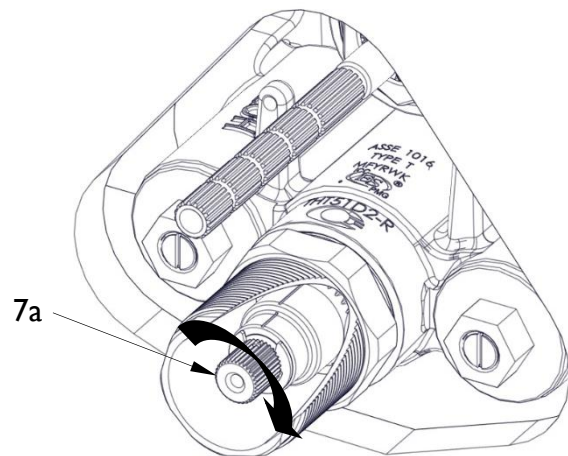

Rotate CW for Cooler (shown)  
Rotate CCW for Warmer

# 2

## INSTALL TRIM

**WARNING:** If distance between finish wall & end of ALL THREAD (10a) is less than 1-5/16" [33mm], an extension kit (not included) **MUST** be used; **DO NOT** loosen PACKING NUT (10) to extend length as this will cause valve to not operate properly & lead to possible flood

- Position FACEPLATE (9) onto ALL THREAD (10a) as shown
- Install SLEEVE (11) onto ALL THREAD (10a) and tighten to secure FACEPLATE (9) against shower wall
- Place BONNET (8) onto THERMOSTATIC CARTRIDGE STEM (7a)
- Secure BONNET (8) with SCREW (12)
- Place HANDLE (13) onto BONNET (8) and tighten handle SETSCREW (14)
- Cut VOLUME CONTROL STEM (19), 1/2" [13mm] from surface of FACEPLATE (9)
- Place VOLUME CONTROL HANDLE (13a) onto VOLUME CONTROL STEM (19) and tighten SETSCREW (14)

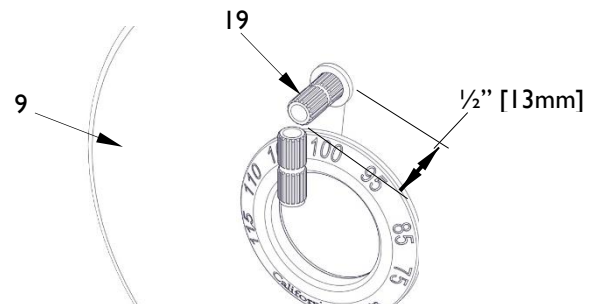
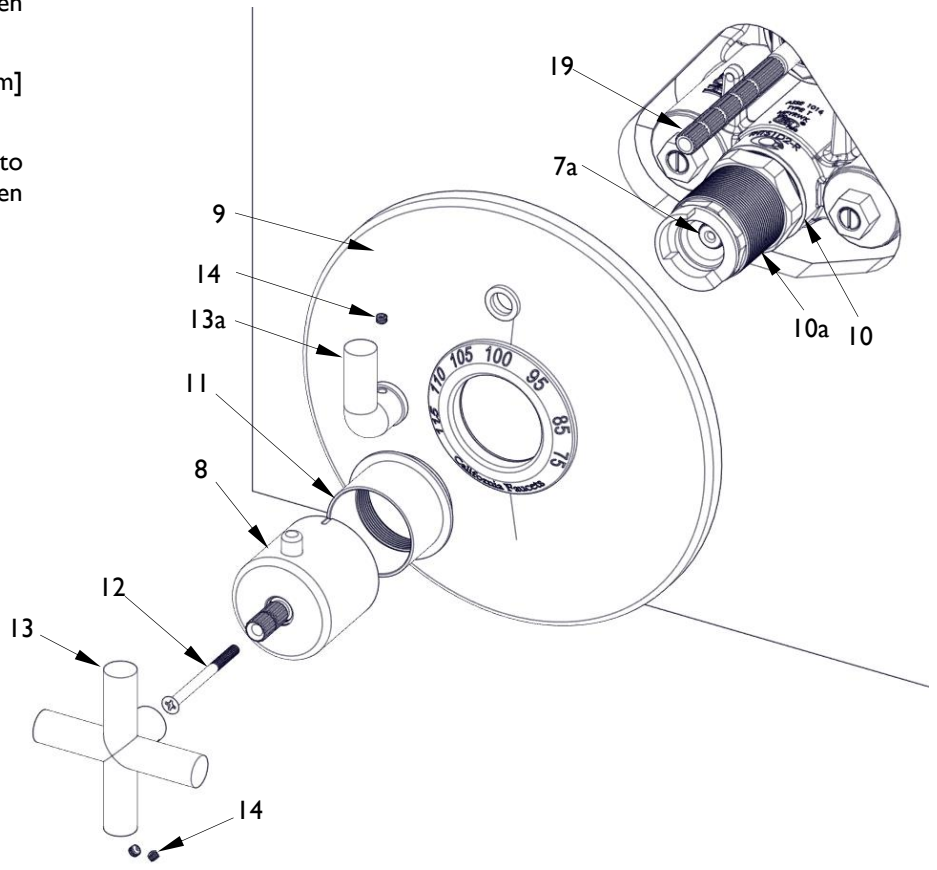
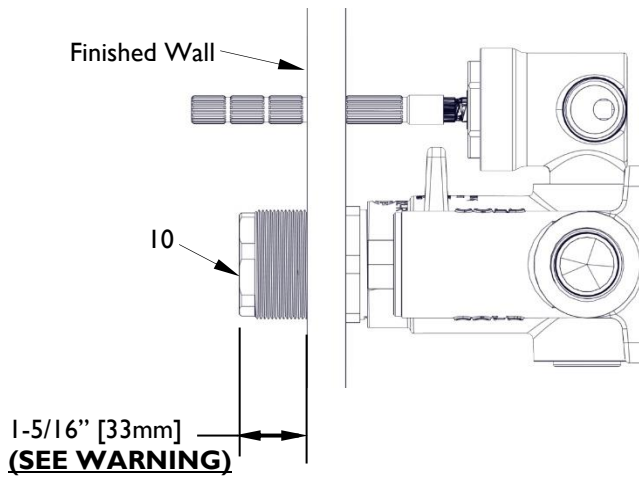

### 3 MAINTENANCE

The thermostatic cartridge has built-in screens to prevent debris from affecting proper operation of anti-scald protection. Debris may build up on screens this will affect water flow and will require occasional service.

#### Thermostatic Cartridge Service

- Loosen all SETSCREWS (14), then remove HANDLE (13), VOLUME CONTROL HANDLE (13a), SCREW (12), BONNET (8), SLEEVE (11) and FACEPLATE (9)
- Shut off water supply to thermostatic cartridge by turning hot & cold SERVICE STOP SCREW (15) clockwise (inward) until screw stops
- Remove plastic TEMPERATURE LIMIT STOP (6) from THERMOSTATIC CARTRIDGE (7)
- Remove PACKING NUT (10) using WRENCH (10b) SPD-880618-91 (sold separately) from the BODY (1)
- Gently pull THERMOSTATIC CARTRIDGE (7) out of BODY (1) (rotating cartridge while pulling may assist in removal)
- Rinse cartridge screens under running water to remove any possible debris
- Prior to installing THERMOSTATIC CARTRIDGE (7) into BODY (1), apply a thin film of non-petroleum based grease onto O-RING (16)
- Align THERMOSTATIC CARTRIDGE STEM (7a) indentation or ink line with THERMOSTATIC CARTRIDGE GROOVE (7b) and insert THERMOSTATIC CARTRIDGE (7) into BODY (1) with THERMOSTATIC CARTRIDGE GROOVE (7b) straight up at 12 o'clock position
- Tighten PACKING NUT (10) to factory torque setting of 10 ft-lb (13.6 Nm) using WRENCH (10b) SPD-880618-91 (sold separately)
- Open water supply to thermostatic cartridge by turning hot & cold SERVICE STOP SCREW (15) counter-clockwise (outward) until screw stops
- See **1 TEMPERATURE SETTING**
- See **2 INSTALL TRIM**

#### Check Valve Service

- Shut off water supply to valve inlets at main or valve upstream from BODY (1)
- Remove CHECK VALVE (17) from BODY (1)
- Rinse CHECK VALVE (17) under running water
- Prior to installing CHECK VALVE (17) into BODY (1), apply a thin film of non-petroleum based grease onto O-RING (18)
- Tighten CHECK VALVE (17) to 10 ft-lb [13.6 Nm]
- See **1 TEMPERATURE SETTING**
- See **2 INSTALL TRIM**

