

## Widespread Lavatory Faucet Installation Instructions

**CALIFORNIA FAUCETS RECOMMENDS THAT ALL PLUMBING PRODUCTS BE INSTALLED BY A LICENSED PROFESSIONAL**

**IMPORTANT: Read all instructions prior to installation and provide copy of instructions to consumer.**

### Operating Specifications:

Recommended Supply Pressure: 20 to 70 psi\*†

Maximum Flow Rate: 1.2 gpm

\* Operating pressures between hot and cold supplies should vary no more than 30 psi.

† If water pressure exceeds 70 psi, install a Pressure-Reducing Valve (PRV).

## I INSTALLING SPOUT

- Insert spout SHANK (1a) through center hole in sink

**NOTE:** Sink / Deck recommended hole size is  $\text{Ø}1\text{-}3/8\text{'}$

- Place SS WASHER (2) and FLANGE NUT (3) onto spout SHANK (1a) from below
- Align SPOUT (1) and secure with FLANGE NUT (3)
- With O-RING (4) in place at end of spout SHANK (1a), slide 4-WAY TEE (5) onto spout SHANK (1)
- Place RUBBER WASHER (6), BRASS WASHER (7) and NUT (8) onto spout NIPPLE (1b) and tighten

**IMPORTANT:** TEE (5) should be tightened to create watertight seal and positioned to allow ease of attachment of valve hoses

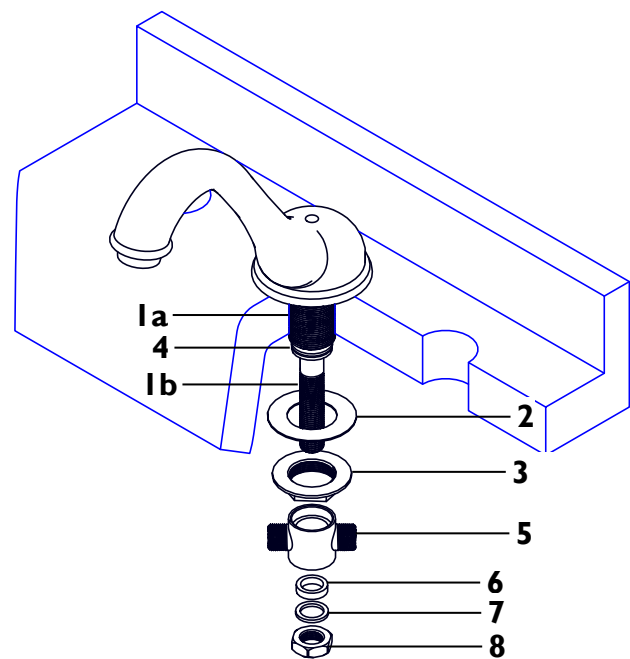
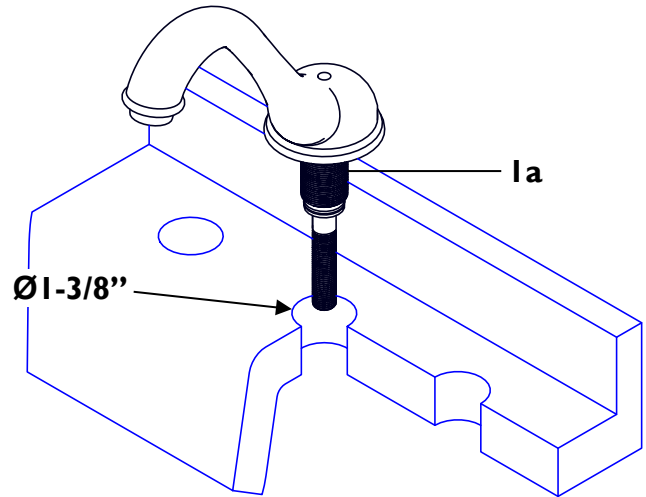

## 2

### INSTALLING VALVE

- From underneath, insert VALVE (9) through appropriate sink/deck hole

**IMPORTANT:** VALVES (9) are labeled as follows:

**BLUE** is **COLD** left turning (counter-clockwise) closed

**RED** is **HOT** right-turning (clockwise) closed

- Position flange NUT (10) and WASHER (11a) so that VALVE (9) extends above sink/deck surface according to table below
- Secure VALVE (9) with TOP NUT (12) and WASHER (11b) noting correct TOP NUT (12) orientation

**IMPORTANT:** TOP NUT (12) **MUST** have flat side towards deck

- Attach RING (13) onto ESCUTCHEON (14)
- Place ESCUTCHEON (14) onto VALVE (9) and secure to sink/deck surface

Series	A
32	2-7/16"
33	2-1/2"
34	2-7/16"
35	2-1/2"
36	2-1/2"
68	2-7/16"

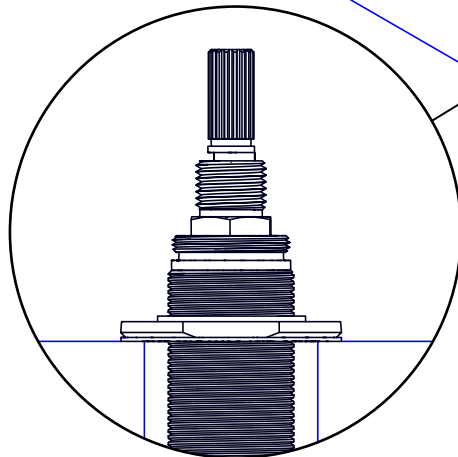
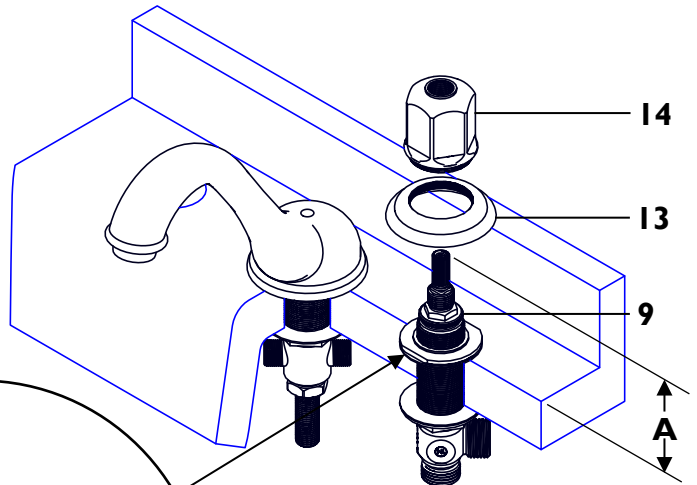
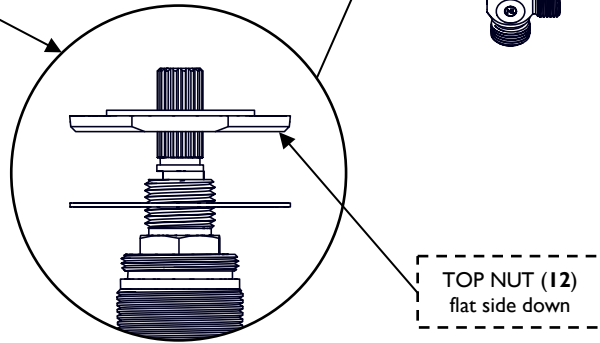
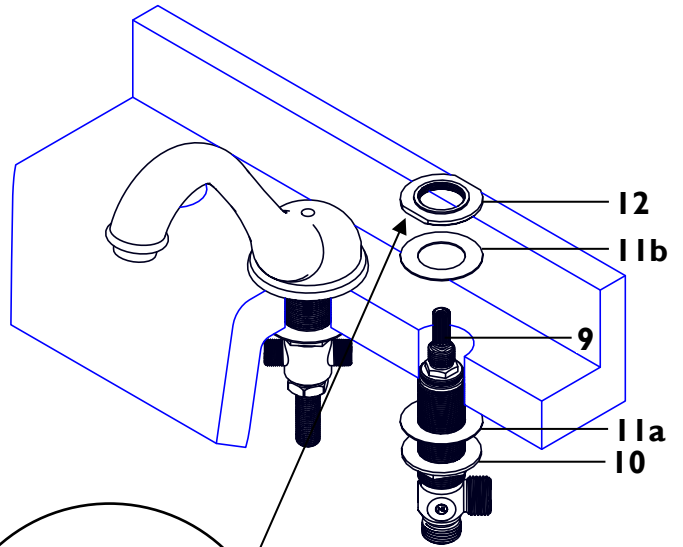

### 3 INSTALLING HANDLES

- Loosen SETSCREW (15b) from HANDLE (15a)
- Slide HANDLE (15) down onto and engage valve STEM (9a)
- Allow a minimum gap (1/32") between HANDLE (15) and ESCUTCHEON (14), tighten SETSCREW (15b)

**IMPORTANT:** To obtain proper alignment it may be necessary to rotate VALVE (9) so that HANDLE (15) is aligned to desired orientation

- Attach small hose NUT (16a) to spout TEE (5a)
- Attach large hose NUT (16b) to valve side OUTLET (9b)
- Repeat on other side valve

**NOTE:**  
INSTALL WASHER  
UNDER HANDLE(S)  
TO ACHIEVE PROPER  
GAP BETWEEN  
HANDLE AND  
ESCUTCHEON

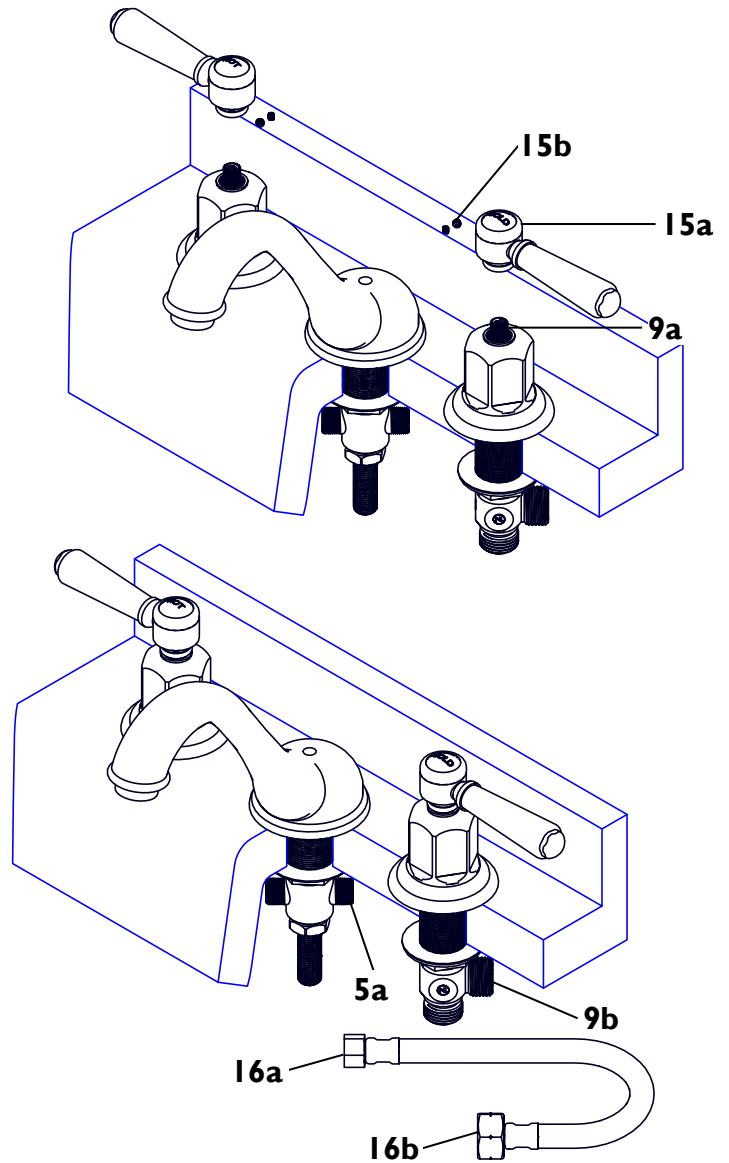
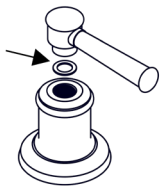

### 4 INSTALLING SUPPLY LINES

**IMPORTANT:** Prior to attachment, flush supply lines to remove debris that may cause damage or malfunction to valve cartridge.

The following are two types of supply lines (not included) that may be installed to the valve bodies:

#### Bullnose riser for exposed application

- Install BULLNOSE RISER (17a) using valve NUT (9c) to secure riser to valve INLET (9b)

-OR-

#### Flexible riser for non-exposed application

- Discard valve NUT (9c) & install FLEX RISER (17b) to valve INLET (9b)

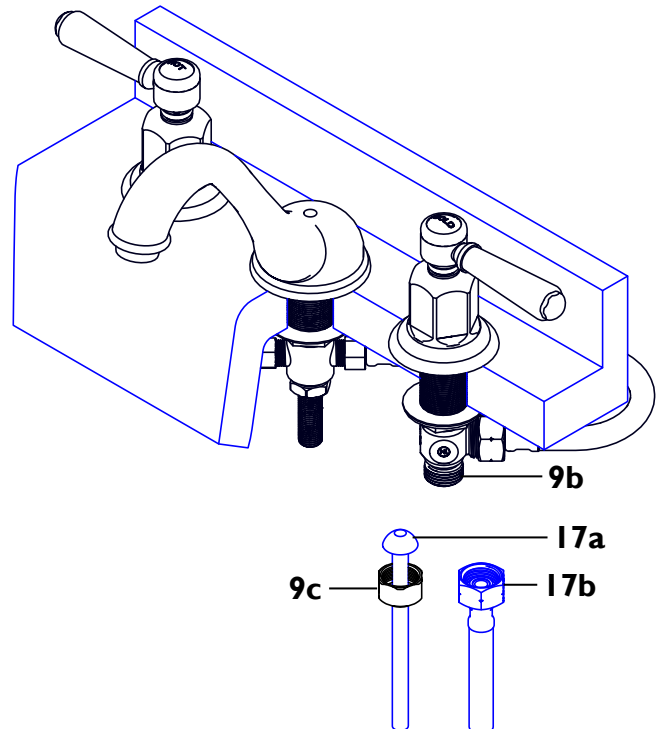

## 5 INSTALLING DRAIN

- Remove COLLAR (18) from assembly & apply silicone caulk (or equivalent) to underside of COLLAR (18)
- Insert BODY (19) from below & attach COLLAR (18)
- Align BALL ROD HOLE (19a) to rear & secure FLANGE NUT (20), FRICTION WASHER (21) & MACK WASHER (22) to sink drain hole
- Remove TAILPIECE (23) from BODY (19), apply thread sealant to threads & tighten into BODY (19)
- Insert STOPPER (24) into COLLAR (18) and rotate off-set HOOK (24a) to front to accept BALL ROD (25)
- Remove spring CLIP (26) from BALL ROD (25)
- Place CONE WASHERS (27) on both sides of rod BALL (28) with NUT (29) to backside
- Insert BALL ROD (25) into BALL ROD HOLE (19a) and through off-set HOOK (24a)

**IMPORTANT:** HOOK (24a) must be toward front of sink as shown to achieve proper stopper height

- Tighten NUT (29), but allow BALL ROD (25) to freely move up and down
- Insert LIFT ROD (31) through hole in spout from above
- Place STRAP (30) onto LIFT ROD (31) and tighten THUMB-SCREW (32)
- Place one end of CLIP (26) onto BALL ROD (25), then STRAP (30), gently squeeze CLIP (26) and slide other end of CLIP (26) onto BALL ROD (25)
- Check proper operation of STOPPER (24) and adjust by sliding STRAP (30) on LIFT ROD (31) as necessary

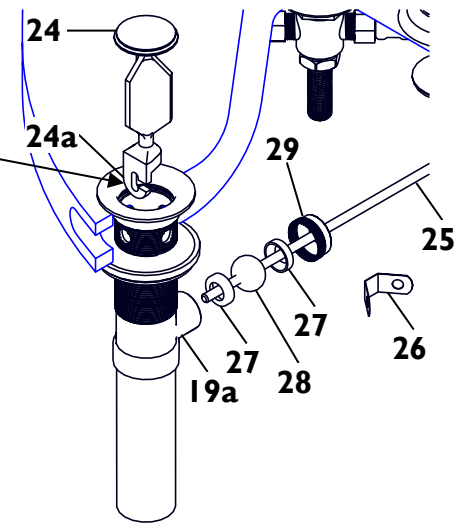
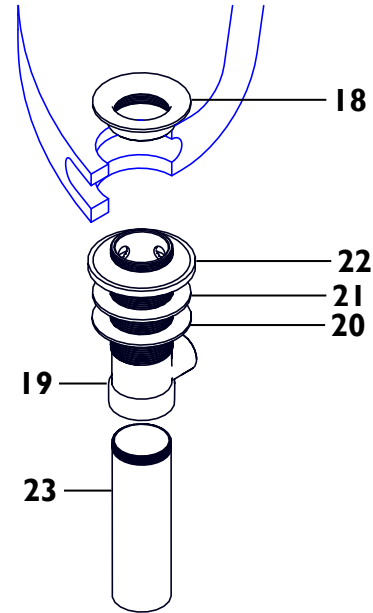

### Final connections

- Attach drain tailpiece to p-trap (not supplied)
- Turn on water supply valves and check for leak

